

Operation & Installation Manual



Model 8312 SmartStep™ Hot-Switching High Power Attenuator Units

This documentation may not be reproduced in any form, for any purpose unless authorized in writing by MCE / Weinschel Corporation.



© MCE / Weinschel Corporation
Frederick, Maryland
2002

TABLE OF CONTENTS

1. GENERAL INFORMATION.....	4
1-1. PURPOSE	4
1-2. SCOPE	4
1-3. EQUIPMENT DESCRIPTION	4
1-4. USING THE 8312 (MODEL NUMBER INDEX)	4
1-5. UNPACKING AND INSPECTION	5
1-6. RESHIPMENT INSTRUCTIONS	5
1-7. STORAGE INSTRUCTIONS	5
1-8. RELATED MANUALS	6
1-9. ELECTROSTATIC DISCHARGE SENSITIVE (ESD).....	6
1-10. ABBREVIATIONS & ACRONYMS	6
1-11. SAFETY CONSIDERATIONS.....	6
1-12. POWER REQUIREMENTS	6
1-13. ENVIRONMENTAL REQUIREMENTS	6
2. SPECIFICATIONS	7
2-1. GENERAL SPECIFICATIONS	7
2-2. PHYSICAL DIMENSIONS	8
3. INSTALLATION	9
3-1. RACKMOUNTING	9
3-2. INTIAL SETUP	9
3-3. INPUT/OUTPUT OPTIONS.....	9
3-3.1. POWER ENTRY MODULE ASSEMBLY	10
3-3.2. RF IN/RF OUT CONNECTORS.....	10
4. FRONT PANEL CONTROLS & INDICATORS	11
5. REMOTE OPERATION	12
5.1. IEEE-488 INTERFACE BUS CONNECTOR.....	12
5-2. GPIB ADDRESS/SERIAL COMMUNICATIONS SETTINGS.....	12-13
5-3. IEEE-488 (GPIB) BUS OPERATION	14
5-4. SERIAL OPERATION	15
5-4.1. RS-232 OPERATION	16
5-4.2. RS-422/485 OPERATION	17
5-5. STATUS REPORTING.....	18-19
5-6. GENERAL SYNTAX STRUCTURE	19
5-6.1. SYNTAX OF QUERIES.....	19
5-6.2. SYNTAX OF COMMANDS	19-20
5-6.3. OUTPUT DATA FORMAT.....	20
5-6.4. NOTATIONAL CONVENTION	20
5-7. 488.2 COMMON COMMANDS	21-22
5-8. GENERAL COMMANDS	23-24

6. MAINTENANCE.....	25
6-1. INSPECTION.....	25
6.2. PREVENTIVE MAINTENANCE.....	25
6.3. SPECIAL CLEANING INSTRUCTIONS	25
6-3.1. MICROWAVE COAXIAL CABLE ASSEMBLIES	25
6-3.2. CIRCUIT CARDS AND MODULES	25
6-3.3. MACHINED SURFACES AND HARDWARE	26
6-3.4. CHASIS CLEANING.....	26
6-3.5. CONNECTOR CLEANING.....	26
6.4. LINE VOLTAGE FUSE REPLACEMENT	27
7. REPLACABLE PARTS LIST.....	28
7-1. UNDERSTANDING REFERENCE DESIGNATORS	28
7-2. ORDERING INFORMATION.....	28
7-3. DRAWING NUMBER.....	28
7-4. REPLACABLE PARTS LIST.....	28
7-4.1. REFERENCE DESIGNATOR	28
7-4.2. DESCRIPTION	28
7-4.3. PART NUMBER.....	28
7-4.4. VENDOR PART NUMBER	28
7-5.5. CAGE CODE	28
7-4.6. ASSEMBLY AND COMPPONET LOCATION	28
8312-15-F & -R, ATTENUATOR UNIT ASSEMBLY REPLACEABLE PARTS LIST (P/N 193-8067-1).....	29-30
8312-31-2-F & -R, ATTENUATOR UNIT ASSEMBLY REPLACEABLE PARTS LIST (P/N 193-8067-2).....	31-32
8. ACCESSORIES	33
9. CONTACTING MCE/WEINSCHEL.....	33
10. MCE / WEINSCHEL WARRANTY	34
11. ASSEMBLY/WIRING DIAGRAMS	
MODEL 8312-1-X ASSEMBLY DRAWING	193-8067
MODEL 8312 WIRING DIAGRAM	193-8069

1. GENERAL INFORMATION:

1-1 PURPOSE: This manual contains setup and operation information for the MCE/Weinschel's 8312 Series of *SmartStep*[™] Hot-Switching High Power Attenuator Units (193-8067-X). The manual also provides component location, reference designators, part numbers, and nomenclature to identify all the assemblies and sub-assemblies of the Hot-Switching High Power Attenuator Unit.

1-2 SCOPE: This manual is to be used in conjunction with the operation and maintenance of a 8312 Series *SmartStep*[™] Hot-Switching High Power Attenuator Unit. The manual also provides a description of each assembly; assembly parts list; block diagrams: and general maintenance procedures to maintain the instrument.

1-3 EQUIPMENT DESCRIPTION: MCE/Weinschel's 8312 Series *SmartStep* Hot-Switching High Power Attenuator Units represents a new concept in programmable attenuation for high power (up to 100 watts) bench test and subsystem applications. Standard Model 8312 designs are available in 0-15 dB or 0-31 dB configurations which can be via front panel controls or standard communications interfaces including GPIB (IEEE-488) and RS-232/RS-422/RS485. This series operates over the DC to 13.0 GHz frequency range and offers a power Handling up to 100 Watts average.



1-4 USING THE 8312: MCE/Weinschel's design approach uses a highly adaptable platform that allows configuration of the step attenuator to the customers requirements. When the controller requests a new attenuation level the input switch terminates the input signal into a 50 Ohm load. (Figure 1) This input switch is hot-switchable at 100 Watts of input power. This will remove the high power signal from the main signal path. With no signal connected to the attenuator path the controller then commands the series of relays to configure the attenuator for the requested attenuation value. Then the input switch re-connects the input signal to the attenuator path. The system can be operated with either a remote controller (IEEE-488 or RS-232) or through front panel control.

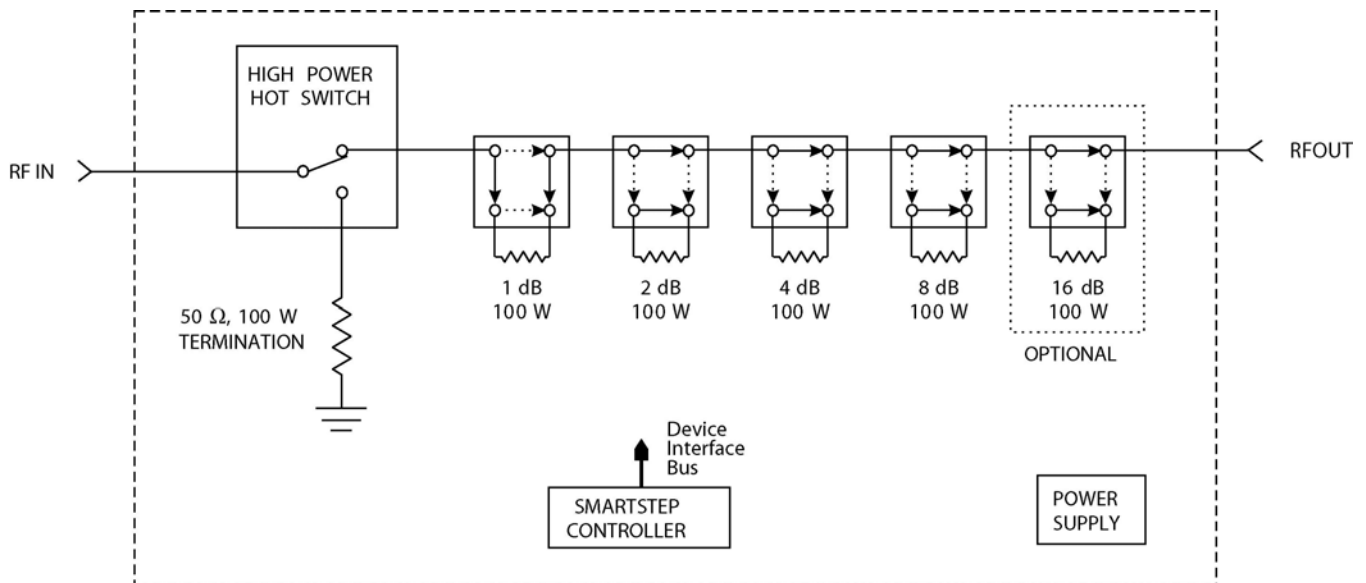
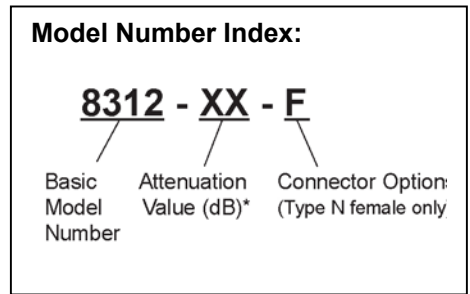

Figure 1. 8312 Block Diagram

1-5. UNPACKING AND INSPECTION: Upon unpacking the equipment, retain the shipping container and packing material for future shipment for recalibration. Perform the following initial inspection:

- a. Carefully look at the outside of the shipping container for discoloration, stains, charring, or other signs of exposure to excessive heat, moisture, or liquid chemicals. Check for any physical damage to the shipping container such as dents, snags, rips, crushed sections or areas, or similar signs of excessive shock or careless handling.
- b. With the equipment and any accessory package removed from the shipping container, check each item against the packing list or Items Supplied List. If any items are missing, contact the Weinschel Corporation Customer Service Department.
- c. Carefully inspect the equipment looking for dents, deep scratches, damaged or loose connector, or any other
- d. signs of physical abuse or careless handling. If damage is found, forward an immediate request to the delivering carrier to perform an inspection and prepare a concealed-damage report. DO NOT destroy any packing material until it has been examined by an agent of the carrier. Concurrently, report the nature and extent of damage to Weinschel Corporation, giving equipment model and serial numbers, so that necessary action can be taken. Under U.S. shipping regulations, damage claims must be collected by the consignee; DO NOT return the equipment to MCE/Weinschel Corporation until a claim for damages has been established.

1-6. RESHIPMENT: Use the best packaging materials available to protect the unit during storage or reshipment. When possible, use the original packing container and cushioning material. If the original packing materials are not available, use the following procedure:

- a. Wrap the storage cases in sturdy paper or plastic;
- b. Place the wrapped storage cases in a strong shipping container and place a layer of shock-absorbing material (3/4 inch minimum thickness) around all sides of the unit to provide a firm cushion and to prevent movement inside the container.
- c. If shipping the unit for service, attach a tag to indicate:
 1. model and serial numbers
 2. service required
 3. description of malfunction
 4. return address
 5. authorization to conduct repairs
 6. return authorization number
- d. Thoroughly seal the shipping container and mark it FRAGILE. Ship to:

MCE/Weinschel Corporation

Attn: Customer Service Department
 5305 Spectrum Drive
 Frederick, MD 21703-7362
 or to an authorized sales representative.

1-7. STORAGE: Storage of the Model 8312 Series *SmartStep*TM Hot-Switching High Power Attenuator Unit is possible for extended periods without incurring damage to internal circuitry if the 8312 Series is packaged according to the instructions above. The safe limits for storage environment are as follows:

Temperature: 67° to +167 °F (-55° to +75 °C)
Humidity: less than 95% without condensation
Altitude: Up to 40,000 feet



1-8. RELATED MANUALS: The following manuals contain information that may be used in conjunction with this manual to operate, service, or calibrate this instrument.

<u>Manual</u>	<u>Title</u>
H4-1 and H4-2	Federal Supply Code for Manufacturers Cataloging Handbook

1-9. ELECTROSTATIC DISCHARGE SENSITIVE: The equipment documented in this manual contains certain Electrostatic Discharge Sensitive (ESDS) components or parts. Therefore, certain procedures/steps are identified by the use of the symbol . This symbol is used in two ways:



All procedures and/or steps identified as must be followed exactly as written and according to accepted ESDS device handling procedures. Failure to comply **WILL RESULT** in ESDS damage.

- a. When the ESDS symbol is placed between a paragraph number and title  all of that paragraph, including all subparagraphs, is considered ESDS device handling procedure.
- b. When the ESDS symbol is placed between a procedure/step number and the text , all of that procedure is considered an ESDS device handling procedure.

1-10. ABBREVIATIONS AND ACRONYMS: The following list contains abbreviations used throughout this manual. Abbreviations and acronyms that are not listed conform to MIL-STD-12D.

DUT	Device Under Test
ESDS	Electrostatic Discharge Sensitive
DIB	Device Interface Bus
TBD	To Be Determined

1-11. SAFETY CONSIDERATIONS: The Hot-Switching High Power Attenuator Unit and all related documentation must be reviewed for familiarization with safety markings and procedures before any operation and/or service. Refer to the SAFETY SUMMARY located at the beginning of this manual for a summary of safety information and procedures. Following these simple safety precautions will ensure safe operation and service of the Hot-Switching High Power Attenuator Unit.

1-12. POWER REQUIREMENTS: MCE / Weinschel supplies a detachable power cable (P/N 068-21) to connect an 100 to 240 Vac power source with a frequency between 50 to 60 Hz to the Hot-Switching High Power Attenuator Unit. To minimize shock hazard, the instrument chassis must be connected to an electrical ground. Using the supplied three-conductor power cable ensures that the instrument can be firmly connected to the ac power source and electrical ground (safety ground) at a grounded power outlet. Refer to paragraph 4-2 (Initial Setup) before applying any power to the instrument.

1-13. ENVIRONMENTAL REQUIREMENTS: This instrument performs best within its specifications when operated within a controlled environment having an ambient temperature of $0^{\circ}\pm 50^{\circ}\text{C}$, Relative Humidity of up to 95% non condensing, and a altitude of less than 40,000 feet. Operating beyond these limits can affect the accuracy and performance of the instrument and damage internal circuitry.

2. SPECIFICATIONS:

2-1. GENERAL SPECIFICATIONS:

Input Power Requirements	ac 100 to 240 Vac, 50/60 Hz, 50 Watts		
Environmental	Operating Temperature	0 to +50°C	
	Storage Temperature:	67° to +167 °F (-55° to +75°C)	
	Humidity:	96%	
	Altitude:	40,000' (12,192M)	
IEEE-488 Bus ⁽¹⁾	Connector:	24-pin per IEEE-488.1	
	Protocols:	per IEEE-488.2	
	Indicators:	Remote (RMT), Listen (LSN), Talk (TLK), SRQ (SRQ)	
RS-232 Bus ⁽²⁾	Connector:	9-pin male D	
	Signals:	TXD, RXD, RTS, CTS, DTR, GND	
	Baud Rates:	2400, 9600, 19200, and 38400	
	Data Bits:	8	
	Handshaking:	None, RTS/CTS, XON/XOFF	
	Parity:	None, Odd, Even	
	Indicators:	Tx (Transmit) and Rx (Receive)	
RS-422 Bus ⁽³⁾	Connector:	9-pin male D	
	Signals:	TXD+, TDX-, RXD+, RTX-, RTS+, RTS-, CTS+, CTS-, and signal GND	
	Baud Rates:	2400, 9600, 19200, and 38400	
	Data Bits:	8	
	Handshaking:	None, RTS/CTS, XON/XOFF	
	Parity:	None, Odd, Even	
	Indicators:	Tx (Transmit) and Rx (Receive)	
RF Characteristics ⁽⁴⁾	Connectors:	Type N, Female	
	Frequency Range:	dc - 13 GHz	
	Impedance:	50 Ω	
	SWR:	50 MHz - 5 GHz:	1.60 (Maximum)
		5 GHz - 13 GHz:	1.95 (Typical)
	Attenuation Range:	15 dB/1 dB steps (8312-15-F)	
		31 dB/1 dB steps (8312-31-F)	
	RF Power Rating:	50 MHz - 5 GHz:	100 Watts (Maximum)
		5 GHz - 13 GHz:	50 Watts (Maximum)
	Attenuation Settings:	100, 000 selections (minimum)	
	Attenuation Update Rate:	1 second (Typical)	
	Incremental Accuracy:	<u>Frequency Range</u>	<u>1-15 dB</u> <u>16-31 dB</u>
		50 MHz - 3 GHz:	+0.5 dB +0.8 dB
		3 GHz - 5 GHz:	+0.5 dB +0.8 dB
		5 GHz - 13 GHz:	+2.0 dB +3.0 dB
	Insertion Loss (dB):	<u>Frequency Range</u>	<u>8312-15-F</u> <u>8312-31-F</u>
		50 MHz - 3 GHz:	3.0 3.5
		3 GHz - 5 GHz:	4.0 4.5
		5 GHz - 13 GHz:	7.0 8.0

NOTES:

1. GPIB/IEEE-488 model allows user-selectable addresses.
2. RS-232 can be used with standard PC serial port for short and medium distances (up to approximately 50 ft).
3. RS-422: designed for very long distance communications (4000 ft) and optimized as a single node protocol, typically with one device connected to a single port.
4. Refer to Individual data sheet (Appendix C) for detailed specifications on internal attenuators.

2-2. PHYSICAL DIMENSIONS:

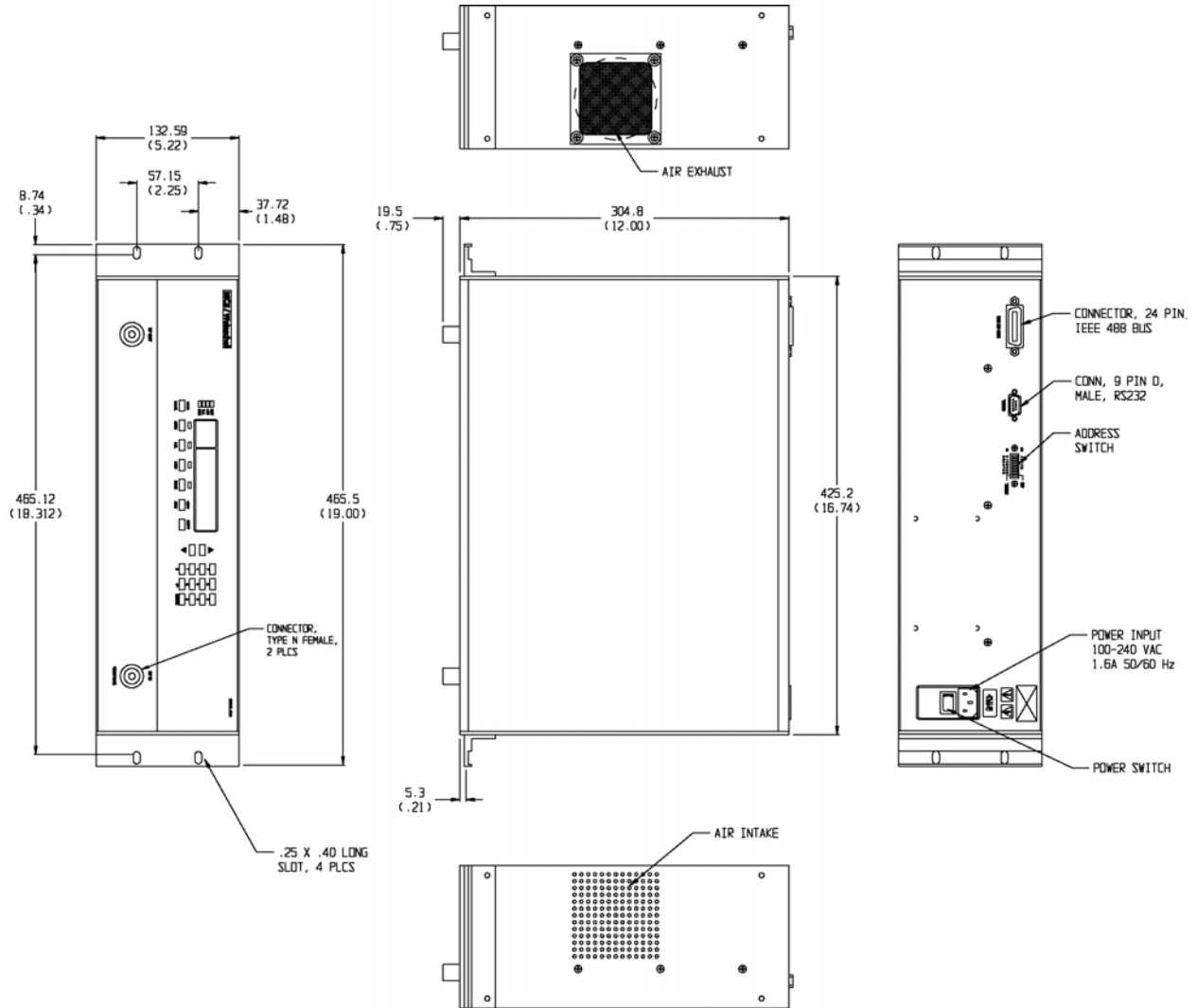

NOTE: All dimensions are given in mm (inches) and are maximum, unless otherwise

3. INSTALLATION:

3-1. RACKMOUNTING: Standard 8312 Hot-Switching High Power Attenuator Units are shipped with four plastic feet mounted to the bottom cover, this allows the user to place the instrument on any bench or to stack the with other Weinschel instruments. The Model 8312 can also be rack mounted using Rack Mounting Kit (P/N 193-TBD). This kit will allow the Model 8312 to be mounted in any rack or cabinet that is designed according to EIA RS-310 or MIL-STD-189.

3-2. INITIAL SETUP: The following initial setup procedures should be performed prior to operating the Hot-Switching High Power Attenuator Unit.

- a. Perform inspection paragraph 1-5 prior to connecting the 8312 Series to any power source.
- b. Check that the external power source outputs to the 8312 Series are in accordance with Section 2, Specifications.
- c. Install the 8312 Series into a cabinet or rack, if desired.
- d. Using the supplied power cord connect the 8312 Series to the external power source.
- e. Setup the IEEE-488 bus address or RS-232/422 Communications options for your application using 5. If using the RS-422 serial configure the selectable signal pair terminations using paragraph 5-3.

3-3 INPUT/OUTPUT OPTIONS: The following paragraphs provide a description of the connections that can be made to the 8312 Series Hot-Switching High Power Attenuator Unit. Figure 2 shows the location of these connectors and switches.



Sufficient power levels are present at the Power Input Assembly to cause personal injury. Ensure that the instrument power cord is DISCONNECTED before attempting to change fuses.

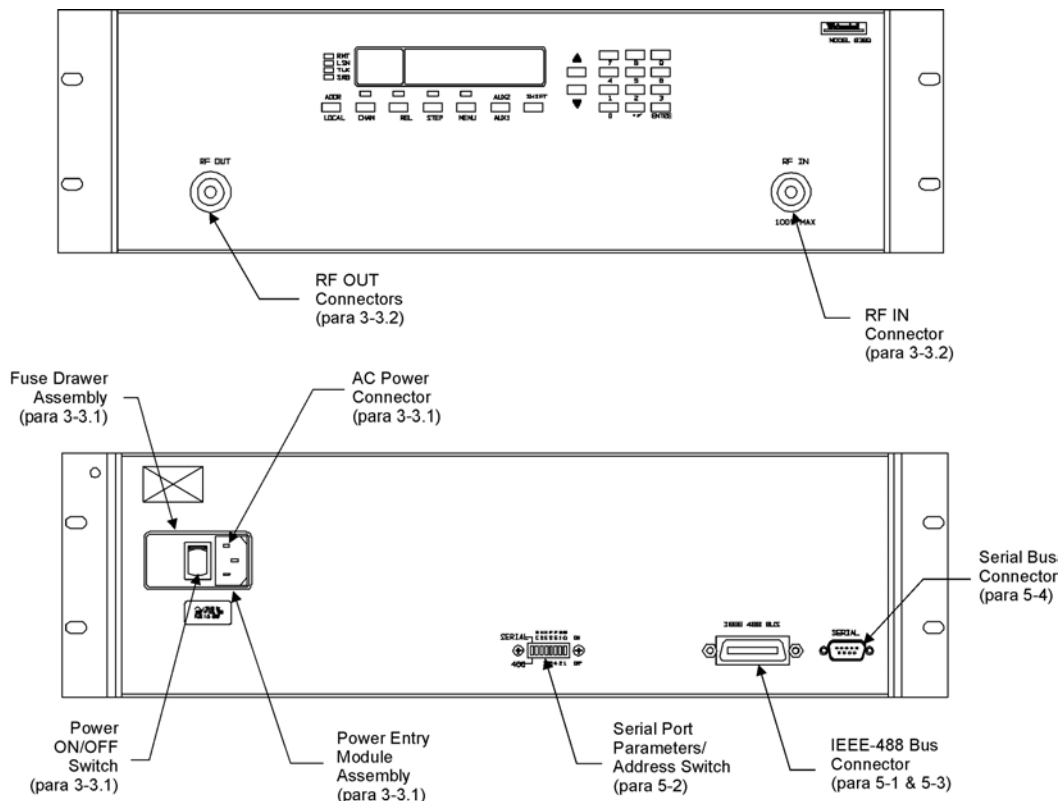

Figure 2. Front & Rear Panel Connectors

3-3.1 POWER ENTRY MODULE ASSEMBLY: The Power Entry Module Assembly located on the rear panel contains a three-prong ac power input connector and a fuse drawer assembly (Figure 1). The **Fuse Drawer Assembly** contains the line voltage fuse (Weinschel P/N 052-1-1.5). The Model 8312 uses a T 1.5A, 250 Vac fuse which is 5 x 20 mm in size. Refer to paragraph 6-4 for replacement of the fuse.

The **AC Power Connector**, located on the left side of XF1 (Figure 2), is a plug-type, prong insert connector with three conductors for connection of the power cord (P/N 068-21) to the Power Supply Assembly located within the Hot-Switching High Power Attenuator Unit. This connector also grounds the chassis of the Hot-Switching High Power Attenuator Unit when the ac power cord is connected to a grounded wall outlet. If necessary, use a three prong to two prong adapter and connect the adapter's ground lead to the outlet plate retaining screw.

The **Power ON/OFF Switch** is located on the rear panel and in part of the Power Entry Module Assembly. Placing the POWER ON/OFF switch in the ON position applies power to the instrument.



When applying an RF signal to the RF INPUT connector, DO NOT exceed the maximum allowable power level specifications of the Model 8312.

3-3.2. RF IN/RF OUT CONNECTORS: A typical 8312 Series Hot-Switching High Power Attenuator Unit is supplied with two Type N female connectors that are mounted on the front panel. These connectors provide input and output ports where various types of RF signals (dc to 13 GHz, up to 100 W) can be applied to the devices internally mounted in the Model 8312.

4. FRONT PANEL CONTROLS & INDICATORS:

The following paragraphs provide setup and general guidelines for operating the 8312 Series **SmartStep** Hot-Switching High Power Attenuator Unit and its different bus configurations. Also provided is a general description of the internal circuitry of the 8312.

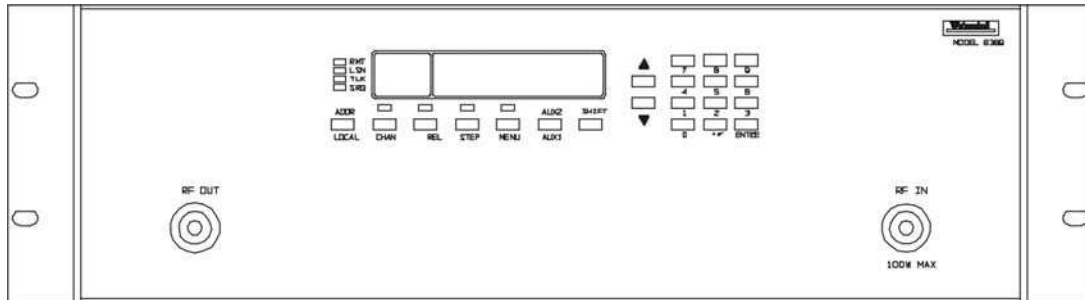

Figure 3. 8312 Series Front Panel

ENTRY keys: The numeric entry keys allow the user to directly enter numeric values. When using the keypad, values are not updated until the ENT (enter) key is pressed. The Minus (-) and CE (clear entry) functions may be accessed via first depressing the SHIFT key.

INCR & DECR : The INCR and DECR keys allow settings to be scrolled from their current value. Unlike the ENTRY keys, the new setting is updated immediately without the use of the ENT key.

CHAN: Allows the selection of the current channel, as indicated by the CH1-CH4 indicators. Repeated depressions of the CHAN key will select the next available channel. The main display will show the current setting of the channel.

REL: This key control allows the use of a relative mode for attenuators, as indicated by the REL mode indicator. When turned on, the currently displayed attenuation value is used as a reference value from which the attenuation may be set. In this mode, attenuation values may be positive or negative from the reference setting. When REL is turned off, the display returns to the actual attenuation setting for the channel.

STEP: This key allows the user to change the attenuation step size used by the INCR and DECR keys. When turned on, as, indicated by the STEP indicator, the current step size is displayed in the main display, and a new value may be entered using the INCR/DECR or ENTRY keys. The step size may be set to any multiple of the intrinsic step size for the currently selected channel.

MENU: Invokes the menu functions. Menu selections may be made via the INCR and DECR keys. (NOTE: menu functions are currently not implemented as of 3/8/99)

AUX1/AUX2: The function of these keys is user-programmable via remote operation. They invoke any currently defined AUX1 and AUX2 macros. Refer to the macro programming section for information on creating macro definitions.

LOCAL: This key places the 8312 in local operation mode, unless the key function has been overridden via an IEEE-488.2 local lockout or execution of the LOCKOUT command.

ADDR: This key displays the current IEEE-488.2 address. The address may be changed from the front-panel, however, the initial setting at power on is derived from the rear-panel address switch.

5. REMOTE OPERATION:

The following paragraphs provide setup and general guidelines for operating the Model 8312 using an external controller.

5-1. IEEE-488 INTERFACE BUS CONNECTOR: Joining the Model 8312-1 to a system controller requires the connection of IEEE-488 control bus cable to the IEEE-488 INTERFACE BUS connector located on the rear panel. Figure 3 shows the connector's contact pin numbering scheme and lists the signal designator for signal present at each contact pin.

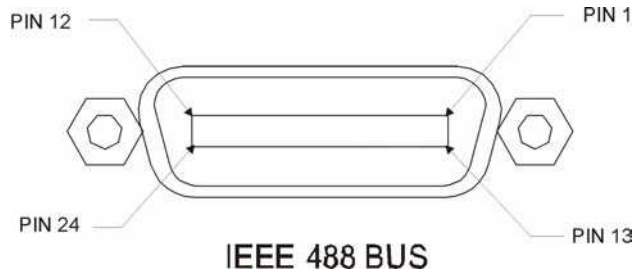

PIN No.	SIGNAL LINE	PIN No.	SIGNAL LINE
1	DIO 1	13	DIO 5
2	DIO 2	14	DIO 6
3	DIO 3	15	DIO 7
4	DIO 4	16	DIO 8
5	EOI (24)**	17	REN (24)**
6	DAV	18	GND (6)*
7	NRFD	19	GND (7)*
8	NDAC	20	GND (8)*
9	IFC	21	GND (9)*
10	SRQ	22	GND (10)*
11	ATN	23	GND (11)*
12	SHIELD	24	GND, LOGIC
* GND (N) refer to the signal ground return of the referenced pin. ** Return pin on pin 24.			

Figure 3. IEEE-488 Interface Bus Pin Locations

5-2. GPIB ADDRESS/SERIAL COMMUNICATIONS SETTINGS: The GPIB Bus Address and Serial Communications options are programmed via an internal 8 position DIP switch SW1 which is located on the rear panel. The switch is shared between the two functions, with SW1-1 controlling the selection. When SW1-1 is OFF, the remaining switches set the GPIB bus address. Likewise, when SW1-1 is ON, the switches are used to select the various serial options, including baud rate, parity, and handshaking. Refer to Figure 4 for switch location.

To configure the IEEE-488 bus address or serial communications parameters, select the appropriate switch setting using the tables located in below (Figure 4).



Note: All switches are shown in the OFF position.

GPIB	SW1	Serial	Serial Parameters															
SP	1	SP	Mode Select On = Serial parameters Off = GPIB address															
---	2	Echo	Echo Echo Enable On = Echo received data Off = No echo															
---	3	HndshkSel	Handshaking Select On = RTS/CTS Off = XON/XOFF															
A4 (16)	4	HndshkEna	Handshake Enable On = Enabled Off = Disabled															
A3 (8)	5	ParitySel	Parity Select On = Odd Off = Even															
A2 (4)	6	ParityEna	Parity Enable On = Enabled Off = Disabled															
A1 (2) A0 (1)	7 8	BR1 BR2	BaudRate Select (see below) BaudRate Select <table border="1" style="margin-left: 20px;"> <thead> <tr> <th>BR1</th> <th>BR0</th> <th>RATE</th> </tr> </thead> <tbody> <tr> <td>0</td> <td>0</td> <td>2400</td> </tr> <tr> <td>0</td> <td>1</td> <td>9600</td> </tr> <tr> <td>1</td> <td>0</td> <td>19200</td> </tr> <tr> <td>1</td> <td>1</td> <td>38400</td> </tr> </tbody> </table>	BR1	BR0	RATE	0	0	2400	0	1	9600	1	0	19200	1	1	38400
BR1	BR0	RATE																
0	0	2400																
0	1	9600																
1	0	19200																
1	1	38400																

Note: The GPIB Bus address is selectable from 0 to 30 via the rear panel dip switch. This switch is factory set to 10.

IEEE-488 Address Truth Table

Switch Number	4	5	6	7	8
Decimal Weight	16	8	4	2	1
Address:					
0	0	0	0	0	0
1	0	0	0	0	1
2	0	0	0	1	0
3	0	0	0	1	1
4	0	0	1	0	0
5	0	0	1	0	1
6	0	0	1	1	0
7	0	0	1	1	1
8	0	1	0	0	0
9	0	1	0	0	1
10	0	1	0	1	0
20	1	0	1	0	0
30	1	1	1	1	0

Figure 4. Internal Dip Switch

5-3. IEEE-488 (GPIB) Bus Operation

The internal functions of Model 8312 are controlled via an IEEE-488 bus and an external controller. The front panel LSN and RMT indicators (Figure 2) are used as status indicators for the Model 8312 *SmartStep* Interface's IEEE-488 bus operation. During bus operation a flashing LSN indicates that the Model 8312 is receiving. The RMT indicator is illuminated when the Model 8312 is in the remote state.

The table below summarizes the IEEE-488.1 interface functions that are implemented by the Model 8312.

Interface Function	Subset	Description
Source Handshake	SH1	Fully implemented
Acceptor Handshake	AH1	Fully implemented
Talker	T6	All basic Talker functions No extended addressing
Listener	L4	All basic Listener functions. No extended addressing
Service Request	SR1	Fully implemented
Remote/Local	RL1	Fully implemented
Parallel Poll	PP0	No Parallel Poll Capability
Device Clear	DC1	Fully implemented
Device Trigger	DT0	No Trigger
Controller	C0	No Controller Functions
Electrical Interface	E2	All tri-state drivers

The GPIB interface of the 8312 is IEEE-488.2 compliant. The 8312 recognizes instructions and data sent via the GPIB interface in the form of program messages comprised of ASCII characters. A program message is comprised of a sequence of program message units separated by semicolons and terminated by a line terminator (LINE END). A line terminator takes the form of an ASCII LF character (0AH), or an EOI signal asserted with the last data byte, or both. The 8312 program message units may be divided into two syntax groups: commands and queries. Refer to the section on command syntax for more information.

5-4. Serial Operation: The serial interface (RS232/RS422) provides a means of remotely programming the 8312 via external computer. The 8312 provides for user-selectable communications parameters via a DIP switch (SW1), including baud rate, data format, and handshaking method. LED indicators are provided for transmit (TX) and receive (RX) activity. Selection between RS232/RS422 mode is controlled via an internal 4 position DIP switch SW2, which also provides for user-selectable 120 ohm terminations for the RS422 receiver lines. The RS422 mode transceivers are electrically compatible with RS485.

SW2	RS232	RS422 RS485	Description
1	OFF	User Select	CTS Termination On = Termination Off = No Termination
2	OFF	User Select	RXD Termination On = Termination Off = No Termination
3	OFF	ON	RI/RTS Select
4	ON	OFF	Serial Mode On = RS232 Off = RS422

The data format includes a start bit, eight data bits, and one stop bit (N81). The Baud Rate may be set to 2400, 9600, 19200, or 34800. Parity selections include settings for None, Even, or Odd parity. Handshaking may be enabled, if desired, and the method may be set to either hardware (RTS/CTS) or software (XON/XOFF). For interactive terminal use, echoing may be enabled, in which the 8210A will echo all characters received back to the terminal.

All data and commands are encoded using the ASCII character set. The syntax for commands is the same as for GPIB operation, and uses the syntax structure defined by IEEE 488.2, with the exception of the command termination rules. Commands sent to the 8312 may be terminated with either an ASCII CR (0x0D) or ASCII LF (0x0A) character. By default, all responses from the 8312 are terminated in an ASCII CR/LF sequence (0x0D followed by 0x0A).

Software handshaking uses the XON/XOFF scheme in which an ASCII DC3 (0x13) character is transmitted by the receiver to indicate that data transmission should be halted (XOFF), and an ASCII DC1 (0x11) character is transmitted to indicate that data transmission may continue (XON). Hardware handshaking utilizes the RTS and CTS lines. When the RTS output signal is asserted true, the unit is ready for data. This signal should be connected to the external computer's CTS input signal, so that when the receiver is ready, the transmitter may send data. When the unit is not ready for data, it unasserts the RTS signal, halting data transmission. Likewise, the unit monitors the CTS input signal during data transmission, halting transmission if the external computer unasserts its RTS signal. In addition, the 8312 unasserts the RTS signal while command execution is in progress.

For those systems incorporating local front panel controls, the serial port can lockout local users, providing a Remote/Local function similar to that of GPIB operation.

5-4.1. RS-232 Operation: The RS-232 Serial port is a 9-pin connector that is compatible with the pin-out of the serial port on a PC. It allows the use of a null-modem style cable. The pin-out for the connector is show below. For clarity, the signal names and directions are relative to the 8312.

<u>Pin</u>	<u>Signal Name</u>	<u>Description</u>	<u>Direction</u>
1	DCD	unused	---
2	RxD	Receive data	input
3	TxD	Transmit data	output
4	DTR	Signals DTE is on-line	output
5	GND	Ground	---
6	DSR	unused	---
7	RTS	Signals DTE is ready	output
8	CTS	Signals DCE is ready	input
9	RI	unused	---

The DTR signal is asserted when power is on, indicating that the unit is ready.

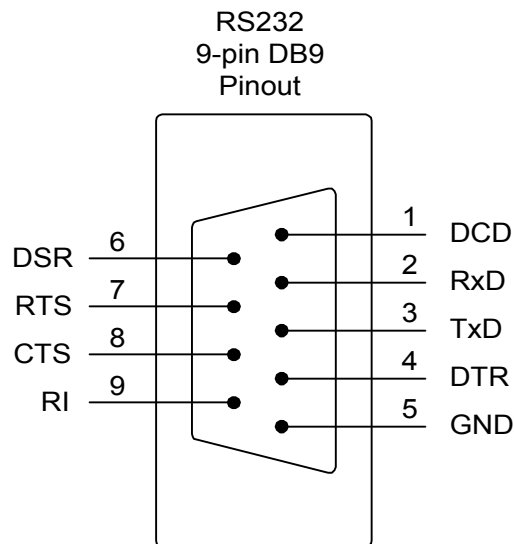

Null Modem Cable

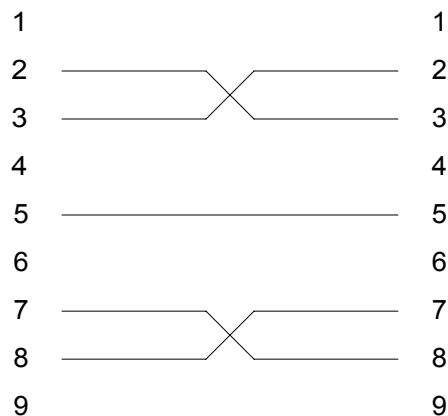

5-4.2. RS-422/485 Operation: The RS-422/RS-485 Serial mode is useful in applications requiring long cable lengths (up to 5000 ft at 9600 baud), or in electrically noisy environments. All communication parameters available for the RS232 port are also available under RS-422 operation (baud rate, handshaking, etc). Full Duplex operation is supported. The RS-422 port utilizes a 9-pin connector. The pin-out for the connector is show below. For clarity, the signal names and directions are relative to the 8312.

<u>Pin</u>	<u>Signal Name</u>	<u>Description</u>	<u>Direction</u>
1	RxD+	Receive data	input
2	RxD-	Receive data	input
3	TxD-	Transmit data	output
4	TxD+	Transmit data	output
5	GND	Ground	---
6	CTS+	Clear To Send	input
7	RTS-	Request To Send	output
8	CTS-	Clear To Send	input
9	RTS+	Request To Send	output

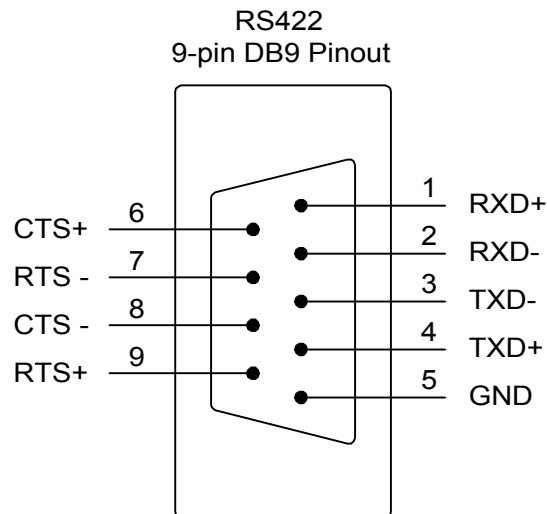

5-5. Status Reporting

The 8312A implements the 488.2 Status Reporting Structure, which utilizes the IEEE488.1 status byte with additional data structures and rules. The Status Byte Register can be read with either a serial poll (IEEE-488 operation only) or the *STB? common query command. The Service Request Enable Register (SRE) allows the user to select which bits in the Status Byte Register may cause service requests. A bit value of one indicates that the corresponding event is enabled, while a bit value of zero disables an event. The Service Request Enable Register may be accessed with the *SRE and *SRE? common commands. The Status Byte Register may be cleared with the *CLS common command, with the exception of the MAV bit, which is controlled by the operation of the Output Queue. The SRE Register is set to 0 at power-on, disabling all events.

Status Byte Register/ Service Request Enable Register Formats

D7	D6	D5	D4	D3	D2	D1	D0
	RQS	ESB	MAV		EEQ		

Bit	Mnemonic	Description
6	RQS	Request Service: This bit, if set, indicates that the device is asserting the SRQ signal.
5	ESB	Event Status Bit: This bit is true when an enabled event in the Event Status Register is true.
4	MAV	Message Available: This bit is true when there is valid data available in the output queue.
2	EEQ	Error/Event Queue: This bit is true when there is Error/Event data available in the Error/Event queue.

The Standard Event Status Register is used to report various IEEE 488.2-defined events. The register contents may be accessed with the *ESR? command. An Event Status Enable Register allows the user to select which bits in the ESR that will be reflected in the ESB summary message bit of the Status Byte Register. The Event Status Enable Register may be accessed with the *ESE and *ESE? common commands. The Event Status Register is cleared by an *ESR? query or *CLS common command. The ESE Register is set to 0 at power-on, disabling all events.

Standard Event Status Register/ Standard Event Status Enable Register Formats

D7	D6	D5	D4	D3	D2	D1	D0
ON	URQ	CME	EXE	DDE	QYE	RQC	OPC

Bit	Mnemonic	Description
7	PON	Power On: This bit indicates that the device has powered-on
6	URQ	User Request: This event bit indicates that a local control is causing a User Request
5	CME	Command Error: The parser has detected a syntax error in the current command.
4	EXE	Execution Error: The command could not be properly executed due to an illegal input range or other inconsistent data.
3	DDE	Device Dependent Error: A command could not properly complete due to some device specific error
2	QYE	Query Error: This bit indicates that either an attempt has been made to read data when there was none present, or that data in the Output Queue has been lost
1	RQC	Request Control: The device is requesting control (not implemented)
0	OPC	Operation Complete: This bit is generated in response to an *OPC command. It indicates that the ITS 2000 has completed all pending operations.

The Status Reporting Registers may be used for serial communications, with certain limitations. The Status Byte Register can only be read via the *STB? query command, as the comm port does not provide for a serial poll operation. Also, as data in the Output Queue is sent automatically during serial operation, the MAV message available bit in the STB serves no purpose.

5-6. GENERAL SYNTAX STRUCTURE: The following paragraphs outline the general syntax and command structure for the Model 8312. This structure is common to all bus flavors of the Model 8312.

NOTE

In the descriptions that follow, the term whitespace is used to define a sequence of one or more combinations of ASCII Space (20h), Carriage return (0Dh), or Tab (09h) characters.

5-6.1 SYNTAX OF QUERIES: A query message unit is made up of a query header ending in an ASCII question mark character '?' (3FH), followed by optional whitespace, and ended by a program message terminator. To form a multiple query, separate the individual program message units with a semicolon.

Examples : "ATTN?"
"ASSIGN?"

b. Multiple Query Commands:

"ATTN?; ASSIGN?"

5-6.2 SYNTAX OF COMMANDS: A command message unit is made up of a command header, optionally followed by an argument and units, and ended by a program message terminator. If multiple commands are made on the same program line, separate the individual command messages with a semicolon.

Arguments - The 8312 supports a variety of argument types that can be used in program commands. These types are:

- Character Program Data
- Integer Numeric Program Data
- Real Numeric Program Data

Each data type has its own rules of syntax. The following paragraphs provide the syntax rules for each of the argument types listed above.

Character Program Data-This data type is comprised of the set of printable ASCII characters (excluding those used as delimiters). Character program data represents alpha or alphanumeric strings. The use of alpha characters is case-insensitive. If the first character of the string is not an alpha character, then the string must be delimited with either the ASCII single-quote (') or double-quote (") character in order to distinguish the string from a numeric data type.

Examples: ATTN1
ON
"150T"

Integer Numeric Program Data-This data type is used to represent integer, binary, or hexadecimal numeric information, all of which may be used interchangeably. Integer data is comprised of the numeric digits '0'-'9', binary data is comprised of the digits '0' and '1' preceded by the characters '#B', and hexadecimal data is comprised of the digits '0'-'9', and the letters 'A'-'F', preceded by the characters '#H' or the C language style prefix '0x'.

Examples: 123 (integer)
#H55 (hex)
0xAA (hex)
#B1010 (binary)

Real Numeric Program Data-This data type includes decimal numbers containing a sign, decimal point, and/or an exponent. The format is as follows: [sign]digits[.[digits]][E[sign]digits]

Examples: 2
 2.5
 -35.25E+2

In the command descriptions that follow, argument types are also described using the following additional conventions to indicate the relative size of the parameter:

byte	- used to indicate an 8-bit unsigned integer
word	- used to indicate a 16-bit unsigned integer
int8	- 8-bit integer
int16	- 16-bit integer
int32	- 32-bit integer
string	- character data, including the max number of characters allowable. (i.e., string8 has a max of 8 chars)

5-6.3 OUTPUT DATA FORMAT: Output data from the Model 8312 consists of a series of ASCII digits and message strings, terminated with an ASCII Line-Feed character (0AH), in response to a program message that contains one or more query commands. In the case of multiple query commands in the same program message, the data resulting from each of the individual message units will be separated by an ASCII comma (2CH) character.

5-6.4 NOTATIONAL CONVENTION.

- [] Brackets indicate optional arguments or parameters.
- { } One and only one of the enclosed entries must be selected unless the field is also surrounded by brackets, in which case it is optional.
- ... Ellipses indicate that the preceding argument or parameter may be repeated.
- [,...] The preceding item may be repeated, but each repetition must be separated by a comma.

5-8. 488.2 COMMON COMMANDS

*CLS	Function: Clears the Status Byte and Event Status Registers. Syntax: *CLS Argument(s): none Remarks: This function is used to clear the Status Byte and the Event Status Registers. Return Value: none Example(s): *CLS
*ESE	Function: Sets the Event Status Enable Register. Syntax: *ESE <i>mask</i> Argument(s): <i>mask</i> integer bitmask Remarks: This function is used to set the Event Status Enable Register to the value specified by <i>mask</i> . Return Value: none Example(s): *ESE 255
*ESE?	Function: Reads the Event Status Enable Register. Syntax: *ESE? Argument(s): none Remarks: This function is used to read the Event Status Enable Register. Return Value: <i>mask</i> integer register mask Example(s): *ESE? returns the following '255'
*ESR?	Function: Reads the Event Status Register Syntax: *ESR? Argument(s): none Remarks: This function is used to read the Event Status Register. Reading the register clears it. Return Value: <i>reg</i> integer register Example(s): *ESR? returns the following '128'
*SRE	Function: Sets the Status Byte Enable Register Syntax: *SRE <i>mask</i> Argument(s): <i>mask</i> integer bitmask Remarks: This function is used to set the Status Byte Enable Register to the value specified by <i>mask</i> . Return Value: none Example(s): *SRE 255
*SRE?	Function: Reads the Status Byte Enable Register. Syntax: *SRE? Argument(s): none Remarks: This function is used to read the Status Byte Enable Register. Return Value: <i>mask</i> integer register mask Example(s): *SRE? returns the following '255'
*STB?	Function: Reads the Status Byte Register. Syntax: *STB? Argument(s): none Remarks: This function is used to read the Status Byte Register. Return Value: <i>reg</i> integer register Example(s): *STB? returns the following '96'
*IDN?	Function: Reads the system identification information. Syntax: *IDN? Argument(s): none Remarks: This function is used to read the system identification information, which is a string consisting of the following data: manufacturer, model, serial number, and firmware version. Return Value: <i>mfg</i> integer count of devices Example(s): *IDN? returns the following 'Weinschel,8312 Series, 123, 1.00A'

*RST	Function: Performs a device reset. Syntax: *RST Argument(s): none Remarks: This function is used to reset the device. Return Value: none Example(s): *RST
*OPC	Function: Operation complete service request. Syntax: *OPC Argument(s): none Remarks: This function generates the Operation Complete message (OPC) in the Standard Event Status Register when all pending device operations have finished. Return Value: none Example(s): *OPC
*OPC?	Function: Operation complete query Syntax: *OPC? Argument(s): none Remarks: This function loads a '1' into the output queue when the Program Message Unit is executed. Its primary use is to provide an indication of command completion by including the command as the last one in a series of commands. Return Value: 1 integer command completed Example(s): SAVE ASSIGN; *OPC? returns a '1' when the SAVE ASSIGN command completes.
*WAI	Function: Wait To Continue Syntax: *WAI Argument(s): none Remarks: This function prevents the 8312 Series from executing any further commands or queries until there are no pending operations. The 8312 Series executes all commands sequentially, and does not allow overlapping commands. Return Value: none Example(s): *WAI

5-9. GENERAL COMMANDS:

CHAN	Function: Selects the currently active channel Syntax: CHAN <i>chnum</i> Argument(s): <i>chnum</i> integer channel number Remarks: This function is used to select the currently active channel. Return Value: none Example(s): CHAN 1
CHAN?	Function: Reads the current channel number Syntax: CHAN? Argument(s): none Remarks: This function is used to read the currently active channel number. Return Value: <i>chnum</i> integer current channel number Example(s): CHAN? returns '1'
ATTN	Function: Set attenuation Syntax: ATTN <i>atten</i> Argument(s): <i>atten</i> real desired value, in dB Remarks: This function sets the attenuation of the currently selected channel to <i>atten</i> . Return Value: none Example(s): ATTN 63 ATTN 12.25 ATTN 45.0
ATTN?	Function: Read attenuation Syntax: ATTN? Argument(s): none Remarks: This function reads the attenuation of the currently selected channel. Return Value: <i>atten</i> real attenuation value, in dB Example(s): ATTN? returns '63.00'
REL	Function: Sets relative display mode for the current channel Syntax: REL <i>mode</i> Argument(s): <i>mode</i> integer relative mode on/off Remarks: This function is used to set the relative display mode of operation for the current channel. A value of 0 for the parameter <i>mode</i> will turn relative mode off, while a value of 1 will turn relative mode on. Return Value: none Example(s): REL 1
REF	Function: Sets reference Syntax: REF Argument(s): none Remarks: This function sets the reference value for the active channel to the current attenuation setting. This command is used for the REL and RELATTN functions. Return Value: none Example(s): REF; REL 1 sets the reference, and turns on relative mode
REF?	Function: Read reference setting Syntax: REF? Argument(s): none Remarks: This function reads the reference setting of the currently selected channel. Return Value: <i>refatten</i> real reference attenuation value, in dB Example(s): REF? returns '30.00'

RELATTN	<p>Function: Sets attenuation relative to the reference setting</p> <p>Syntax: RELATTN <i>atten</i></p> <p>Argument(s): <i>atten</i> real desired value, in dB</p> <p>Remarks: This function sets the attenuation of the currently selected channel to <i>atten</i>, relative to the reference value set when the REL command was executed.</p> <p>Return Value: none</p> <p>Example(s): RELATTN 10 increases the attenuation setting 10dB from the reference setting RELATTN -10 decreases the attenuation setting by 10dB from the reference setting 15.</p>
RELATTN?	<p>Function: Read relative attenuation of the current channel</p> <p>Syntax: RELATTN?</p> <p>Argument(s): none</p> <p>Remarks: This function reads the relative attenuation of the currently selected channel.</p> <p>Return Value: <i>relatten</i> real relative attenuation value, in dB</p> <p>Example(s): RELATTN? returns '-10.00'</p>
STEPSIZE	<p>Function: Sets attenuation stepsize for the current channel</p> <p>Syntax: STEPSIZE <i>atten</i></p> <p>Argument(s): <i>atten</i> real desired stepsize value, in dB</p> <p>Remarks: This function sets the attenuation stepsize for the INCR and DECR commands for the current channel to <i>atten</i>. The default value of the attenuator's stepsize is the intrinsic resolution of the attenuator, i.e., a 127dB/1dB step attenuator has a default stepsize of 1dB.</p> <p>Return Value: none</p> <p>Example(s): STEPSIZE 10 changes the stepsize to 10dB</p>
STEPSIZE?	<p>Function: Read attenuation stepsize</p> <p>Syntax: STEPSIZE?</p> <p>Argument(s): none</p> <p>Remarks: This function reads the attenuation stepsize of the current channel.</p> <p>Return Value: <i>atten</i> real attenuation stepsize value, in dB</p> <p>Example(s): STEPSIZE? returns '10.00'</p>
INCR	<p>Function: Increments attenuation</p> <p>Syntax: INCR</p> <p>Argument(s): none</p> <p>Remarks: This function increments the attenuation setting of the current channel by the value of the attenuator's programmed stepsize (see STEPSIZE command).</p> <p>Return Value: none</p> <p>Example(s): INCR</p>
DECR	<p>Function: Decrements attenuation</p> <p>Syntax: INCR</p> <p>Argument(s): none</p> <p>Remarks: This function decrements the attenuation setting of the current channel by the value of the attenuator's programmed stepsize (see STEPSIZE command).</p> <p>Return Value: none</p> <p>Example(s): DECR</p>

6. MAINTENANCE:

The following paragraphs provide general inspection and maintenance guide-lines for the 8312 Series **SmartStep** Hot-Switching High Power Attenuator Units.

6-1. INSPECTION: Perform a visual inspection in conjunction with the maintenance activities schedule when a malfunction is suspected, or whenever an assembly is removed or replaced.

6-2. PREVENTIVE MAINTENANCE: While the 8312 requires very little preventive maintenance, it should not be subjected to physical abuse, severe mechanical shock, high humidity, or operating temperatures outside the specification range. The instrument should be kept free of excessive dirt and dust, since these can interfere with connector functions and with normal heat dissipation. For cleaning instructions refer to paragraph 6-3 (special cleaning instructions). The following paragraphs provide the preventive maintenance that is to be performed on the Unit.

Care should be taken to prevent strain on the interconnecting cables, since damage here may not always be apparent. Occasionally check the external cables and connectors for signs of cracked insulation and/or bent or worn pins. Tests show that connectors must be clean for accuracy and stability. This requires an inspection and cleaning of each connector immediately before use. For connector cleaning instructions, refer to paragraph 6-3. When cleaning precautions are observed regularly, connectors can maintain their stability for over several thousand connection cycles. Refer to Appendix A for more information about cables and connectors.

6-3. SPECIAL CLEANING INSTRUCTIONS: The cleaning procedures for 8312 are divided into five general groups: microwave coaxial cable assemblies, circuit card and modules; machined surfaces and hardware, chassis cleaning, and connector cleaning.

6-3.1. MICROWAVE COAXIAL CABLE ASSEMBLIES: Appendix A (located at the end of this manual) provides all the necessary procedures for care, cleaning, and handling of microwave coaxial cable assemblies.

6-3.2 CIRCUIT CARDS AND MODULES: A protective coating is applied to circuit cards for protection from moisture, arcing, short-circuiting, and abrasion. To remove light dirt from circuit cards and modules proceed as follows:



CAUTION

- DO NOT use a nylon bristle brush in the solvent as the bristles may dissolve and cause damage to the circuit card or component.
 - DO NOT use ultrasonic cleaning on parts or assemblies containing electrical or electronic components.
 - DO NOT bend pins of electrical connectors when using fiber-bristle brush.
- a. Briskly brush isopropyl alcohol onto area to be cleaned with fiber-bristle brush.
 - b. Carefully remove residue with a clean lint-free cloth and repeat step "a" as a rinse.



WARNING

Compressed air used for cleaning and/or drying can create airborne particles that may enter the eye. Goggles/ faceshields should be worn. DO NOT direct air stream towards self or other personnel. Pressure should be restricted to a maximum 15 psi to avoid personal injury.

- c. When parts are thoroughly clean, dry parts using 5 psi of clean moisture free compressed air or preferably dry nitrogen (pressurized spray will work well).

6-3.3 MACHINED SURFACES AND HARDWARE: To remove light dirt and dust from mechanical parts such as castings, covers and other hardware proceed as follows:

**WARNING**

Compressed air used for cleaning and/or drying can create airborne particles that may enter the eye. Goggles/ faceshields should be worn. DO NOT direct air stream towards self or other personnel. Pressure should be restricted to a maximum 15 psi to avoid personal injury.

**CAUTION**

- Under no circumstances use a wire brush, steel wool, or abrasive compound. Using these items will cause extensive damage to the instrument's surface.
 - DO NOT use a nylon bristle brush in solvent as the bristles may dissolve and cause damage to the circuit card or component.
- a. Use 5 psi of clean, moisture-free compressed air or preferably dry nitrogen to blow loose dirt and dust from surface of item.
 - b. Briskly brush isopropyl alcohol onto area to be cleaned with a fiber-bristle brush.
 - c. Remove residue with lint-free cloth and repeat step "b" as a rinse.
 - d. When parts are thoroughly clean, dry parts using 5 psi of clean, moisture-free compressed air or preferably dry nitrogen.
 - e. Clean smaller mechanical parts or hardware by dipping into a container of isopropyl alcohol. Remove dirt by brushing with fiber-bristle brush after parts have been immersed for several hours.
 - f. Remove parts from isopropyl alcohol and rinse by immersing into a different container of isopropyl alcohol.
 - g. When parts are thoroughly cleaned, dry parts using 5 psi of clean, moisture-free compressed air or preferably dry nitrogen.

6-3.4 CHASSIS CLEANING: Clean chassis using a lint-free cloth moistened with water and mild detergent. For harder to clean areas, such as inside corners of chassis, use a vacuum cleaner.

6-3.5 CONNECTOR CLEANING: Where small amounts of rust, corrosion, and/or oxide deposits are present on connectors, clean externally with a soft-bristle brush, aluminum wool, or internally with an acid brush; then wash with a non-corrosive solvent. MIL-C-83112 is recommended. Exercise care to ensure no metal filing or residue remains inside the connector and the connector is thoroughly dry. Where rust, corrosion, and/or oxide deposits are present in large quantities, replace the connector.

6-4. LINE VOLTAGE FUSE REPLACEMENT: The following steps provide procedures to replace the line voltage Fuse Assembly. This unit accepts a F1.5A, 250 Vac fuse for 115 Vac.

**WARNING**

Sufficient power levels are present at the Power Input Assembly to cause personal injury. Ensure that the instrument power cord is DISCONNECTED before attempting to change fuses.

**CAUTION**

DO NOT connect or apply power to this instrument until the Power Entry Module Assembly has been adjusted to the operational line voltage.

- a. Disconnect the power cord from the Power Entry Module Assembly.
- b. Use a small screwdriver to carefully open the Fuse Drawer.
- c. Slide out Fuse Drawer located in the center of the Power Entry Module Assembly.
- d. Remove defective fuse and replace with the correct fuse (Refer to applicable parts list for fuse part number).
- e. Snap the Fuse Drawer shut and re-connect ac power cord.

7. REPLACEABLE PARTS LIST:

This section lists and describes the parts located in Standard 8312 Series SmartStep Hot-Switching High Power Attenuator Units (P/N 193-8067-X). The Replaceable Parts Lists (RPL) is intended for use in identifying, locating, and requisitioning assemblies and components for the Model 8312.

7-1 UNDERSTANDING REFERENCE DESIGNATORS: All assemblies and electrical parts are identified by standard reference designators (resistors R1, for example). Reference designators are used in parts lists and on parts identification drawings. The title of a parts list or drawing contains the reference designator or the assembly or subassembly to which it applies. The designators in the parts list, as a prefix, but omitted from the list to make it easier to locate a specific part. To complete a reference designator in a parts list, precede the designator for the specific part (DS1, for example) with the designator in the title (A6, for example) to form a complete reference designator for the part (in this case, A6DS1).

7-2 ORDERING INFORMATION: When ordering parts from Weinschel, please include the following information:

- MCE / Weinschel part number.
- Description of the component or part.
- Model and serial number of the instrument.
- Assembly number and assembly revision (if any) from the assembly (this information is on the component side of the PCB).

7-3 DRAWING NUMBER: The MCE / Weinschel part number consists of a basic number with a dash number. The basic number should cross reference to a drawing number for most of the items. For those items that do not have a drawing number, the manufacturers part number is provided.

7-4 REPLACEABLE PARTS LIST (RPL): This RPL contains a breakdown of the instrument into its major assemblies and detailed parts. The following paragraphs describe the contents of each column of the RPL.

7-4.1 REFERENCE DESIGNATOR: This column contains reference designations arranged in alphanumeric sequence. The letters A thru Z have precedence, followed by numerals 0 thru 9. In addition to the reference designators that are listed, some mechanical parts are also listed. These items lack reference designators and are included because they are considered subject to wear and/or breakage, or because they are custom (non-standard) hardware or parts that might become lost or damaged. This column contains the word N/A for those items or parts not having a reference designator.

7-4.2 DESCRIPTION: This column contains the nomenclature located in the title block of the engineering drawing by the designing activity. The noun name is listed first, followed by modifiers and descriptive information to completely identify the part or assembly.

7-4.3 PART NUMBER: This column contains the Weinschel part number assigned to an assembly, sub-assembly, or detailed part. This also includes Weinschel numbers for specification control, source control, and altered items drawings.

7-4.4 VENDOR PART NO.: This column contains manufacturers part numbers for those parts Weinschel purchases, as off the shelf items and assigns Weinschel part numbers for internal control only. These parts may be ordered through the manufacturer or through Weinschel by the Weinschel part number.

7-4.5 CAGE CODE: This column provides the Commercial and Government Entity (CAGE) code on the same line as the applicable part number. Codes, names, and addresses of vendors with an assigned CAGE are listed in Cataloging Handbook H4-1 and H4-2. Vendors that have not been assigned CAGE codes by the government are identified by the word NONE in this column. The names and addresses of these vendors can be obtained from Weinschel. Part numbers that have no CAGE numbers listed are manufactured or altered by Weinschel.

7-4.6 ASSEMBLY AND COMPONENT LOCATION: The assembly/component location and schematic diagrams for the different 8312 series models are located in rear of this manual by the drawing number. Drawing find numbers have also been included to help locate components or hardware.

Model 8312-31-F, Hot-Switching High Power Attenuator Unit Assembly Replaceable Parts List (P/N 193-8067):

Find No.	Part Number	Description	Quantity Used	Reference Designator	CAGE Code	Vendor Part Number
1	193-8065	ENCLOSURE, MODIFIED	1	NA		
2	193-8078	CHASSIS	1	NA		
3	193-8079	HEATSINK	1	NA		
4	193-8080	SUPPORT, HEATSINK	2	NA		
5	193-8066	OVERLAY, MODEL 8312	1	NA		
6	1458-2	TERMINATION, 3.5mm MALE	1	AT2		
7	6493-0-11	FXD ATTEN, 0 dB	2	AT3, AT5		
8	1677572	FXD ATTEN, 1 dB	1	AT4		
10	1677603	FXD ATTEN, 2 dB	1	AT6		
11	1677631	FXD ATTEN, 3 dB	3	AT1, AT10, A11		
12	1677662	FXD ATTEN, 4 dB	1	AT8		
15	193-8072	ASSY, CABLE, SWITCH BD TO REG BD	1	W8		
16	193-8005-1	ASSY CABLE RS232 CONT TO R/P	1	W7		
17	193-8055-006	ASSY, PCB, SWITCH DRIVER	1	A2		
18	193-8023-001	ASSY, PCB, CONTROLLER, W/IEEE CONN	1	A1		
19	193-9306-000	ASSY, PCB, REGULATOR	1	A3		
20	193-8028-000	ASSY, PCB, CONTROL, FP	1	A4		
21	193-8029-001	ASSY, PCB, FP DISPLAY	1	A5		
22	193-9159	ASSY, CABLE, GND	1	W1		
23	193-9177	ASSY CABLE PWR/INPUT TO PSU	1	W2		
24	193-9612	CLAMP, ADDRESS CABLE	1	NA		
25	068-39-3	CABLE ASSY, 16 COND, RIBBON, 12 INCH LG	1	W3	D-KEY	A8PPG-1612M-ND
26	193-9126-000	ASSY, PCB, ADDRESS SWITCH	1	A6		
27	193-8073	ASSY, CABLE, CONT TO SWITCH BD	1	W4		
28	193-8075	ASSY, CABLE, POWER SUPPLY TO REG BD	1	W5		
29	193-9193-4	ASSY, CABLE, CONTRL TO FNT PNL DISPLAY	1	W6		
30	051-40	FUSE HOLDER, POWER INPUT, W/SWITCH	1	XF1	5245	PSOSXSS6B
31	052-1-1/5	FUSE 1.5 AMP, 250V	1	F1	75915	312.01.5
32	068-51	CORD PWR 3-CONDUCTOR DTCH 6.7FT 10A-125V NEMA5-15P/IEC320-C13	1	NA	16428	17506
33	021-27	FAN GUARD, 3.15 X 1.26	1	NA	OACZ	06325-M
34	021-29	GUARD, FAN, 80MM	1	NA	OACZ1	8172
35	001-400-28	PSU SWITCHER, +28 VDC, 1.8 AMP	1	A7	60975	GLC50-28
36	193-8074	ASSY, CABLE, CONT TO REG BD	1	W9		
37	193-8070	ASSY, SWITCH	1	S6		
38	193-8071	ASSY, SWITCH	5	S1B - S5B		
39	193-8081	ASSY, SWITCH	5	S1A - S5A		
40	7002-14	ADAPT COAX N/M TO SMA/F	2	NA		
41	068-32-2/5	COAXIAL CABLE ASSY, SMA M/M, CONFORMABLE, DC TO 18 GHz	3	W16 - W18		
42	068-32-3/0	COAXIAL CABLE ASSY, SMA M/M, CONFORMABLE, DC TO 18 GHz	5	W11, W13, W14, W15, W19	0	B068-32-3/0
43	068-32-4/0	COAXIAL CABLE ASSY, SMA M/M, CONFORMABLE, DC TO 18 GHz	2	W20, W21		068-32-4/0

Model 8312-31-F, Hot-Switching High Power Attenuator Unit Assembly Replaceable Parts List (P/N 193-8067):

Find No.	Part Number	Description	Quantity Used	Reference Designator	CAGE Code	Vendor Part Number
44	068-32-4/5	COAXIAL CABLE ASSY, SMA M/M, CONFORMABLE, DC TO 18 GHz	2	W22, W23		
45	068-32-5/0	COAXIAL CABLE ASSY, SMA M/M, CONFORMABLE, DC TO 18 GHz	5	W24 - W28		B068-32-5/0
46	068-32-8/5	COAXIAL CABLE ASSY, SMA M/M, CONFORMABLE, DC TO 18 GHz	1	W29		
47	068-32-3/5	COAXIAL CABLE ASSY, SMA M/M, CONFORMABLE, DC TO 18 GHz DC TO 18 GHz	2	W10, W12	93459	B068-32-3/5
48	068-32-10/0	COAXIAL CABLE ASSY, SMA M/M, CONFORMABLE, DC TO 18 GHz	1	W30		B068-32-10/0
49	068-32-12/0	COAXIAL CABLE ASSY, SMA M/M, CONFORMABLE, DC TO 18 GHz	1	W33		B068-32-12/0
50	068-55-7/0	CABLE ASSY, TYPE N MALE TO SMA MALE	1	W34	93459	068-55-7/0
51	063-165-2	CONN ADAPTER BLKHD MT N JACK/SMA JACK, DC-6 GHZ	2	NA	64671	#5203
52	MS35338-135	WASHER LOCK #4	42	NA		
53	MS15795-803	WASHER FLAT .125 ID .250 OD	42	NA		
54	MS51957-22	SCR PAN HD 4-40 X 1 1/4 LG	2	NA		
55	MS35649-244	NUT HEX #4	3	NA		
56	MS51957-15	SCR PAN HD 4-40 X 3/8 LG	14	NA		
57	MS51957-37	SCR PAN HD 6-32 X 1 3/4 LG	4	NA		
58	MS35649-264	NUT HEX #6	4	NA		
59	MS15795-805	WASHER FLAT .156 ID .312 OD	6	NA		
60	MS35338-137	WASHER LOCK #8	34	NA		
61	062-380-1	SCREW LOCK, HARDWARE KIT, METRIC, #6-32 UNC-2A EXT THDS	1	NA	779	554808-1
62	062-184-5	CONN SCREW LOCK, FEMALE	2	NA	71468	D20418-2
63	MS24693-C3	SCR FLAT HD 4-40 X 5/16 LG 100	9	NA		
64	MS51957-17	SCR PAN HD 4-40 X 1/2 LG	4	NA		
65	MS51957-19	SCR PAN HD 4-40 X 3/4 LG	22	NA		
66	MS51957-27	SCR PAN HD 6-32 X 5/16 LG	8	NA		
67	MS51957-33	SCR PAN HD 6-32 X 7/8 LG	22	NA		
68	MS51957-36	SCR PAN HD 6-32 X 1 1/2 LG	2	NA		
69	068-32-11/0	COAXIAL CABLE ASSY, SMA M/M, CONFORMABLE, DC TO 18GHz	2	W31, W32	0	B068-32-11/0
70	193-9349-2	ASSY, FAN	1	B1		
71	090-354	* LABEL WARNING, HIGH VOLTAGE	1	NA		
72	090-445	* LABEL, REFERENCE INSTRUCTION MANUAL	1	NA		
73	090-285	*NAMEPLATE HIGH VOLTAGE	1	NA		
74	090-353	* LABEL GROUND	1	NA		
75	074-912-2	RACK KIT, 5.22 W/O HANDLE	1	NA	24803	K3RMX-001A
76	090-301	* LABEL STD 1.5 X .75 IN	1	NA		
79	089-3508	ICD, HI POWER ATTEN, MODEL 8312	0	NA		
80	193-8069	WIRING DIAGRAM	0	NA		
81	IM-359	O & S MANUAL, MODEL	1	NA		

Refer to Weinschel Drawing 193-8067 for parts location.

Model 8312-15-F, Hot-Switching High Power Attenuator Unit Assembly Replaceable Parts List (P/N 193-8067-1):

Find No.	Part Number	Description	Quantity Used	Reference Designator	CAGE Code	Vendor Part Number
1	193-8065	ENCLOSURE, MODIFIED	1	NA		
2	193-8078	CHASSIS	1	NA		
3	193-8079	HEATSINK	1	NA		
4	193-8080	SUPPORT, HEATSINK	2	NA		
5	193-8066	OVERLAY, MODEL 8312	1	NA		
6	1458-2	TERMINATION, 3.5mm MALE	1	AT2		
7	6493-0-11	FXD ATTEN, 0 dB	2	AT3, AT5		
8	167-7572	FXD ATTEN, 1 dB	1	AT4		
10	167-7603	FXD ATTEN, 2 dB	1	AT6		
11	167-7631	FXD ATTEN, 3 dB	2	AT1, AT10		
12	167-7662	FXD ATTEN, 4 dB	1	AT8		
15	193-8072	ASSY, CABLE, SWITCH BD TO REG BD	1	W8		
16	193-8005-1	ASSY CABLE RS232 CONT TO R/P	1	W7		
17	193-8055-006	ASSY, PCB, SWITCH DRIVER	1	A2		
18	I	ASSY, PCB, CONTROLLER, W/IEEE CONN	1	A1		
19	193-9306-000	ASSY, PCB, REGULATOR	1	A3		
20	193-8028-000	ASSY, PCB, CONTROL, FP	1	A4		
21	193-8029-001	ASSY, PCB, FP DISPLAY	1	A5		
22	193-9159	ASSY, CABLE, GND	1	W1		
23	193-9177	ASSY CABLE PWR/INPUT TO PSU	1	W2		
24	193-9612	CLAMP, ADDRESS CABLE	1	NA		
25	068-39-3	CABLE ASSY, 16 COND, RIBBON, 12 INCH LG	1	W3	D-KEY	A8PPG-1612M-ND
26	193-9126-000	ASSY, PCB, ADDRESS SWITCH	1	A6		
27	193-8073	ASSY, CABLE, CONT TO SWITCH BD	1	W4		
28	193-8075	ASSY, CABLE, POWER SUPPLY TO REG BD	1	W5		
29	193-9193-4	ASSY, CABLE, CONTRL TO FNT PNL DISPLAY	1	W6		
30	051-40	FUSE HOLDER, POWER INPUT, W/SWITCH	1	XF1	5245	PSOSXSS6B
31	052-1-1/5	FUSE 1.5 AMP, 250V	1	F1	75915	312.01.5
32	068-51	CORD PWR 3-CONDUCTOR DTCH 6.7FT 10A-125V NEMA5-15P/IEC320-C13	1	NA	16428	17506
33	021-27	FAN GUARD, 3.15 X 1.26	1	NA	OACZ	06325-M
34	021-29	GUARD, FAN, 80MM	1	NA	OACZ1	8172
35	001-400-28	PSU SWITCHER, +28 VDC, 1.8 AMP	1	A7	60975	GLC50-28
36	193-8074	ASSY, CABLE, CONT TO REG BD	1	W9		
37	193-8070	ASSY, SWITCH	1	S6		
38	193-8071	ASSY, SWITCH	4	S1B - S4B		
39	193-8081	ASSY, SWITCH	4	S1A - S4A		
40	7002-14	ADAPT COAX N/M TO SMA/F	2	NA		
41	068-32-2/5	COAXIAL CABLE ASSY, SMA M/M, CONFORMABLE, DC TO 18 GHz	3	W16 - W18		
42	068-32-3/0	COAXIAL CABLE ASSY, SMA M/M, CONFORMABLE, DC TO 18 GHz	5	W11, W13, W14, W15, W19	0	B068-32-3/0
43	068-32-4/0	COAXIAL CABLE ASSY, SMA M/M, CONFORMABLE, DC TO 18 GHz	2	W20, W21		068-32-4/0

Model 8312-15-F, Hot-Switching High Power Attenuator Unit Assembly Replaceable Parts List (P/N 193-8067-1):

Find No.	Part Number	Description	Quantity Used	Reference Designator	CAGE Code	Vendor Part Number
44	068-32-4/5	COAXIAL CABLE ASSY, SMA M/M, CONFORMABLE, DC TO 18 GHz	2	W22, W23		
45	068-32-5/0	COAXIAL CABLE ASSY, SMA M/M, CONFORMABLE, DC TO 18 GHz	5	W24 - W28		B068-32-5/0
46	068-32-8/5	COAXIAL CABLE ASSY, SMA M/M, CONFORMABLE, DC TO 18 GHz	1	W29		
47	068-32-3/5	COAXIAL CABLE ASSY, SMA M/M, CONFORMABLE, DC TO 18 GHz	2	W10, W12	93459	B068-32-3/5
48	068-32-10/0	COAXIAL CABLE ASSY, SMA M/M, CONFORMABLE, DC TO 18 GHz	1	W30		B068-32-10/0
49	068-32-12/0	COAXIAL CABLE ASSY, SMA M/M, CONFORMABLE, DC TO 18 GHz	1	W33		B068-32-12/0
50	068-55-7/0	CABLE ASSY, TYPE N MALE TO SMA MALE	1	W34	93459	068-55-7/0
51	063-165-2	CONN ADAPTER BLKHD MT N JACK/SMA JACK, DC-6 GHZ	2	NA	64671	#5203
52	MS35338-135	WASHER LOCK #4	42	NA		
53	MS15795-803	WASHER FLAT .125 ID .250 OD	42	NA		
54	MS51957-22	SCR PAN HD 4-40 X 1 1/4 LG	2	NA		
55	MS35649-244	NUT HEX #4	3	NA		
56	MS51957-15	SCR PAN HD 4-40 X 3/8 LG	14	NA		
57	MS51957-37	SCR PAN HD 6-32 X 1 3/4 LG	4	NA		
58	MS35649-264	NUT HEX #6	4	NA		
59	MS15795-805	WASHER FLAT .156 ID .312 OD	6	NA		
60	MS35338-137	WASHER LOCK #8	34	NA		
61	062-380-1	SCREW LOCK, HARDWARE KIT, METRIC, #6-32 UNC-2A EXT THDS	1	NA	779	554808-1
62	062-184-5	CONN SCREW LOCK, FEMALE	2	NA	71468	D20418-2
63	MS24693-C3	SCR FLAT HD 4-40 X 5/16 LG 100	9	NA		
64	MS51957-17	SCR PAN HD 4-40 X 1/2 LG	4	NA		
65	MS51957-19	SCR PAN HD 4-40 X 3/4 LG	22	NA		
66	MS51957-27	SCR PAN HD 6-32 X 5/16 LG	8	NA		
67	MS51957-33	SCR PAN HD 6-32 X 7/8 LG	22	NA		
68	MS51957-36	SCR PAN HD 6-32 X 1 1/2 LG	2	NA		
69	068-32-11/0	COAXIAL CABLE ASSY, SMA M/M, CONFORMABLE, DC TO 18GHz	2	W31, W32	0	B068-32-11/0
70	193-9349-2	ASSY, FAN	1	B1		
71	090-354	* LABEL WARNING, HIGH VOLTAGE	1	NA		
72	090-445	* LABEL, REFERENCE INSTRUCTION MANUAL	1	NA		
73	090-285	*NAMEPLATE HIGH VOLTAGE	1	NA		
74	090-353	* LABEL GROUND	1	NA		
75	074-912-2	RACK KIT, 5.22 W/O HANDLE	1	NA	24803	K3RMX-001A
76	090-301	* LABEL STD 1.5 X .75 IN	1	NA		
79	089-3508	ICD, HI POWER ATTEN, MODEL 8312	0	NA		
80	193-8069	WIRING DIAGRAM	0	NA		
81	IM-359	O & S MANUAL, MODEL	1	NA		

Refer to Weinschel Drawing 193-8067 for parts location.

8. ACCESSORIES:

Part Number	<u>Description</u>
193-TBD	Rack Mounting Kit

9. CONTACTING MCE/WEINSCHEL:

In the event of a malfunction, contact MCE/Weinschel Corporation. An apparent malfunction of an instrument or component may be diagnosed over the phone by first contacting the Customer Service Department at MCE/Weinschel Corporation. DO NOT send the instrument or component back to the factory without prior authorization. When it is necessary to return an item, state the symptoms, catalog and type number of the instrument or component, and date of original purchase. Also write the Company name and your name and phone number on a card and tape the card to the item returned. Page provides further information regarding preparation of a unit for reshipment. Contact Weinschel Corporation Customer Service Department as follows:

- Via mail:** MCE / Weinschel Corporation
5305 Spectrum Drive
Frederick, MD 21703-7362
U.S.A.
- Via Telefax:** 301-846-9116
- Via Phone:** Call TOLL FREE 800-638-2048
Toll call # 301-846-9222
- Via Website:** www.weinschel.com
- Via e-mail:** sales@weinschel.com

10. MCE / WEINSCHEL WARRANTY:

PRODUCTS - MCE/Weinschel Corporation warrants each product it manufactures to be free from defects in material and workmanship under normal use and service anywhere in the world. MCE/Weinschel Corporation's only obligation under this Warranty is to repair or replace, at its plant, any product or part thereof that is returned with transportation charges prepaid to MCE/Weinschel Corporation by the original purchaser within ONE YEAR from the date of shipment.

The foregoing Warranty does not apply MCE/Weinschel Corporation's sole opinion to products that have been subject to improper or inadequate maintenance, unauthorized modifications, misuse, or operation outside the environmental specifications for the product.

SOFTWARE PRODUCTS- MCE/Weinschel Corporation software products are supplied without representation or Warranty of any kind. MCE/Weinschel Corporation, therefore, assumes no responsibility and will not accept liability (consequential or otherwise) arising from the use of program materials, disk, or tape.

The Warranty period is controlled by the Warranty document furnished with each product and begins on the date of shipment. All Warranty returns must be authorized by MCE/Weinschel Corporation prior to their return.

MCE/Weinschel Corporation's Quality System Certified to:

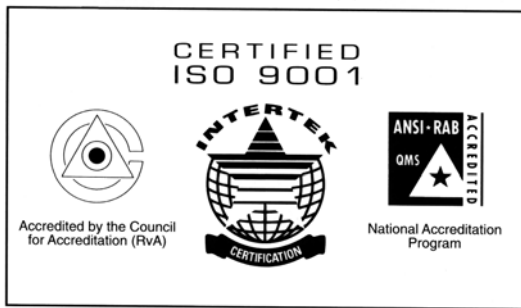

Certificate No. 94-289D