

BEU8637-12

Independent Balancing for Two 12-Cell Batteries
Cell Voltage Monitoring and Telemetry



www.aeroflex.com/BEU

March 21, 2008

Description

The Aeroflex 8637-12 is a Lithium-Ion cell balancing system. It controls the balancing of one or two batteries, each consisting of a series stack of Lithium-Ion cells to ensure that each cell is precisely charged to its proper level of energy and to monitor each cell's operational voltage.

The cell balancing circuitry uses a set of bilateral DC-DC converters which tie each cell of a battery to a common share bus. Cell charge is distributed among the multiple cells so that the charge of each cell is automatically matched to the average charge of the other cells.



Features

- Cell Balancing to within $\pm 5.0\text{mV}$
- Cell Voltage Monitoring Accuracy $\pm 10.0\text{mV}$ ($\pm 20.0\text{mV}$ Space Mission Life)
- Total Battery Voltage Monitoring Accuracy $\pm 0.3\%$ of Full Scale
- Supports up to 12 Lithium-Ion battery cells in series per stack
- Battery Drain Current at Balance 15mA Max for each 12 cell stack
- Discrete output lines for critical signaling with user definable thresholds:
 - Overvoltage Protection 4.40V typ
 - Cell Voltage High 4.20V typ
 - Cell Voltage Low 3.20V typ
- MIL-STD-1553B telemetry for data logging and monitoring

Safety

The safety of Lithium-Ion battery technology requires that extreme care be taken in the provisions made for cell charging and cell monitoring.

Precision measurements of each of the individual cell voltages in the battery stack and precise charge balancing to each individual cell are critical.

The Aeroflex 8637-12 provides the necessary precision of control and monitoring to ensure that safety.

Discrete logic outputs are provided for critical signaling, enabling the user to initiate load shedding and/or to halt charging.

Low operating losses enable continuous operation. Continuous balancing provides maximum protection against any one cell becoming overcharged.

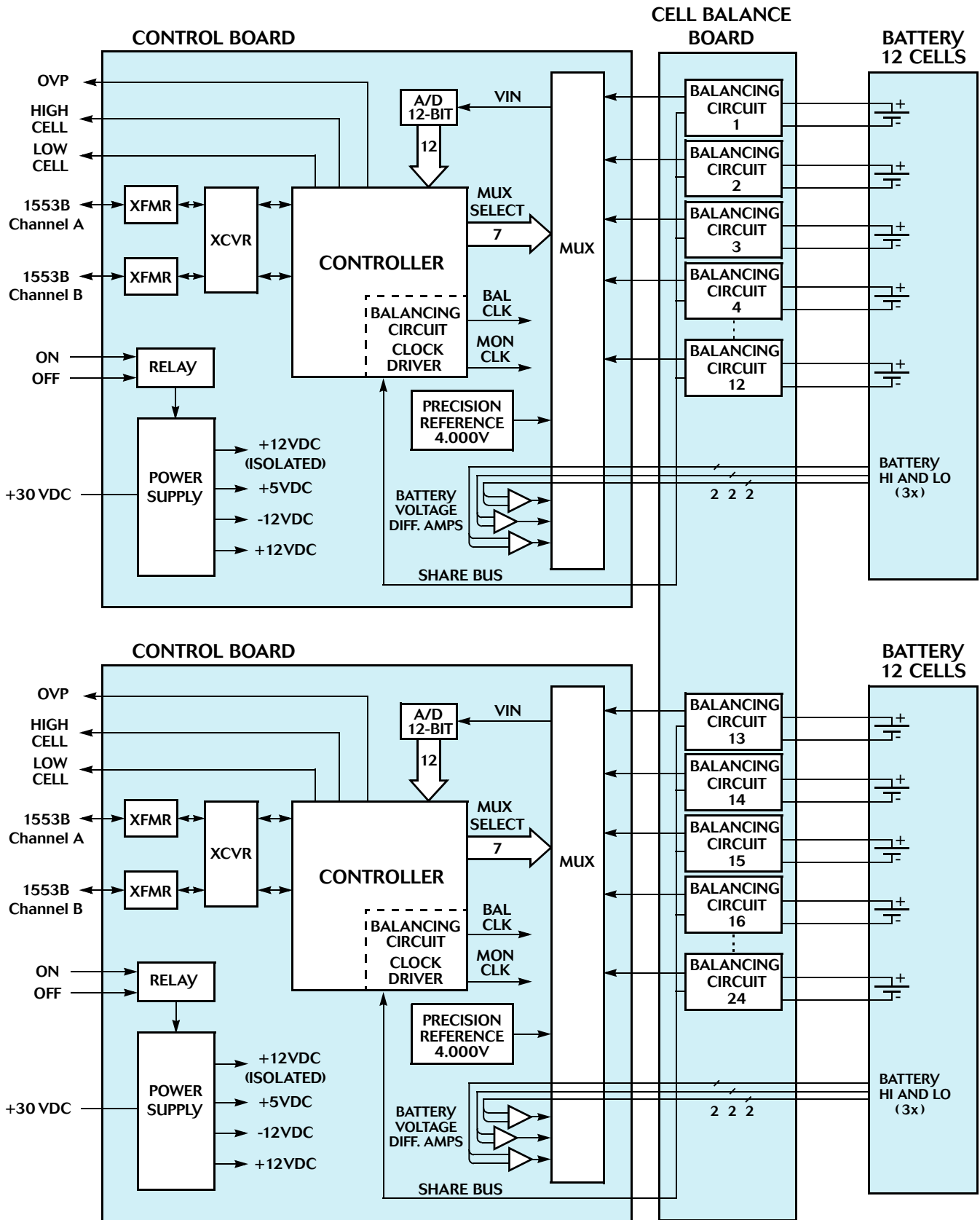

Block Diagram

8637-12 Operating Details

Battery Cell Balancing

Provides 12 individual continuous balancing circuits per stack.

Maximum Cell Balancing Current Limit

Each cell is provided with a 1Amp fuse for overload interrupt in the event of a shorted cell to protect the remaining cell balance functionality.

Cell Balancing Accuracy

When connected to a battery, the 8637-12 provides balancing currents into each of the battery's cells. The directions and the magnitudes of the individual currents are proportional to the deviations of the cell voltages from the average cell voltage. The transfer ratio of voltage to current is 1.0 Ohm nominal and is satisfied for cell voltages of up to 4.2V.

Battery Cell Current Drawn in Off State

In the off state, the differential mode battery cell current drawn by each cell balancing circuit is less than 50 μ A.

Battery Cell Voltage Monitoring

Measures cell voltages for up to two 12-cell batteries.

4V and 0V References for Calibration

Provides 4V and 0V references for cell voltage telemetry calibration.

Battery and Cell Protection

Incorporates overvoltage protection (OVP) circuits. These circuits monitor all of the battery cell voltages and only register the highest of all cell voltages monitored. When a cell voltage threshold of 4.40V is reached, the protection circuit output changes state and latches within 50mS.

Battery Cell Overvoltage Latch Output

The status of the OVP latch is provided by telemetry as specified in Tables II, III & IV and also as a discrete output.

Recovery from Cell Overvoltage Indication

The OVP latch is reset by a 1553B reset command or by recycling the input power.

Highest Battery Cell Voltage Telemetry

Provides highest battery cell voltage telemetry as specified in Tables I & IV.

Lowest Battery Cell Voltage Telemetry

Provides lowest battery cell voltage telemetry as specified in Tables I & IV.

Test Points

Provides test points for total battery voltage, low cell indicator and high cell indicator. Access to the total battery voltage is provided to permit pre-charging before connection to the battery.

MIL-STD-1553B Telemetry & Commands (Each 12-cell battery)

Analog or bi-level telemetry can be requested from either the primary or the redundant controller and reported over the dual redundant 1553B interface with the RT addresses configurable at the J1 and J4 connectors.

Analog Telemetry

Each analog telemetry item can be requested individually on sub-addresses 18, 19 or 22.

First a 1553B receive command with one data word as defined in Table I, which specifies the telemetry item being requested, must be issued. After a minimum delay of 1.2ms, the data can be retrieved by sending a 1553B transmit command for one data word on the same sub-address on which the request was initiated.

The 12-bit data reply is left justified in the 16-bit 1553B data word with the four LSBs set to "0".

Table I – Analog Telemetry (Each 12-cell battery)

Item	Telemetry Title	Telemetry Reply Scale	1 st Data Word of 1553B Receive Command (Hex)
1	4V Reference	-0.40V to 4.89V	0800
2	0V Reference	-0.40V to 4.89V	0803
3	Total Battery Voltage 1	0V to 61.44V	0805
4	Total Battery Voltage 2	0V to 61.44V	0806
5	Total Battery Voltage 3	0V to 61.44V	0809
6	Share Bus Voltage	0V to 5.12V	080A
7	Cell 1 Voltage	0V to 5.12V	0811
8	Cell 2 Voltage	0V to 5.12V	0812
9	Cell 3 Voltage	0V to 5.12V	0814
10	Cell 4 Voltage	0V to 5.12V	0817
11	Cell 5 Voltage	0V to 5.12V	0818
12	Cell 6 Voltage	0V to 5.12V	081B
13	Cell 7 Voltage	0V to 5.12V	081D
14	Cell 8 Voltage	0V to 5.12V	081E
15	Cell 9 Voltage	0V to 5.12V	0821
16	Cell 10 Voltage	0V to 5.12V	0822
17	Cell 11 Voltage	0V to 5.12V	0824
18	Cell 12 Voltage	0V to 5.12V	0827
19	Cell 13 Voltage	0V to 5.12V	0828
20	Cell 14 Voltage	0V to 5.12V	082B
21	Cell 15 Voltage	0V to 5.12V	082D
22	Cell 16 Voltage	0V to 5.12V	082E
23	Cell 17 Voltage	0V to 5.12V	0830
24	Cell 18 Voltage	0V to 5.12V	0833
25	Cell 19 Voltage	0V to 5.12V	0835
26	Cell 20 Voltage	0V to 5.12V	0836
27	Cell 21 Voltage	0V to 5.12V	0839
28	Cell 22 Voltage	0V to 5.12V	083A
29	Cell 23 Voltage	0V to 5.12V	083C
30	Cell 24 Voltage	0V to 5.12V	083F
31	Lowest Cell Voltage	0V to 5.12V	0871
32	Highest Cell Voltage	0V to 5.12V	0872

1/ For Battery A. 2/ For Battery B.

Bi-Level Telemetry

Bi-level telemetry can be requested on sub-addresses 18, 19 or 22.

First a 1553B receive command with one data word as defined in Table II, which specifies the telemetry item being requested, must be issued. After a minimum delay of 1.2ms, the data can be retrieved by sending a 1553B transmit command for one data word on the same sub-address on which the request was initiated.

Table II – Bi-level Telemetry

Item	Telemetry Title	Status	Reply Bit	1 st Data Word of 1553B Receive Command (Hex)
1	Overvoltage Latch Status	1 = Set	D13	0C80

32-Word Telemetry

To reduce data bus bandwidth usage, the 8637-12 supports a 32-word telemetry request on sub-address 20 as defined in Table III.

First a 1553B receive command with one data word of AAAA(Hex) must be issued. After a minimum delay of 1.2ms, the data can be retrieved by sending a 1553B transmit command for 32 data words on sub-address 20.

Reply word 31 is a modulo-16 message count. This counter increments by one for each valid telemetry request.

The 12-bit analog data reply is left justified in the 16-bit 1553B data word with the four LSBs set to "0"..

Table III – 32-Word Telemetry

Item	Telemetry Title	Telemetry Type	Reply Word	Reply Bits
1	4V Reference	Analog	1	D(15:4)
2	Total Battery Voltage 1	Analog	2	D(15:4)
3	Total Battery Voltage 2	Analog	3	D(15:4)
4	Total Battery Voltage 3	Analog	4	D(15:4)
5	Share Bus Voltage	Analog	5	D(15:4)
6	Reserved	-	6	D(15:4)
7	Cell 1 Voltage	Analog	7	D(15:4)
8	Cell 2 Voltage	Analog	8	D(15:4)
9	Cell 3 Voltage	Analog	9	D(15:4)
10	Cell 4 Voltage	Analog	10	D(15:4)
11	Cell 5 Voltage	Analog	11	D(15:4)
12	Cell 6 Voltage	Analog	12	D(15:4)
13	Cell 7 Voltage	Analog	13	D(15:4)
14	Cell 8 Voltage	Analog	14	D(15:4)
15	Cell 9 Voltage	Analog	15	D(15:4)
16	Cell 10 Voltage	Analog	16	D(15:4)
17	Cell 11 Voltage	Analog	17	D(15:4)
18	Cell 12 Voltage	Analog	18	D(15:4)
19	Cell 13 Voltage	Analog	19	D(15:4)
20	Cell 14 Voltage	Analog	20	D(15:4)
21	Cell 15 Voltage	Analog	21	D(15:4)
22	Cell 16 Voltage	Analog	22	D(15:4)
23	Cell 17 Voltage	Analog	23	D(15:4)
24	Cell 18 Voltage	Analog	24	D(15:4)
25	Cell 19 Voltage	Analog	25	D(15:4)
26	Cell 20 Voltage	Analog	26	D(15:4)
27	Cell 21 Voltage	Analog	27	D(15:4)
28	Cell 22 Voltage	Analog	28	D(15:4)
29	Cell 23 Voltage	Analog	29	D(15:4)
30	Cell 24 Voltage	Analog	30	D(15:4)
31	Message Count	Analog	31	D(15:0)
32	Overvoltage Latch Status	Bi-level	32	D13

1/ For Battery A. 2/ For Battery B.

8-Word Telemetry

To reduce data bus bandwidth usage, the 8637-12 supports an 8-word telemetry request on sub-address 24 as defined in Table IV.

First a 1553B receive command with one data word of 5555(Hex) must be issued. After a minimum delay of 1.2ms, the data can be retrieved by sending a 1553B transmit command for 8 data words on sub-address 24.

Reply word 8 is a modulo-16 message count. This counter increments by one for each valid telemetry request.

The 12-bit analog data reply is left justified in the 16-bit 1553B data word with the four LSBs set to "0".

Table IV – 8-Word Telemetry

Item	Telemetry Title	Telemetry Type	Reply Word	Reply Bits
1	Overvoltage Latch Status	Bi-level	1	D13
2	Reserved	-	2	-
3	Reserved	-	3	-
4	Reserved	-	4	-
5	OV Reference	Analog	5	D(15:4)
6	Lowest Cell Voltage	Analog	6	D(15:4)
7	Highest Cell Voltage	Analog	7	D(15:4)
8	Message Count	Analog	8	D(15:0)

Additional Commands

Data Load Command

1553B receive commands consist of 2 data words to the sub-address specified in Table V. Only the first data word is used.

Table V – Commands

Item	Function Title	Sub-Address	1 st Data Word of 1553B Receive Command (Hex)
1	Reset OVP Latch	15	0400

Telemetry Frame Sync Command

1553B broadcast command on sub-address 17 (any data word) commands the 8637-12 to refresh its RT address.

Remote Terminal State Command

1553B transmit command on sub-address 21 for one data word. The reply word will be 4000(Hex), to indicate that the unit is ready to accept another command or 5000(Hex), to indicate that the unit is busy and cannot accept another command.

1553B Data Wrap Around

Sub-address 30 is dedicated to data wrap around as specified in MIL-STD-1553B.

Supported Mode Codes

The 8637-12 supports the 1553B Mode Codes in Table VI.

Table VI – 1553B Mode Codes

Mode Code Name	Mode Code Number
Transmit Status Word	2
Transmitter Shutdown	4
Override Transmitter Shutdown	5
Reset Remote Terminal	8

1553B Status Flag Bits

The 8637-12 supports the following 1553B status flag bits:

1. Message Error bit
2. Broadcast Message Received bit

All other status bits are set to "0".

**Connector P1
26 Pin Subminiature-D Plug
Cell Sense**

Pin #	Function Name <u>1/</u>	Pin #	Function Name <u>2/</u>
23	CELL_12+	17	CELL_24+
9	CELL_11+	7	CELL_23+
3	CELL_10+	14	CELL_22+
19	CELL_9+	1	CELL_21+
10	CELL_8+	20	CELL_20+
13	CELL_7+	12	CELL_19+
16	CELL_6+	18	CELL_18+
26	CELL_5+	8	CELL_17+
5	CELL_4+	4	CELL_16+
2	CELL_3+	21	CELL_15+
15	CELL_2+	22	CELL_14+
24	CELL_1+	6	CELL_13+
11	CELL_1-	25	CELL_13-

1/ For Battery A. 2/ For Battery B.

**Connector J2 for Control Board
Connector J5 for Control Board
Triaxial
1553B Bus A**

CHA_DATA_H
CHA_DATA_L
SHIELD

**Connector J3 for Control Board
Connector J6 for Control Board
Triaxial
1553B Bus B**

CHB_DATA_H
CHB_DATA_L
SHIELD

**Connector J1 for Control Board 2/
Connector J4 for Control Board 1/
51 Pin Micro-D Receptacle
Control & Test Points**

Pin #	Function	Pin #	Function	Pin #	Function
1	30V_RTN	18	V_BAT_3	35	V_BAT_2
2	NC_ISOLATION	19	NC_ISOLATION	36	NC_ISOLATION
3	NC_ISOLATION	20	+30V_POWER	37	NC_ISOLATION
4	NC_ISOLATION	21	+30V_POWER	38	NC_ISOLATION
5	30V_RTN	22	NC_ISOLATION	39	SPARE
6	NC_ISOLATION	23	NC_ISOLATION	40	CHASSIS GND
7	CHASSIS GND	24	CHASSIS GND	41	CELL_CHG_24
8	CELL_CHG_12	25	LOW_CELL	42	SPARE
9	SPARE	26	RESERVED	43	BEU_ON_CMD_1
10	BEU_OFF_CMD_2	27	BAL_ON_1	44	BEU_ON_CMD_2
11	BEU_OFF_CMD_1	28	BAL_ON_2	45	HIGH_CELL
12	RTA_2	29	RTA_0	46	RTA_4
13	RTA_GND	30	RTA_GND	47	RTA_GND
14	RTA_GND	31	RTA_GND	48	RTA_GND
15	RTA_1	32	RTA_3	49	RTPTY
16	OV_PROT	33	V_BAT_TP	50	V_BAT_RTN1
17	V_BAT_RTN3	34	V_BAT_RTN2	51	V_BAT_1

1/ For Battery A. 2/ For Battery B.

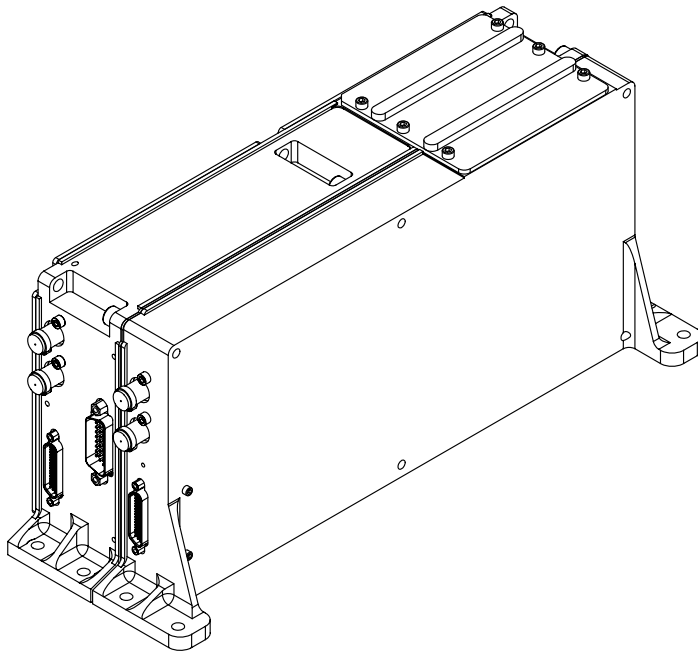

3D View

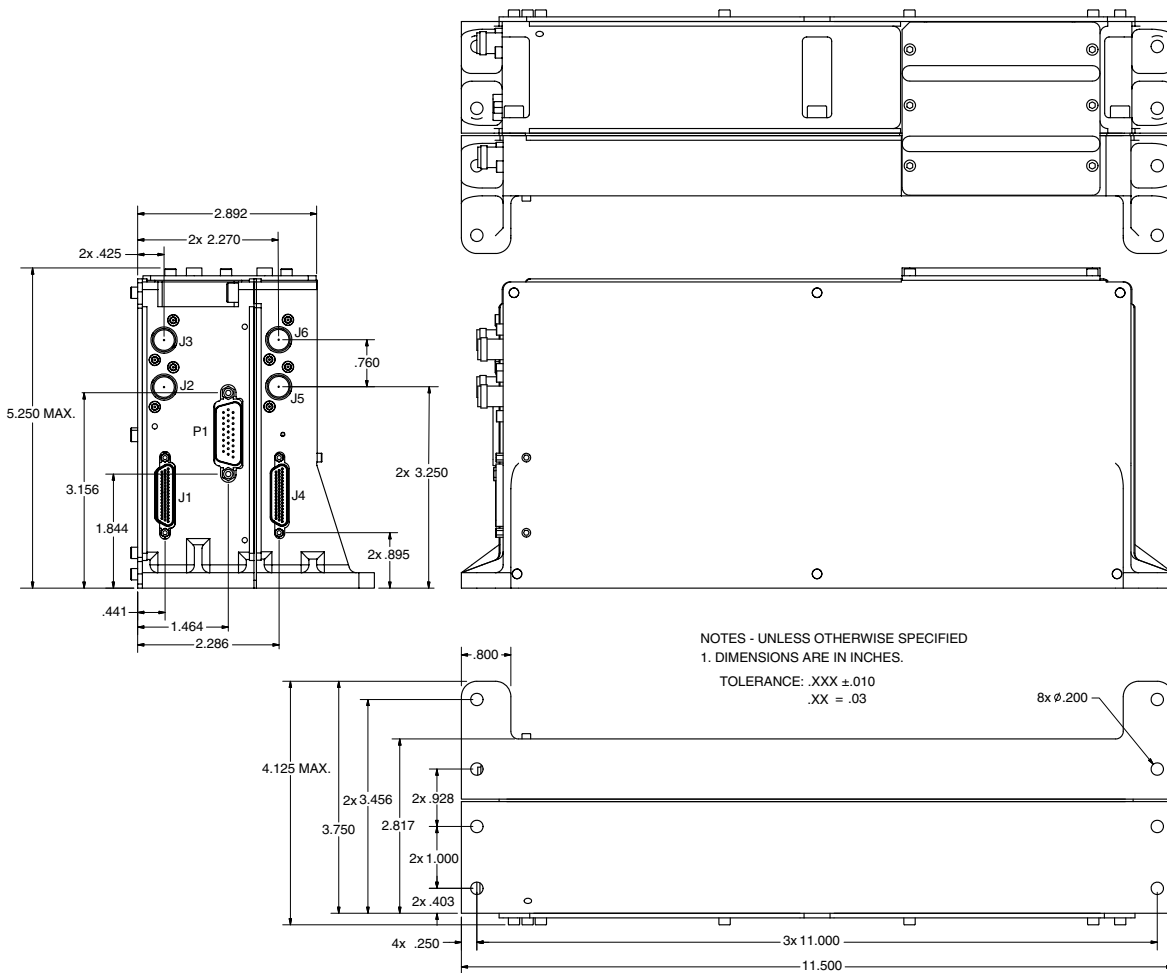

Outline

Standard Configuration

Power Dissipation

11.6 Watts from 30V Supply
1.44 Watts from battery

Operating Base Plate Temperature

BEU8637-12-S -34°C to +71°C
BEU8637-12 0°C to +70°C

Storage Temperature

-34°C to +71°C

Dimensions

11.5" L x 4.125" W x 5.250" H

Weight

5.16 lbs (2.35 kg)

Ordering Information

MODEL NUMBER	SCREENING
BEU8637-12-S	High Reliability Space Grade
BEU8637-12	Commercial Flow

EXPORT CONTROL:

This product is controlled for export under the International Traffic in Arms Regulations (ITAR). A license from the U.S. Department of State is required prior to the export of this product from the United States.

EXPORT WARNING:

Aeroflex's military and space products are controlled for export under the International Traffic in Arms Regulations (ITAR) and may not be sold or proposed or offered for sale to certain countries. (See ITAR 126.1 for complete information.)

PLAINVIEW, NEW YORK

Toll Free: 800-THE-1553
Fax: 516-694-6715

INTERNATIONAL

Tel: 805-778-9229
Fax: 805-778-1980

NORTHEAST

Tel: 603-888-3975
Fax: 603-888-4585

SE AND MID-ATLANTIC

Tel: 321-951-4164
Fax: 321-951-4254

WEST COAST

Tel: 949-362-2260
Fax: 949-362-2266

CENTRAL

Tel: 719-594-8017
Fax: 719-594-8468

www.aeroflex.com info-ams@aeroflex.com

Aeroflex Microelectronic Solutions reserves the right to change at any time without notice the specifications, design, function, or form of its products described herein. All parameters must be validated for each customer's application by engineering. No liability is assumed as a result of use of this product. No patent licenses are implied.



Our passion for performance is defined by three attributes represented by these three icons: solution-minded, performance-driven and customer-focused