

THE INFORMATION CONTAINED HEREIN IS CONSIDERED "PROPRIETARY" TO BEL FUSE INC. AND SHALL NOT BE COPIED, REPRODUCED OR DISCLOSED WITHOUT THE WRITTEN APPROVAL OF BEL FUSE INC.

RoHS
2002/95/EC



ELECTRICAL CHARACTERISTICS @ 25°C

URNS RATIO

| | |
|-----|---------------|
| TP1 | 1CT : 1CT ±2% |
| TP2 | 1CT : 1CT ±2% |
| TP3 | 1CT : 1CT ±2% |
| TP4 | 1CT : 1CT ±2% |

OCL @ 100kHz/100mVRMS

| | |
|-------------|------------|
| 8mA DC BIAS | 350µH MIN. |
|-------------|------------|

INS. LOSS

| | |
|------------------|-------------|
| 0.1MHz TO 1MHz | -1.1 dB MAX |
| 1MHz TO 65MHz | -0.5 dB MAX |
| 65MHz TO 100MHz | -0.8 dB MAX |
| 100MHz TO 125MHz | -1.2 dB MAX |

RET. LOSS (MIN)

| | |
|--------------|-----------------------|
| 0.5MHz-40MHz | -18 dB |
| 40MHz-100MHz | -12+20LOG(f/80MHz) dB |

CM TO CM REJ

| | |
|-----------------|------------|
| 100kHz - 100MHz | -30 dB MIN |
|-----------------|------------|

CM TO DM REJ

| | |
|-----------------|------------|
| 100kHz - 100MHz | -35 dB MIN |
|-----------------|------------|

HIPOT (Isolation Voltage):

1500 Vrms or 2250VDC

SCHEMATIC

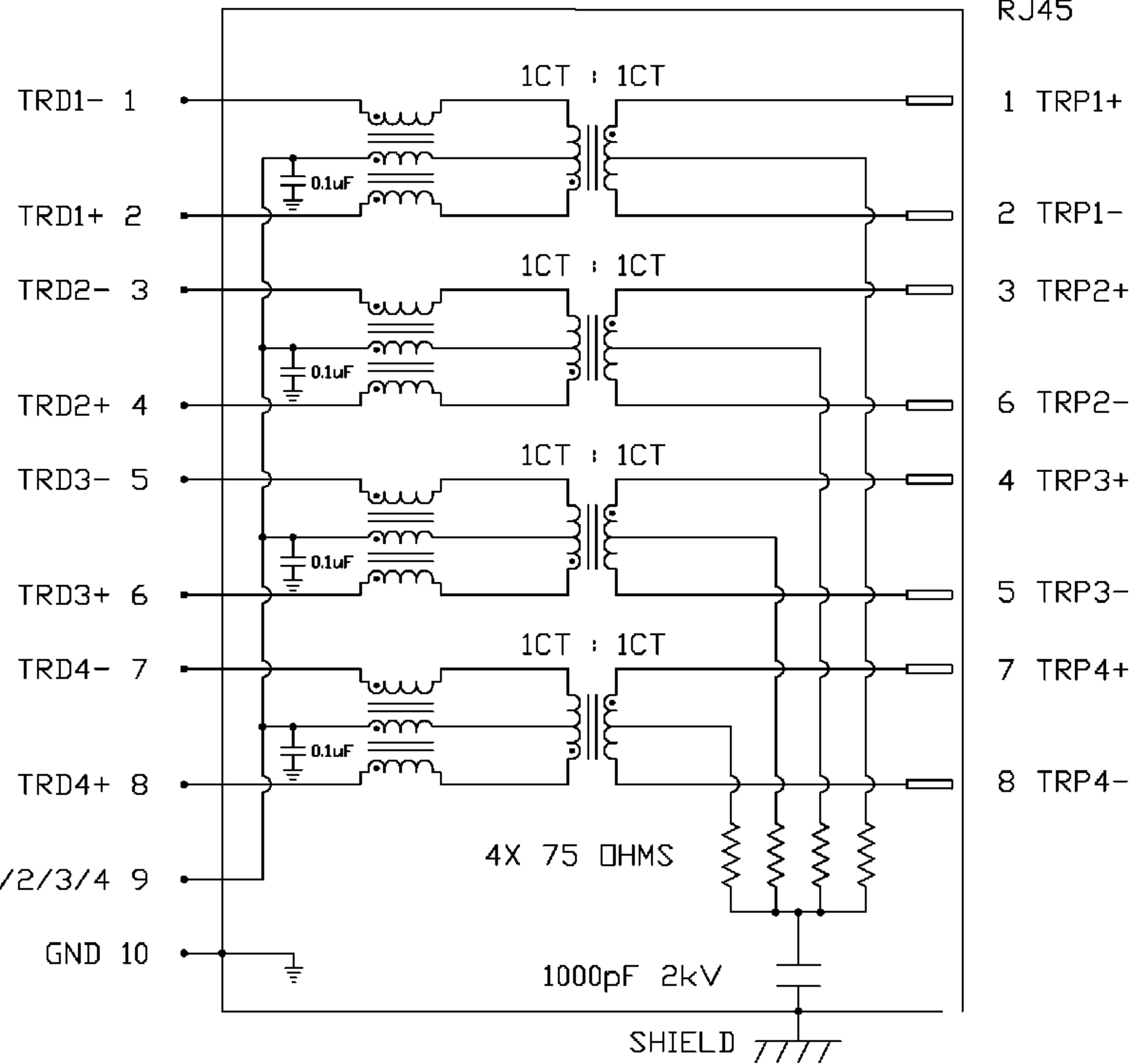

RJ45

- 1 TRP1+
- 2 TRP1-
- 3 TRP2+
- 6 TRP2-
- 4 TRP3+
- 5 TRP3-
- 7 TRP4+
- 8 TRP4-

| | | | | | | | |
|------------------------|------------------|--|--|--|---|-----------------------------------|--|
| ORIGINATED BY CHUNG | DATE 11-02-06 | TITLE 2X8 gigabit MagJack® (8 Cores) | PART NO. / DRAWING NO. 08332X8R54-F | STANDARD DIM. TOL. IN INCH .X .XX .XXX | [] METRIC DIM. AS REFERENCE UNIT : INCH [mm] SCALE : N/A | REV. : A SIZE : A4 PAGE : 2 | <p>COMPONENTS FOR A CONNECTED PLANET</p> |
| DRAWN BY DE | DATE 11-02-06 | TITLE 0833-2X8R-54-F | FILE NAME 08332X8R54-FA.DWG | | | | |

THE INFORMATION CONTAINED HEREIN IS CONSIDERED "PROPRIETARY" TO BEL FUSE INC. AND SHALL NOT BE COPIED, REPRODUCED OR DISCLOSED WITHOUT THE WRITTEN APPROVAL OF BEL FUSE INC.

RoHS
2002/95/EC

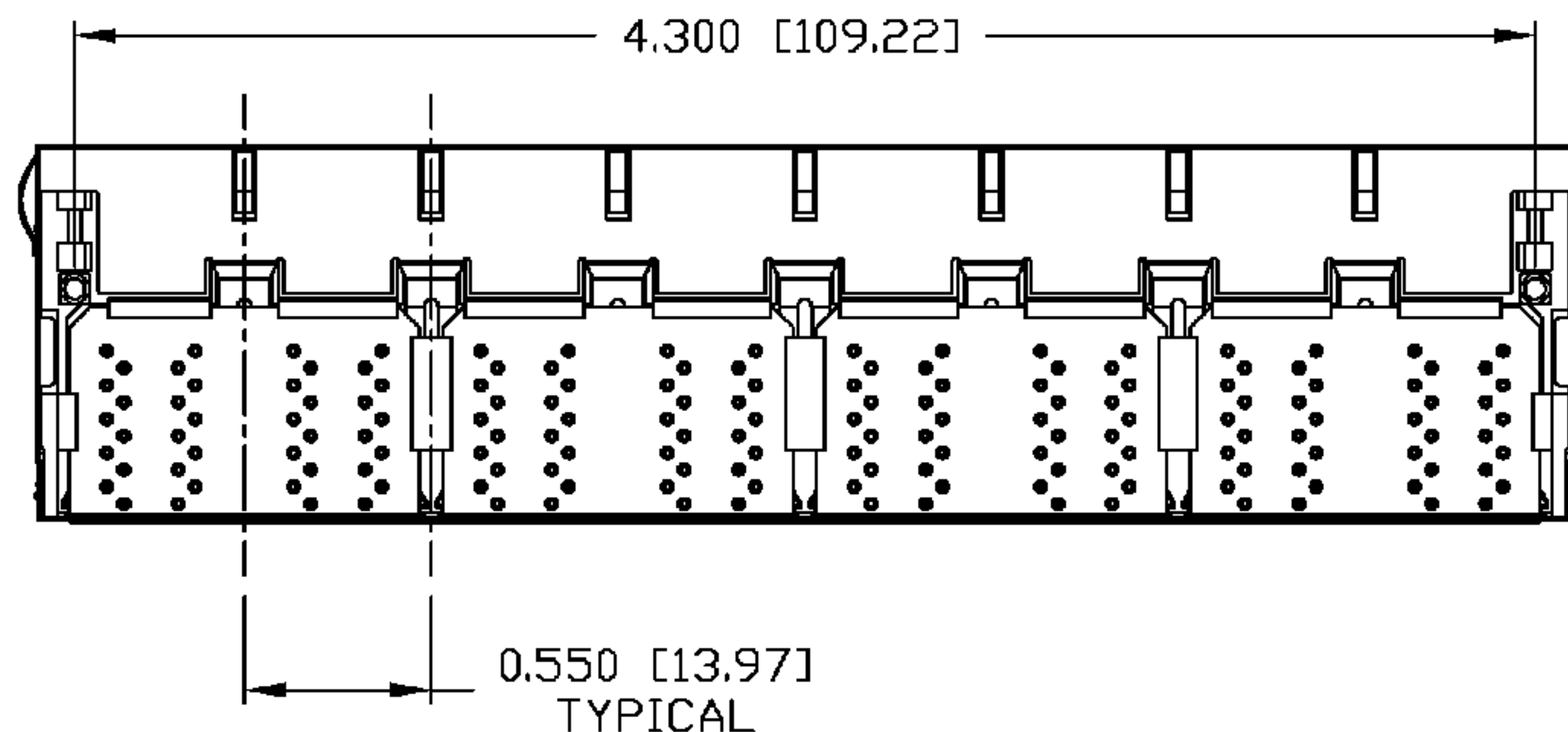
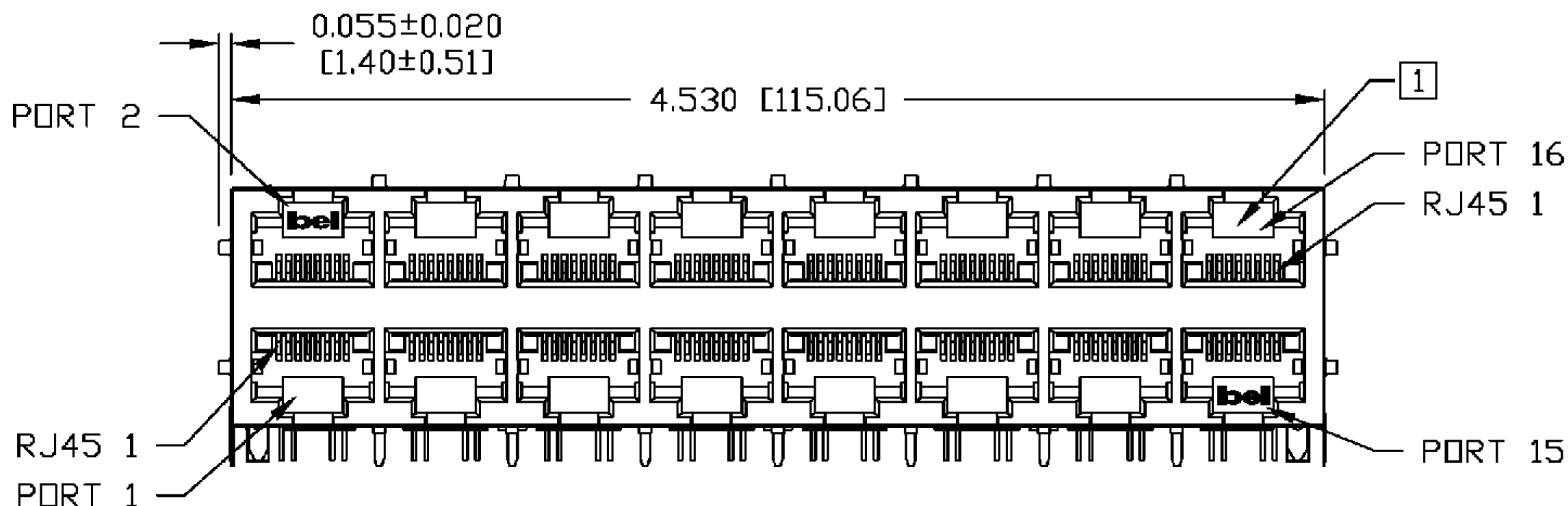
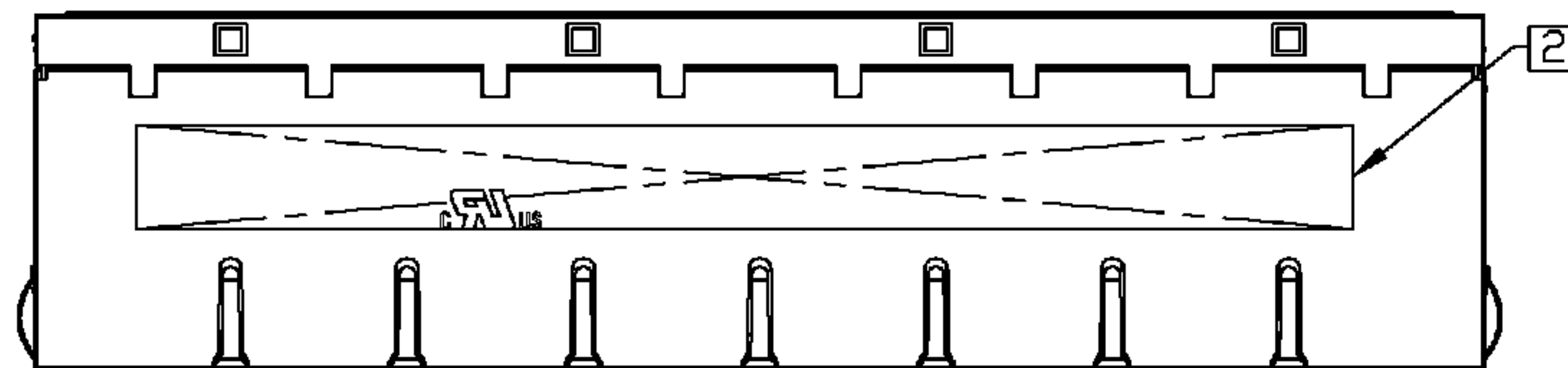
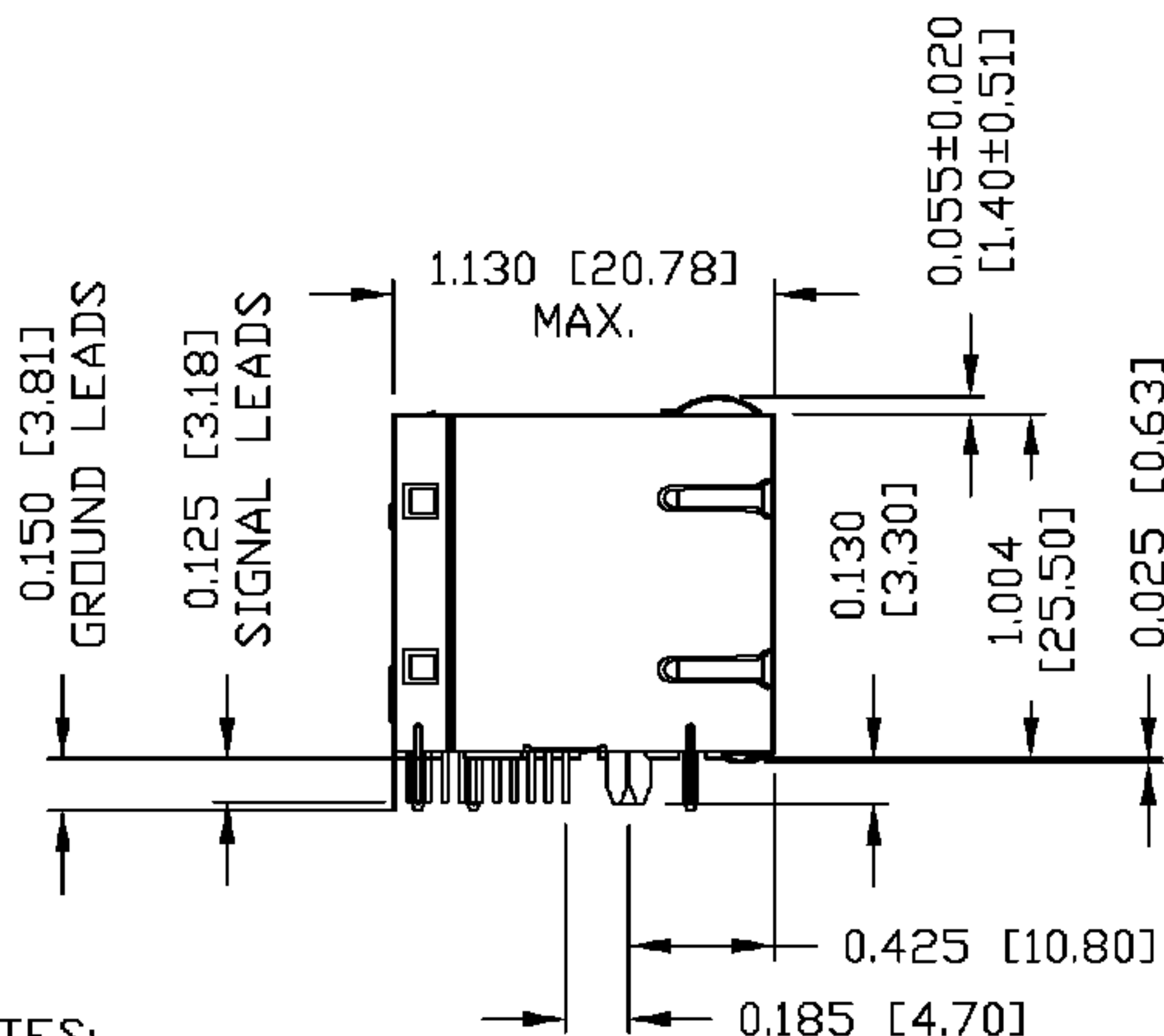

NOTES:

- PLASTIC HOUSING: THERMOPLASTIC PBT
FLAMMABILITY RATING UL 94V-0
- CONTACT PLATING: 50 MICRO-INCH HARD GOLD PLATING
- OUTPUT PINS: TIN-COATED COPPER WIRE, DIA 0.018 INCH.
- METAL SHIELD: NICKEL PLATED ON COPPER ALLOY.
(ALL GROUND LEADS ARE SOLDER DIPPED)

1. JACK CAVITY CONFORMS TO FCC RULES AND REGULATIONS, PART 68 SUBPART F.
2. MARK PART WITH MFG LOGO, MFG NAME, PART NUMBER, AND DATE CODE.

- UL RECOGNIZED - FILE #E196366 AND E169987.
- 3. RoHS COMPLIANCE, PER EU DIRECTIVE 2002/95/EC.

| | | | | | | |
|---------------------------|------------------|--|--|-------------------------------|-----------------------------------|---|
| ORIGINATED BY QIN/BILL | DATE 11-02-06 | TITLE 2X8 gigabit MagJack® (8 Cores) | PART NO. / DRAWING NO. 08332X8R54-F | STANDARD DIM. TOL. IN INCH | [] METRIC DIM. AS REFERENCE | <p>COMPONENTS ON A CONNECTED PLANET</p> |
| DRAWN BY TING | DATE 11-02-06 | 0833-2X8R-54-F | FILE NAME 08332X8R54-FA.DWG | .X | UNIT : INCH [mm] | |
| | | | | .XX | SCALE : N/A | |
| | | | | .XXX ±0.010 | REV. : A SIZE : A4 PAGE : 3 | |

THE INFORMATION CONTAINED HEREIN IS CONSIDERED "PROPRIETARY" TO BEL FUSE INC. AND SHALL NOT BE COPIED, REPRODUCED OR DISCLOSED WITHOUT THE WRITTEN APPROVAL OF BEL FUSE INC.

RoHS
2002/95/EC

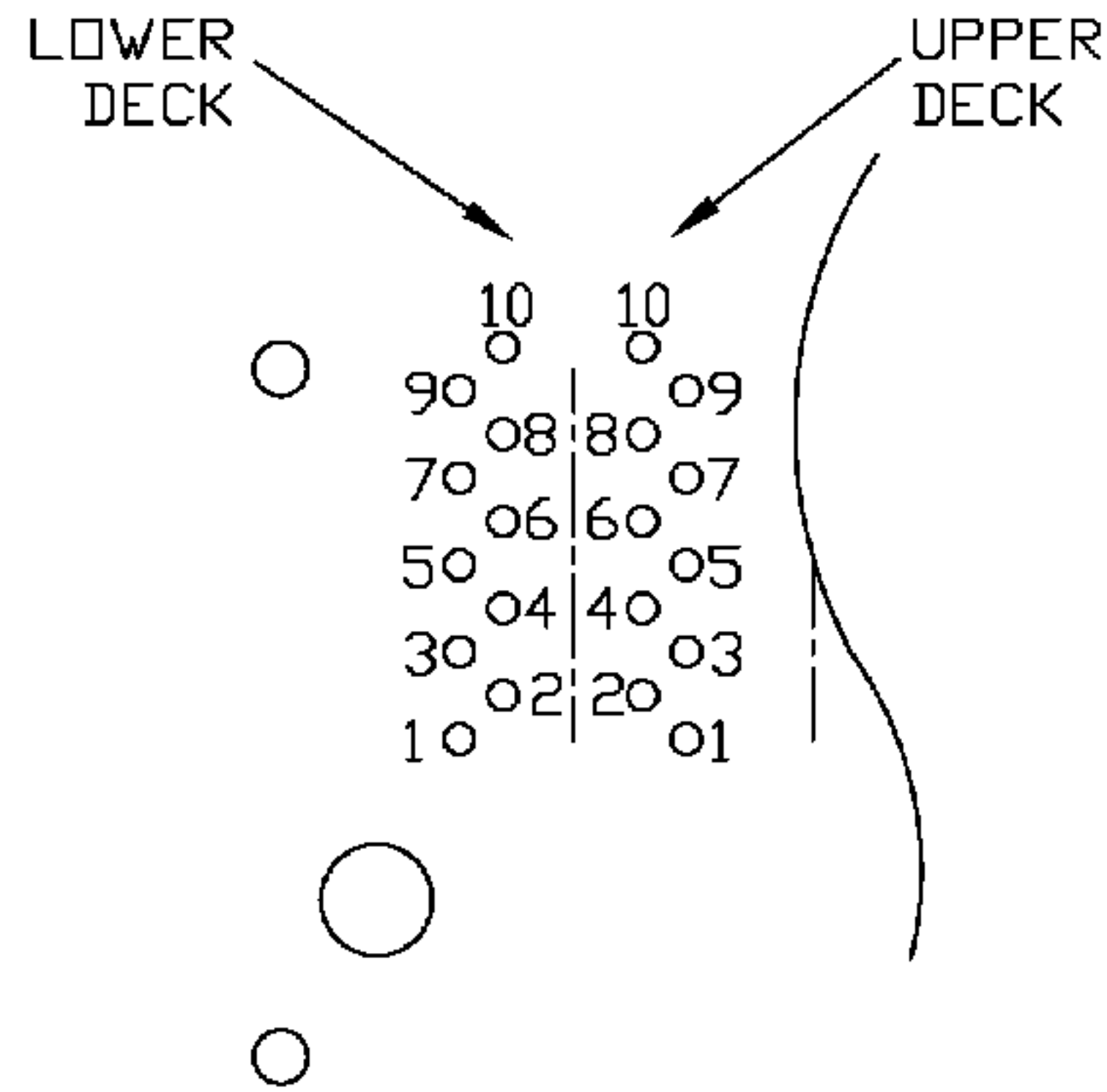

PIN-OUT INFORMATION
(COMPONENT SIDE VIEW)

| | |
|----|-------------|
| 10 | GND |
| 9 | TRCT1/2/3/4 |
| 8 | TRD 4+ |
| 7 | TRD 4- |
| 6 | TRD 3+ |
| 5 | TRD 3- |
| 4 | TRD 2+ |
| 3 | TRD 2- |
| 2 | TRD 1+ |
| 1 | TRD 1- |

PORT ASSIGNMENT
(COMPONENT SIDE VIEW)

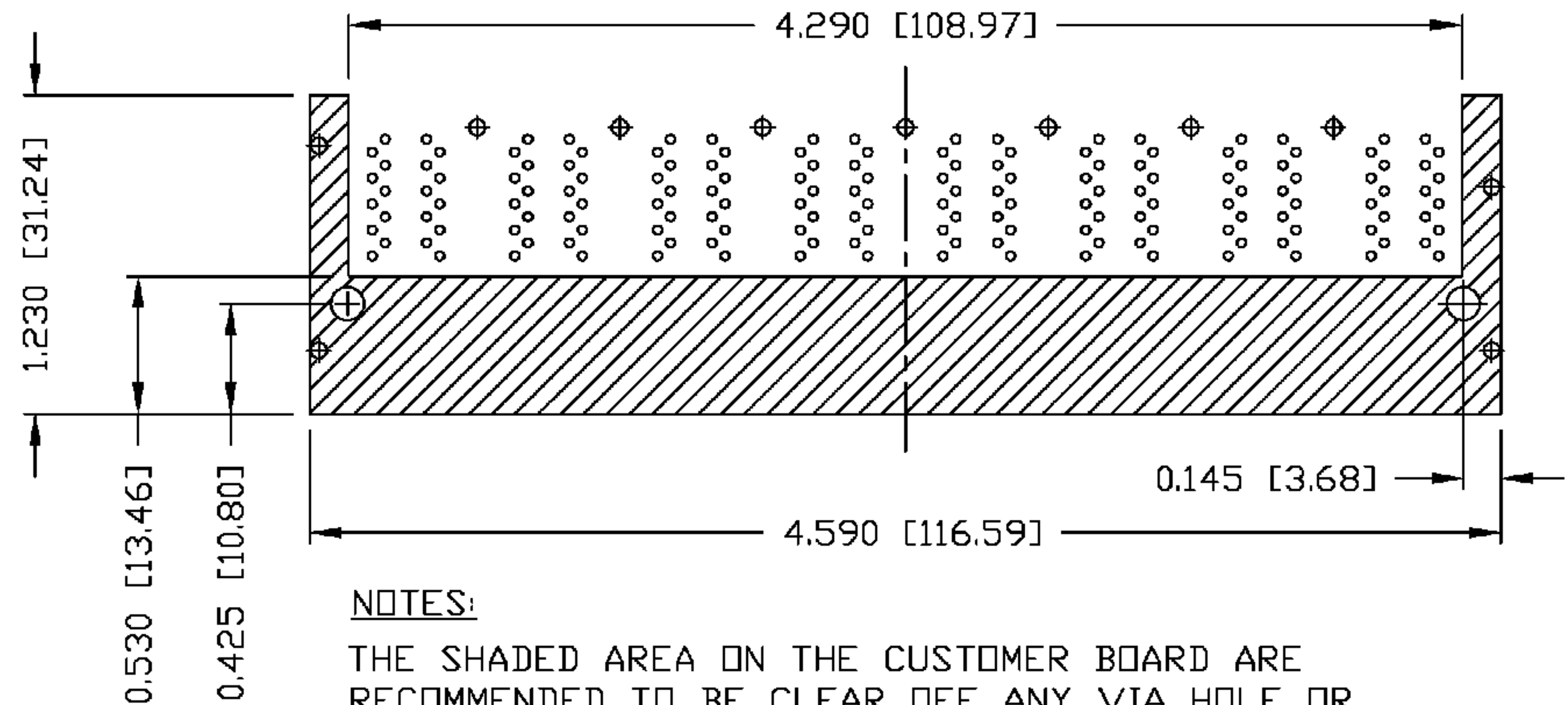
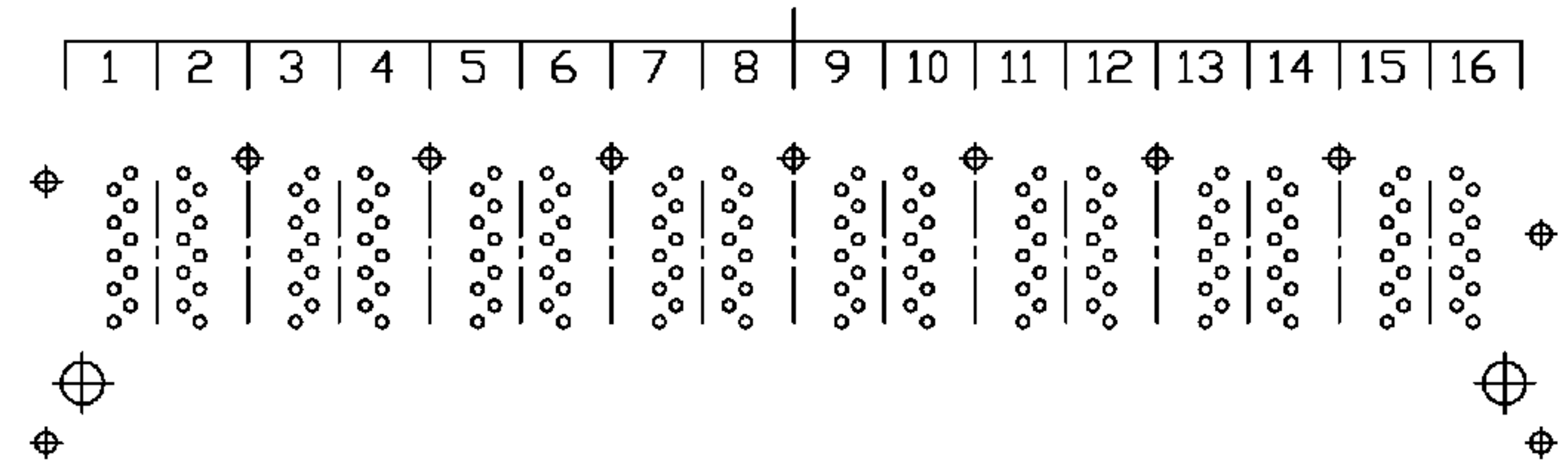

NOTES:

THE SHADED AREA ON THE CUSTOMER BOARD ARE RECOMMENDED TO BE CLEAR OFF ANY VIA HOLE OR COMPONENT PAD.

| | | | | | | |
|---------------------------|------------------|--|--|---|--|---|
| ORIGINATED BY QIN/BILL | DATE 11-02-06 | TITLE 2X8 gigabit MagJack® (8 Cores) 0833-2X8R-54-F | PART NO. / DRAWING NO. 08332X8R54-F | STANDARD DIM. TOL. IN INCH .X .XX .XXX ±0.004 | [] METRIC DIM. AS REFERENCE UNIT : INCH [mm] SCALE : N/A REV. : A SIZE : A4 PAGE : 4 | bel COMPONENTS FOR A CONNECTED PLANET |
| DRAWN BY TING | DATE 11-02-06 | FILE NAME 08332X8R54-FA.DWG | | | | |

THE INFORMATION CONTAINED HEREIN IS CONSIDERED "PROPRIETARY" TO BEL FUSE INC. AND SHALL NOT BE COPIED, REPRODUCED OR DISCLOSED WITHOUT THE WRITTEN APPROVAL OF BEL FUSE INC.

RoHS
2002/95/EC

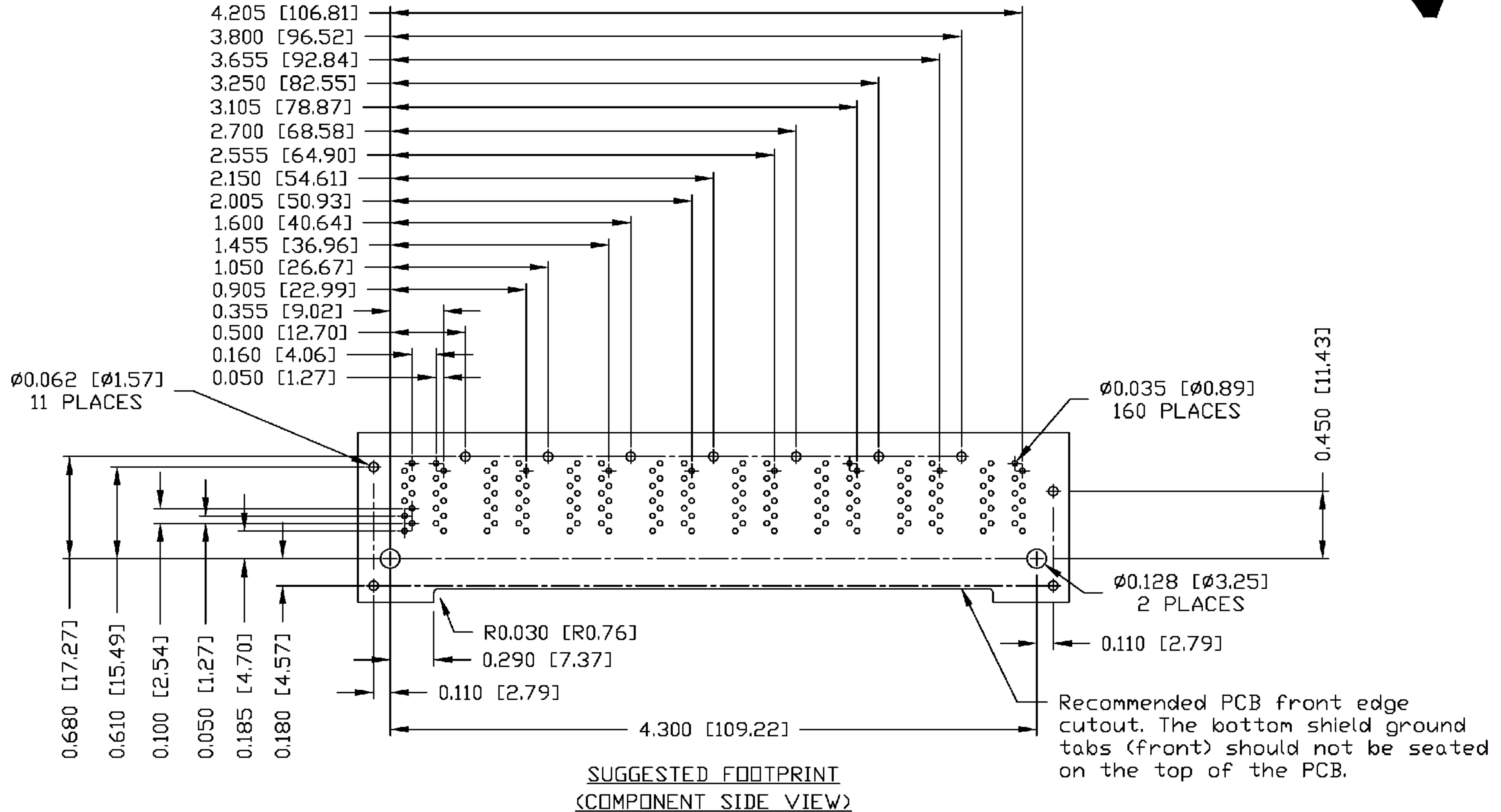

| | | | | | | | | |
|---------------------------|------------------|--|--|--------------------------------|-------------------------------|---|---------------------------------|-----------------------------------|
| ORIGINATED BY QIN/BILL | DATE 11-02-06 | TITLE 2X8 gigabit MagJack® (8 Cores) 0833-2X8R-54-F | PART NO. / DRAWING NO. 08332X8R54-F | | STANDARD DIM. TOL. IN INCH | | [] METRIC DIM. AS REFERENCE | |
| | DRAWN BY TING | | DATE 11-02-06 | FILE NAME 08332X8R54-FA.DWG | .X .XX .XXX | ∅ | UNIT : INCH [mm] SCALE : N/A | REV. : A SIZE : A4 PAGE : 5 |



THE INFORMATION CONTAINED HEREIN IS CONSIDERED "PROPRIETARY" TO BEL FUSE INC. AND SHALL NOT BE COPIED, REPRODUCED OR DISCLOSED WITHOUT THE WRITTEN APPROVAL OF BEL FUSE INC.

RoHS
2002/95/EC



SUGGESTED PANEL OPENING

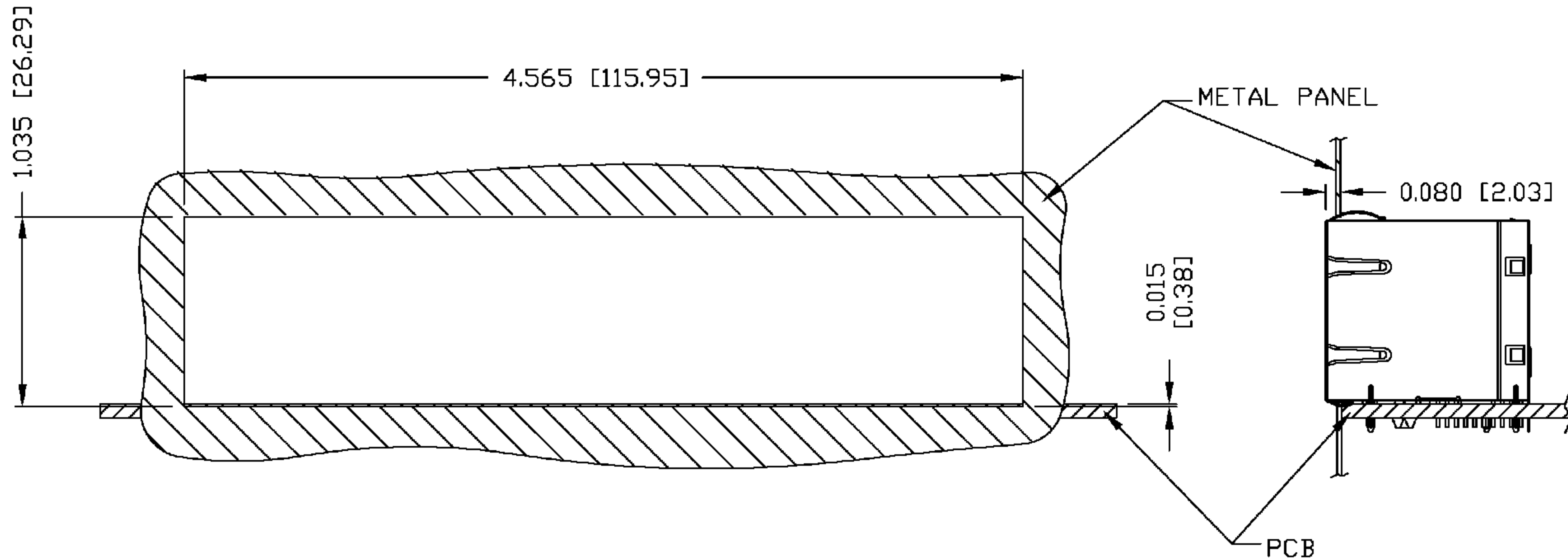

NOTE:

THE DISTANCE OF PANEL INSIDE SURFACE RELATIVE TO FRONT SURFACE OF PART IS ONLY A SUGGESTION. IN CASE THIS DISTANCE IS DIFFERENT, THE REQUIRED PANEL OPENING DIMENSIONS CHANGE ACCORDINGLY.

PACKING INFORMATION

PACKING TRAY : 0200-9999-B2 (TOP)
0200-9999-B1 (BOTTOM)

PACKING QUANTITY : 10 PCS FINISHED GOODS PER TRAY
7 TRAYS (70 PCS FINISHED GOODS) PER CARTON BOX

NOTE : CARDBOARDS ARE PLACED BETWEEN LAYERS OF PACKING TRAY INSIDE CARTON BOX
(INCLUDE THE UPPERMOST AND LOWERMOST TRAY)

| | | | | | | | | |
|---------------------------|------------------|--|--|---------------|------------------|------------------------------|-----------|----------------------------|
| ORIGINATED BY QIN/BILL | DATE 11-02-06 | TITLE 2X8 gigabit MagJack® (8 Cores) 0833-2X8R-54-F | PART NO. / DRAWING NO. 08332X8R54-F | STANDARD DIM. | | [] METRIC DIM. AS REFERENCE | | COMPONENTS-OR-A-PLANET |
| | | | | TOL. IN INCH | UNIT : INCH [mm] | REV. : A | | |
| DRAWN BY TING | DATE 11-02-06 | | FILE NAME 08332X8R54-FA.DWG | .X | | SCALE : N/A | SIZE : A4 | |
| | | | | .XX | | | PAGE : 6 | |
| | | | | .XXX | ±0.004 | | | |