

Models 7004A & 7005A

PLANAR CROWN® UNIVERSAL CONNECTOR SYSTEM dc to 40.0 GHz

SMA; Type N; TNC; GPC-7; 3.5mm; SMK; 2.4mm

AEROFLEX
A passion for performance.



 **RoHS**

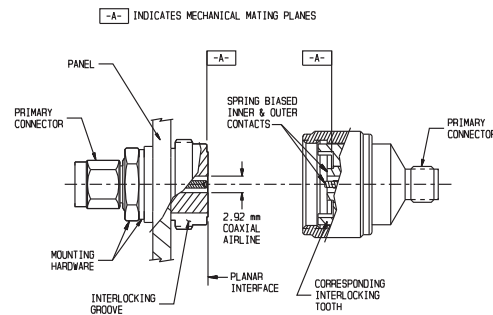

Features

The use of **PLANAR CROWN®** connectors on instruments, cables, components/accessories offers the manufacturer and user the following benefits.

Reduced Downtime - Damaged connectors can be replaced in seconds without any tools. Repair cost is minimized to that of a single connector. Recalibration, in most applications, is virtually eliminated due to closely matched phase, mechanical dimensions and insertion loss of the replaceable **PLANAR CROWN®** assemblies.

Versatility - Ability to select different connector types adds versatility to instruments, cables, systems and accessories. It offers the end user multiple connector options. Connector type and sex can be readily interchanged as dictated by the system/DUT, eliminating the need for adapters.

Superior Electrical Performance than would be obtained by additional adapters.

Simplified Network and Power Measurements on non-insertable devices.

Non-rotational Interface - Since the **PLANAR INTERFACE** has interlocking teeth, it eliminates unthreading of the connection when the Crown is subjected to a rotational torque. This feature is especially useful on coaxial cables where one end unthreads so easily when the cable is subjected to twisting or flexing.

Torque Independent Connection - A torque wrench is not required when mating the Crown to the bulkhead. A reasonable hand tightening of the coupling nut results in an excellent RF connection. This is achieved by having spring biased inner and outer contacts in the Crown connectors. Spring biasing ensures an intimate electrical contact at the **PLANAR INTERFACE**. A pilot diameter on the bulkhead guarantees excellent concentricity.

Axial Isolation of the Center Contact - Any excessive axial force on the Crown center contact is absorbed by the spring biasing at the Planar interface end.

Standardized Mounting Holes - All instrument panels can be fabricated with a standard 3/8" Dia. D-hole independent of the front panel connector type/sex. This eliminates changes in sheet metal design when different connector options are requested.

Description

The **PLANAR CROWN® UNIVERSAL CONNECTOR SYSTEM** is comprised of two connector halves/subassemblies which have a common mating interface referred to as the **PLANAR INTERFACE**. The first connector half is called the **PLANAR BULKHEAD** which readily mounts into instrument front panels, components and cables. One end of this bulkhead has a 2.92mm (SMK) male/female primary connector. The other end has a combination of grooves, external threads and a coaxial **PLANAR INTERFACE** with a 2.92mm (SMK) airline geometry. The bulkhead operates mode free beyond 40 GHz. The second connector half, called the **PLANAR CROWN®**, has a similar 2.92mm **PLANAR INTERFACE** on one end, with spring biased inner and outer contacts. It has corresponding projections which interlock with slots on the bulkhead and a coupling nut which secures the two connector halves, resulting in a non-rotational, torque independent electrical connection. The spring biased inner and outer contacts eliminate the need for specifying proof torque and no tools are required to mate or unmate or break the connection. The primary end of the **PLANAR CROWN®** is offered in a variety of primary coaxial connector configurations such as SMA, Type N, GPC-7, TNC, 3.5mm, 2.92mm (SMK) and 2.4mm (under development), thus providing an extremely versatile connector system wherein a connector can be replaced in a matter of seconds.

EXPRESS Shipment available via 800-542-4457 or www.argosysales.com. Check with distributor for current product stocking quantities.

AEROFLEX
WEINSCHEL

Specifications



PLANAR BULKHEAD CONNECTORS

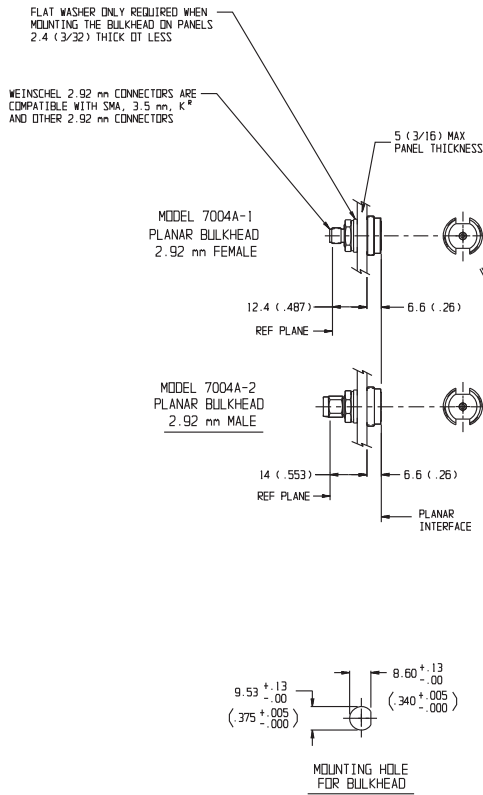

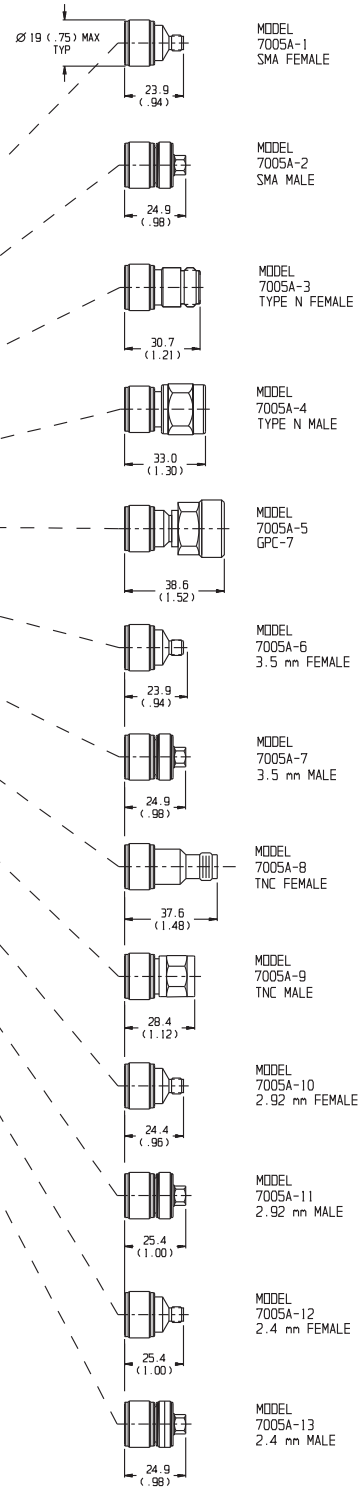

PLANAR CROWN CONNECTORS















U.S. Patent No. 4,836,801
(Other U.S. and Foreign Patents pending)

- NOTES: 1. All dimensions are given in mm (inches) and are nominal, unless otherwise specified.
2. K[®] is a registered trademark of the Wiltron 2.92mm connector
3. Unit available with RoHS compliant materials, specify when ordering.

PLANAR BULKHEAD Connectors . . . dc to 40.0 GHz

Model Number/ Primary Conn.	Frequency Range (GHz)	SWR* (maximum)	Insertion Loss * (dB maximum)	Electrical Length	
★ 7004A-1 2.92mm Female	dc - 40	----	----	19.9 ± 0.25mm	
★ 7004A-2 2.92mm Male	dc - 40	----	----	21.6 ± 0.25mm	
7010-1 2.92mm Female with dc Block	dc - 26.5	1.20-1.25	0.6-0.9	19.9 ± 0.25mm	
7010-2 2.92mm Male with dc Block	dc - 26.5	1.20-1.25	0.6-0.9	21.6 ± 0.25mm	

PLANAR CROWN Connectors . . . dc to 40.0 GHz

Model Number/ Primary Conn.	Frequency Range (GHz)	SWR* (maximum)	Insertion Loss * (dB maximum)	Electrical Length	
7005A-1 SMA Female	dc - 26.5	1.20 (dc -18 GHz) 1.25 (18 - 26.5 GHz)	0.25 (dc -18 GHz) 0.35 (18 - 26.5 GHz)	18.6 ± 0.25mm	
7005A-2 SMA Male	dc - 26.5	1.20 (dc -18 GHz) 1.25 (18 - 26.5 GHz)	0.25 (dc -18 GHz) 0.35 (18 - 26.5 GHz)	18.6 ± 0.25mm	
★ 7005A-3 Type N Female	dc - 18	1.20	0.25	18.6 ± 0.25mm	
★ 7005A-4 Type N Male	dc - 18	1.20	0.25	28.6 ± 0.25mm	
7005A-5 GPC-7	dc - 18	1.20	0.25	34.8 ± 0.25mm	
★ 7005A-6 3.5mm Female	dc - 34	1.20 (dc -18 GHz) 1.25 (18 - 26.5 GHz) 1.30 (26.5 - 34 GHz)	0.25 (dc -18 GHz) 0.35 (18 - 34 GHz)	18.0 ± 0.20mm	
★ 7005A-7 3.5mm Male	dc - 34	1.20 (dc -18 GHz) 1.25 (18 - 26.5 GHz) 1.30 (26.5 - 34 GHz)	0.25 (dc -18 GHz) 0.35 (18 - 34 GHz)	18.0 ± 0.20mm	
★ 7005A-8 TNC Female	dc - 18	1.20	0.25	26.3 ± 0.35mm	
7005A-9 TNC Male	dc - 18	1.20	0.25	26.3 ± 0.35mm	
★ 7005A-10 2.92mm Female	dc - 40	1.20 (dc -18 GHz) 1.25 (18 - 26.5 GHz) 1.35 (26.5 - 40 GHz)	0.25 (dc -18 GHz) 0.35 (18 - 26.5 GHz) 0.45 (26.5 - 40 GHz)	18.0 ± 0.15mm	
7005A-11 2.92mm Male	dc - 40	1.20 (dc -18 GHz) 1.25 (18 - 26.5 GHz) 1.35 (26.5 - 40 GHz)	0.25 (dc -18 GHz) 0.35 (18 - 26.5 GHz) 0.45 (26.5 - 40 GHz)	18.0 ± 0.15mm	
7005A-12 2.4mm Female	dc - 40	1.20 (dc -18 GHz) 1.25 (18 - 26.5 GHz) 1.35 (26.5 - 40 GHz)	0.25 (dc -18 GHz) 0.35 (18 - 26.5 GHz) 0.45 (26.5 - 40 GHz)	18.0 ± 0.15mm	
7005A-13 2.4mm Male	dc - 40	1.20 (dc -18 GHz) 1.25 (18 - 26.5 GHz) 1.35 (26.5-40 GHz)	0.25 (dc -18 GHz) 0.35 (18 - 26.5 GHz) 0.45 (26.5-40 GHz)	18.0 ± 0.15mm	

Notes: 1. Specifications based on mated pair of **7004A-X** and **7005A-XX**. Refer to mating PLANAR CROWN for SWR and Insertion loss specifications.
2. Aeroflex / Weinschel 2.92mm connectors are compatible with SMA, 3.5mm, SMK and other 2.92mm connectors.

General Specifications

PLANAR INTERFACE REPEATABILITY¹:

Reflection Coefficient (Magnitude):

- 60 dB (dc - 18 GHz)
- 50 dB (18 - 26.5 GHz)
- 45 dB (26.5 - 40 GHz)

Transmission (Magnitude)²:

- 40 dB (dc - 18 GHz)
- 35 dB (18 - 26.5 GHz)
- 30 dB (26.5 - 40 GHz)

Transmission (phase)²: 0.5°

1. The Repeatability specifications apply to ten consecutive disconnections and reconnections of the PLANAR INTERFACE.
2. Transmission repeatability includes the repeatability of the VNA test cable.

OPERATING TEMPERATURE: 0°C to 85°C

CONSTRUCTION: Passivated stainless steel bodies and coupling nuts. Gold plated beryllium copper contacts.

INTERFACE DIMENSIONS & ADDITIONAL FEATURES OF PRIMARY CONNECTORS:

SMA (Models 7005A-1 and -2):

Contact Pin Recession: 0 to 0.1mm (0 to 0.004 in)

Front Insulator Recession: 0.23 to 0.33mm (0.009 to 0.013 in)

Aeroflex / Weinschel high frequency **SMA** connector operates mode free beyond 26.5 GHz and is a superior SMA connector. It incorporates a wider shoulder on the male and female mating planes (0.020" typical compared to 0.007" on standard SMA connectors) and has a 3 slot female contact instead of the conventional four slot design. Both these features result in a **more rugged** connector with longer life and improved repeatability. Unlike many commercial teflon loaded SMA connectors, these connectors will not cause premature damage when mated with 3.5mm, 2.92mm and K[®] connectors.

Type N (Models 7005A-3 and -4):

Contact Pin Protrusion (N female): 5.18 to 5.26mm (0.204 to 0.207 in)

Contact Pin Recession (N Male): 5.28 to 5.36mm (0.208 to 0.211 in)

The male and female Type N connectors are Precision Test connectors per MIL-STD-348. They are usable to 22 GHz.

GPC-7 (Model 7005A-5):

Contact Pin Recession: 0 to 0.05mm (0 to 0.002 in)

The GPC-7 connectors are designed per IEEE Std 287.

3.5mm (Models 7005A-6 and -7):

Contact Pin Recession: 0 to 0.08mm (0 to 0.003 in)

TNC (Models 7005A-8 and -9):

Contact Pin and Insulator Protrusion (TNC Female): 5.03 to 5.28mm (0.198 to 0.208 inch)

Contact Pin and Insulator Recession: 5.28mm (0.208 in) minimum

These TNC male and female connectors are designed per MIL-STD-348 interface requirements for the NEW TNC connectors and operate mode free beyond 18 GHz.

2.92mm (Models 7005A-10 and -11):

Contact Pin Recession: 0 to 0.08mm (0 to 0.003 in)

In addition to the many advantages of 2.92mm airline connectors the Aeroflex / Weinschel version incorporates a three slot female contact design resulting in a more ruggedized contact than the conventional four slot design on most 2.92mm connectors.

2.4mm (Models 7005A-12 and 7005A-13):

Contact Pin Recession: 0 to 0.08mm (0 to 0.003 in)

Applications

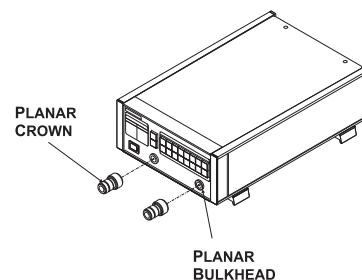

Test Instruments - Synthesizers; network/spectrum analyzers, power meters and many more.

Accessories - Detectors, SWR bridges/auto testers; power sensors, etc.,

Microwave Cables - Cables constructed with the **PLANAR BULKHEAD** connector interface at one end offer the user a wide choice of primary coaxial connectors offered on the **PLANAR CROWN** models. For an instrument such as a VNA, this eliminates the need for having different sets of test cables for different connector configurations. Cables with a built in **PLANAR CROWN** on the opposite end mate directly with **PLANAR BULKHEADS** on instruments, providing an excellent non-rotational electrical connection.

Special Configurations - The **PLANAR BULKHEAD** design can be provided with a built in attenuator or dc block. This is a useful feature when instrument front ends require a masking attenuator or need to be protected against dc voltages. Although the basic mechanical design of the **PLANAR BULKHEAD** was intended for panel mounting, it can be modified to mount directly into other accessories. The primary connector of the bulkhead can also be modified to launch directly on microstrip or suspended stripline substrates.

Model 7010 PLANAR BULKHEAD with DC Block

10 MHz to 26.5 GHz

SMK Connectors to Planar Interface



Features

- /// Usable to 40 GHz.
- /// Eliminates the requirement for a separate dc Block to protect instrument front ends.
- /// Offers the user multiple connector options and quick replacement of damaged connectors.
- /// Provides all the features and versatility of the PLANAR CROWN® Connector System.

Specifications

NOMINAL IMPEDANCE: 50 Ω

FREQUENCY RANGE: 10 MHz to 26.5 GHz

MAXIMUM SWR:

Frequency (GHz)	SWR
10 MHz - 18	1.20
18 - 26.5	1.25

INSERTION LOSS & REPEATABILITY (dB):

Frequency (GHz)	Loss
10 MHz - 18	0.6
18 - 26.5	0.9

Note: SWR and Insertion Loss specifications are based on a mated pair of Models 7010-X and 7005A-XX PLANAR CROWN® connector types.

DC BLOCK CAPACITOR RATING: 1,700 pf minimum;
+ 50 Vdc working voltage

SCHEMATIC DIAGRAM:

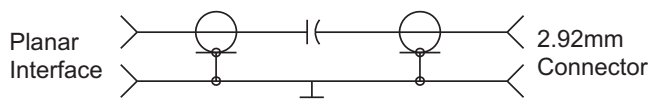

TEMPERATURE RANGE: 0°C to +60°C (operating)
-40°C to +70°C (non-operating)

CONNECTORS: Primary connector is SMK (2.92 mm) female or male connector, with a PLANAR INTERFACE on opposite end. Contact Pin Recession of SMK (2.92mm) is 0 to 0.076 mm (0 to 0.003 in) for reference plane. Add -1 for female SMK connector or -2 for SMK male connector

CONSTRUCTION: Passivated Stainless steel body and connectors; gold plated beryllium copper contacts

WEIGHT: Net: 20 g (0.7 oz)

PHYSICAL DIMENSIONS:

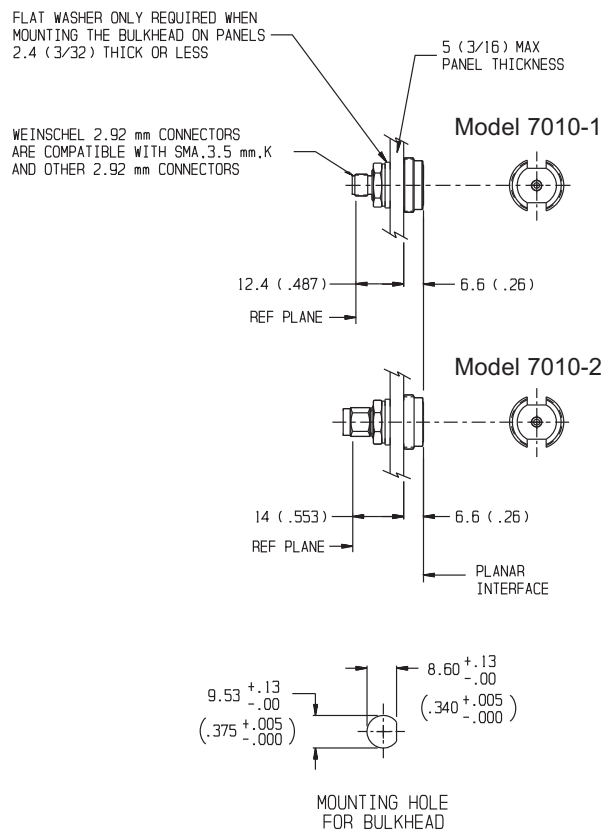

NOTE: All dimensions are given in mm (inches) and are maximum, unless otherwise specified.