

# Planar Back (Tunnel) Diodes MBD Series

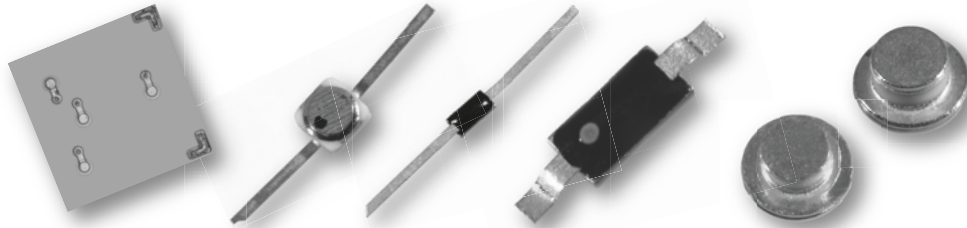

## Description

The MBD series of back (tunnel) diodes are fabricated on germanium substrates using passivated, planar construction and gold metallization for reliable operation up to +110 °C. Unlike the standard tunnel diode  $I_p$  is minimized for detector operation and offered in five nominal values with varying degrees of sensitivity and video impedance. The back detector is generally operated with zero bias and is known for its excellent temperature stability and fast video rise times.

## Features

- Zero bias operation
- Excellent temperature stability
- Low Video Impedance
- Screening per MIL-PRF-19500 and MIL-PRF-35834 available.

## Absolute Maximum Ratings

Parameters	Rating
Input Power	+14 dBm CW or Pulsed in a tuned detector
Operating Temperature	-65 °C to +110 °C
Storage Temperature	-65 °C to +125 °C
Soldering Temperature	
Chip	See chip assembly instructions on page 8
Packaged	+230 °C for 5 seconds (must be hand soldered)

## Chip

### Electrical Specifications, $T_A = 25\text{ °C}$

Model	$I_p$		$C_j$ MAX pF	$\gamma$ TYP mV / mW	$R_v$ TYP $\Omega$	$I_p / I_v$ MIN	$V_R$ MIN mV	$V_F$ MAX mV	Package
	MIN $\mu A$	MAX $\mu A$							
MBD1057-C18	100	200	0.30	1,000	180	2.5	420	135	C18
MBD2057-C18	200	300	0.30	750	130	2.5	410	130	C18
MBD3057-C18	300	400	0.30	500	80	2.5	400	125	C18
MBD4057-C18	400	500	0.30	275	65	2.5	400	120	C18
MBD5057-C18	500	600	0.30	250	60	2.5	400	110	C18
Test Conditions			$V_R = V_V$ $F = 100\text{ MHz}$	$P_{IN} = -20\text{ dBm}$ $R_L = 10\text{ K}\Omega$ $F = 10\text{ GHz}$			$I_R = 500\text{ }\mu A$	$I_F = 3\text{ mA}$	



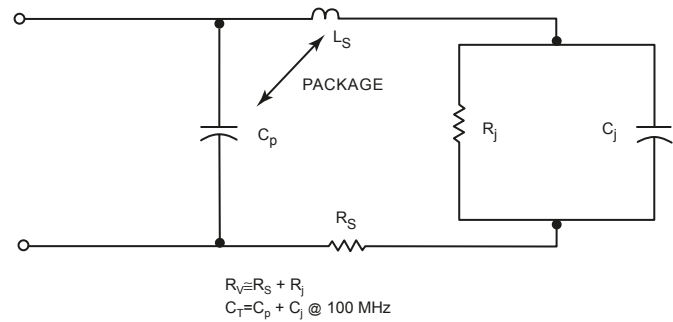
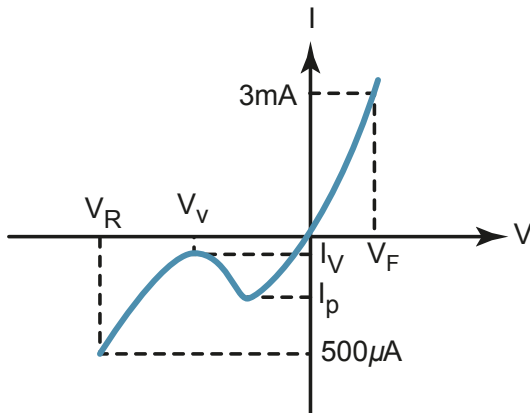

## Package Electrical Specifications, $T_A = 25^\circ\text{C}$

Model	$I_p$		$C_T$	$\gamma$ TYP mV / mW	$R_V$ TYP $\Omega$	$I_p / I_V$ MIN	$V_R$ MIN mV	$V_F$ MAX mV	Package
	MIN $\mu\text{A}$	MAX $\mu\text{A}$	MAX pF						
MBD1057-E28 / 28X	100	200	0.40	1,000	180	2.5	420	135	E28 / 28X
MBD1057-H20	100	200	0.50	1,000	180	2.5	420	135	H20
MBD1057-T54	100	200	0.55	1,000	180	2.5	420	135	T54
MBD1057-T80	100	200	0.65	1,000	180	2.5	420	135	T80
MBD2057-E28 / 28X	200	300	0.40	750	130	2.5	410	130	E28 / 28X
MBD2057-H20	200	300	0.50	750	130	2.5	410	130	H20
MBD2057-T54	200	300	0.55	750	130	2.5	410	130	T54
MBD2057-T80	200	300	0.65	750	130	2.5	410	130	T80
MBD3057-E28 / 28X	300	400	0.45	500	80	2.5	400	125	E28 / 28X
MBD3057-H20	300	400	0.55	500	80	2.5	400	125	H20
MBD3057-T54	300	400	0.60	500	80	2.5	400	125	T54
MBD3057-T80	300	400	0.70	500	80	2.5	400	125	T80
MBD4057-E28 / 28X	400	500	0.50	275	65	2.5	400	120	E28 / 28X
MBD4057-H20	400	500	0.60	275	65	2.5	400	120	H20
MBD4057-T54	400	500	0.65	275	65	2.5	400	120	T54
MBD4057-T80	400	500	0.75	275	65	2.5	400	120	T80
MBD5057-E28 / 28X	500	600	0.55	250	60	2.5	400	110	E28 / 28X
MBD5057- H20	500	600	0.65	250	60	2.5	400	110	H20
MBD5057- T54	500	600	0.70	250	60	2.5	400	110	T54
MBD5057- T80	500	600	0.80	250	60	2.5	400	110	T80
Test Conditions			$V_R = V_V$ $F = 100 \text{ MHz}$	$P_{IN} = -20 \text{ dBm}$ $R_L = 10 \text{ K}\Omega \text{ } F = 10 \text{ GHz}$			$I_R = 500 \mu\text{A}$	$I_F = 3 \text{ mA}$	

# Planar Back (Tunnel) Diodes MBD Series



Typical Performance,  $T_A = 25\text{ }^\circ\text{C}$

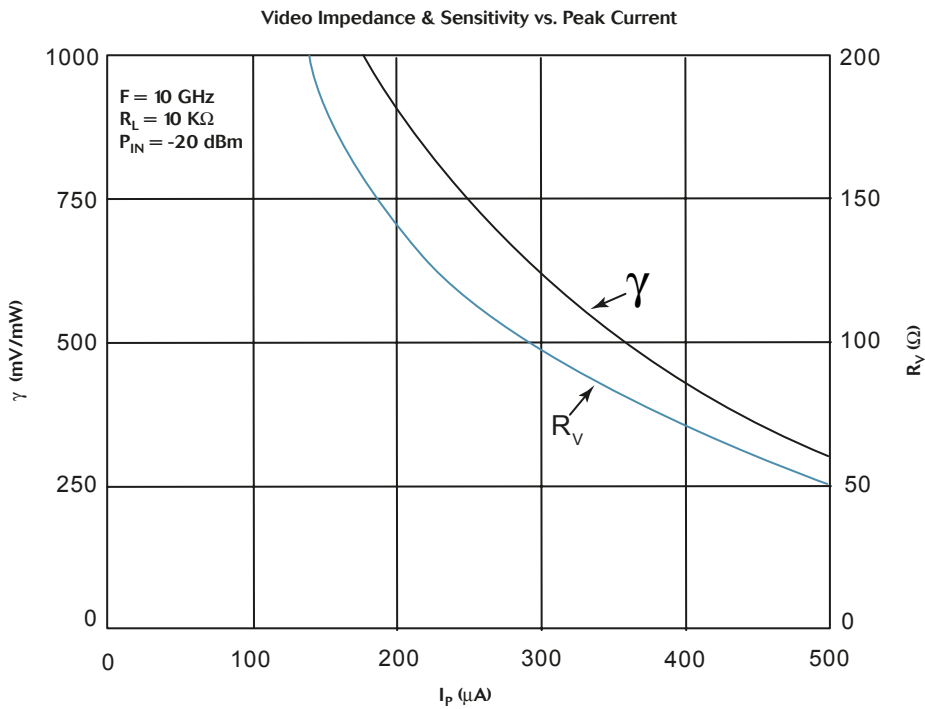
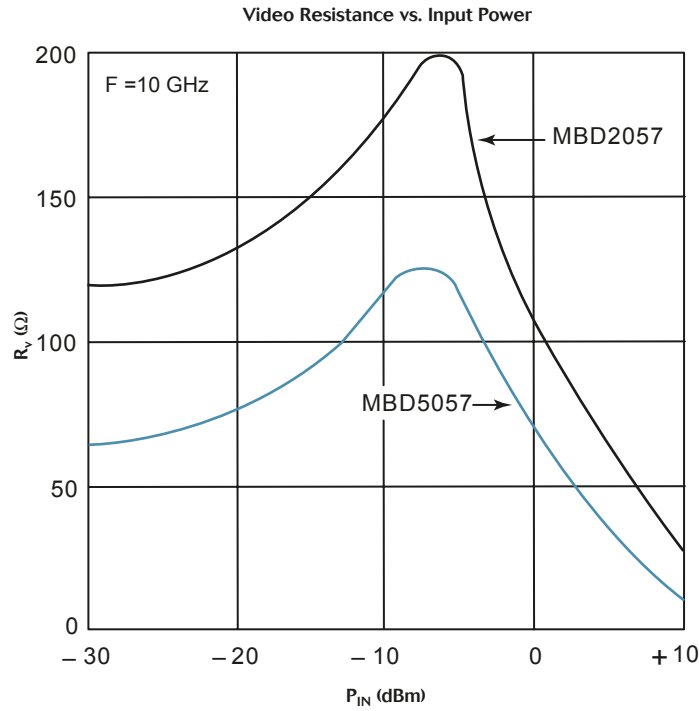

Typical Performance,  $T_A = 25\text{ }^\circ\text{C}$ ,

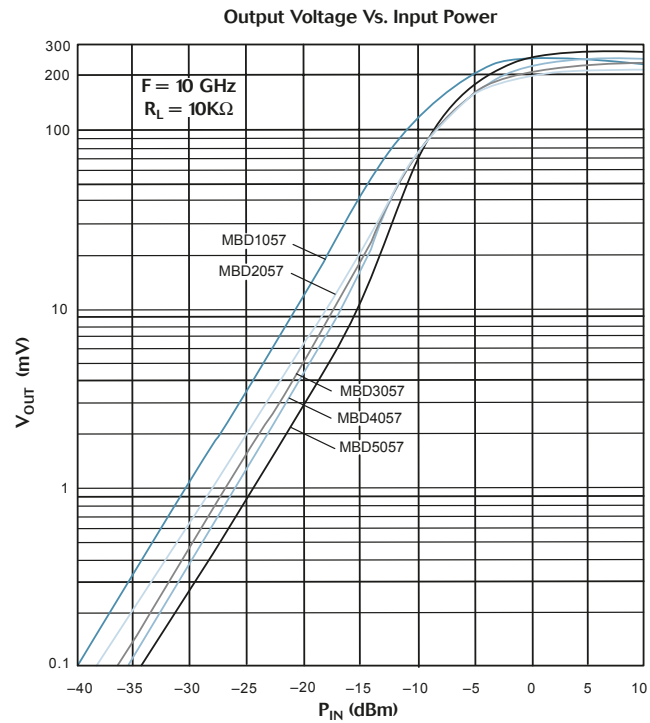

**10 GHz RF Detector Test Circuit**

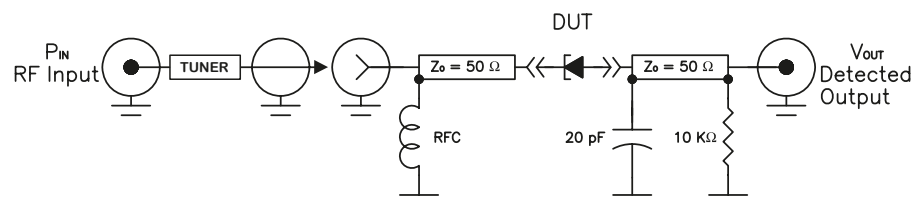

# Planar Back (Tunnel) Diodes MBD Series

Typical Performance,  $T_A = 25^\circ\text{C}$ , MDB2057

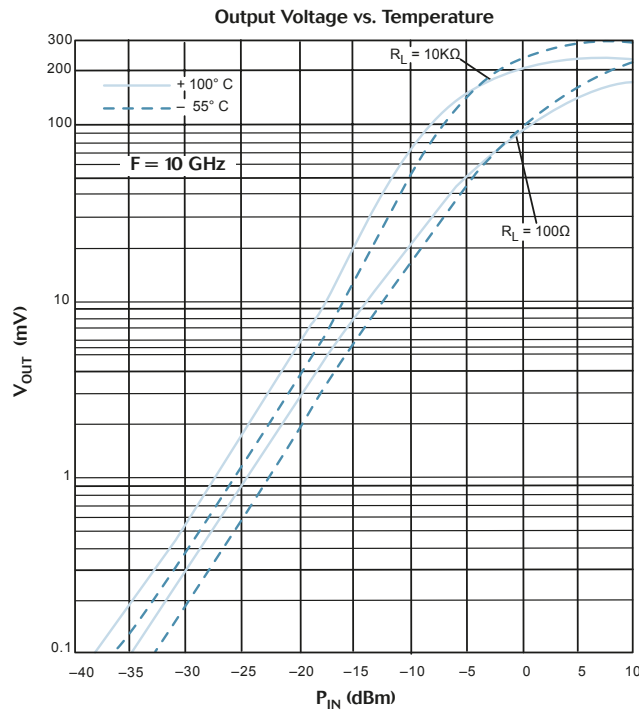
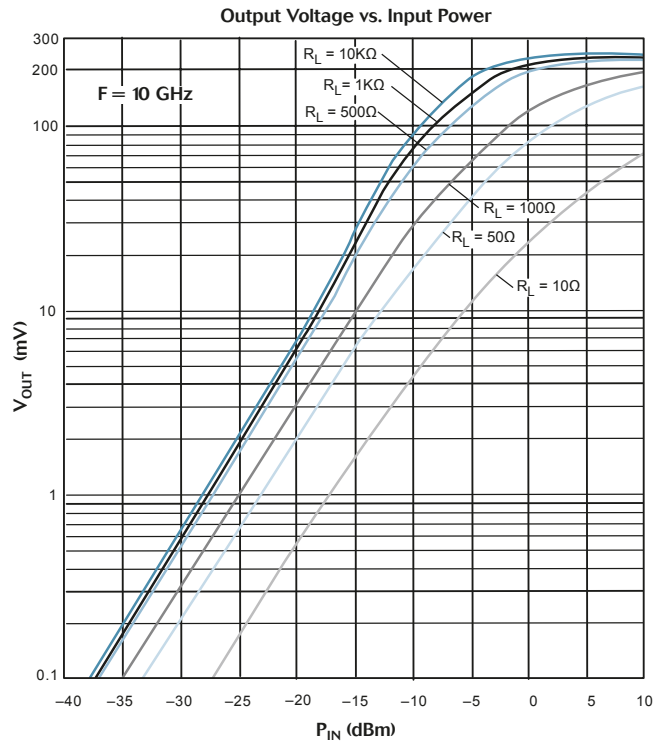

Typical Performance,  $T_A = 25\text{ }^\circ\text{C}$ , MDB5057

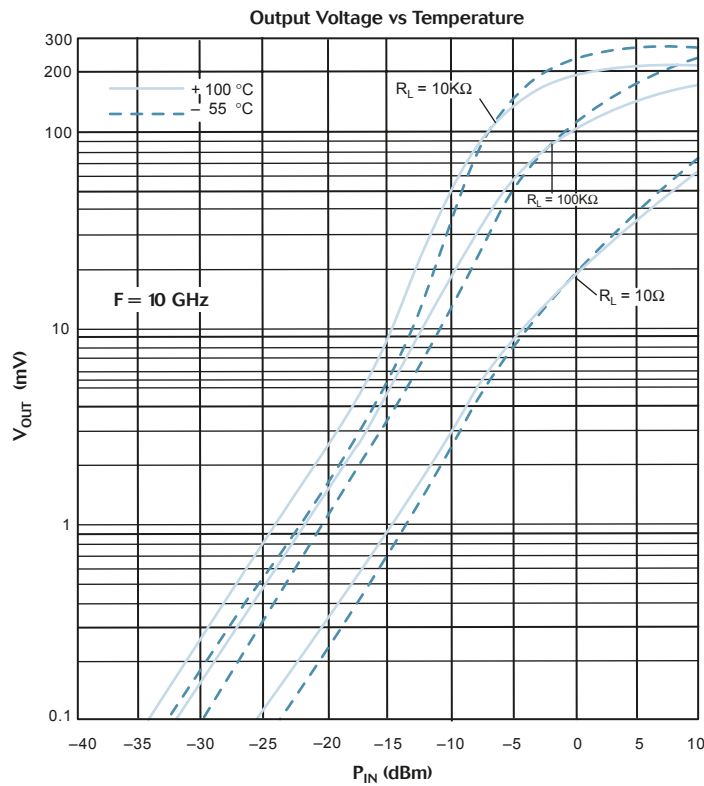
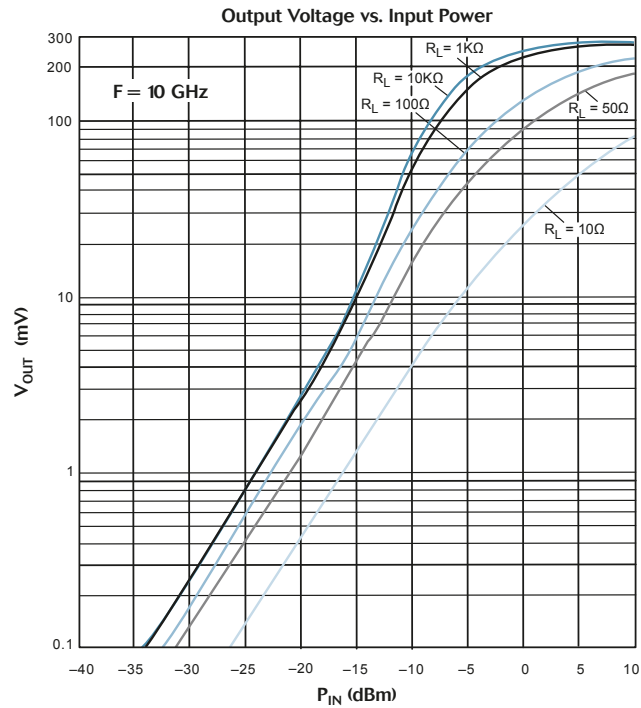

# Planar Back (Tunnel) Diodes MBD Series

## Outline Drawings

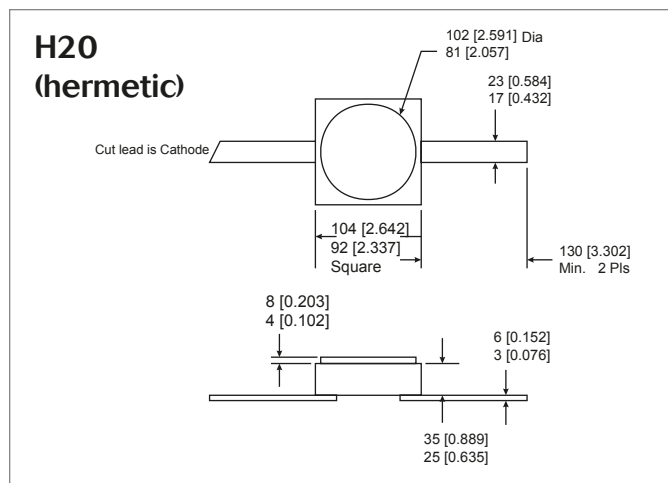
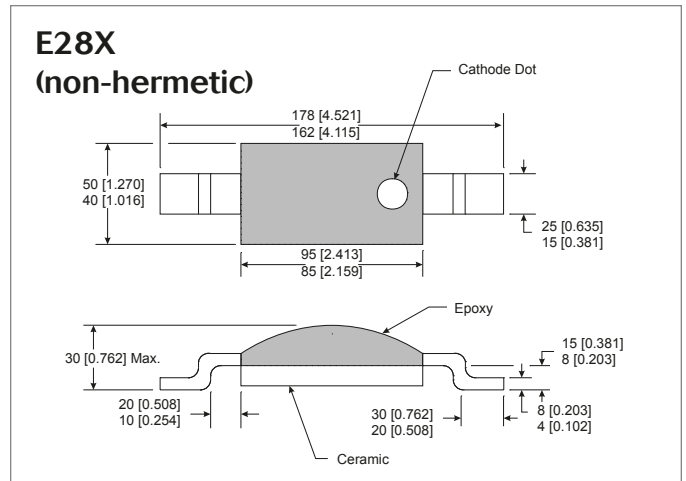
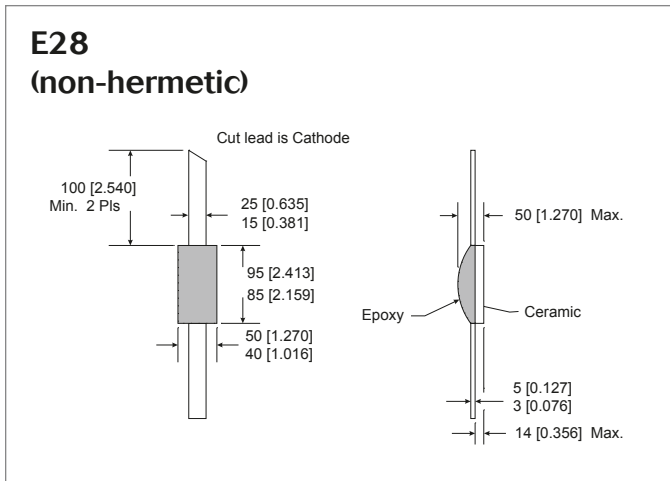
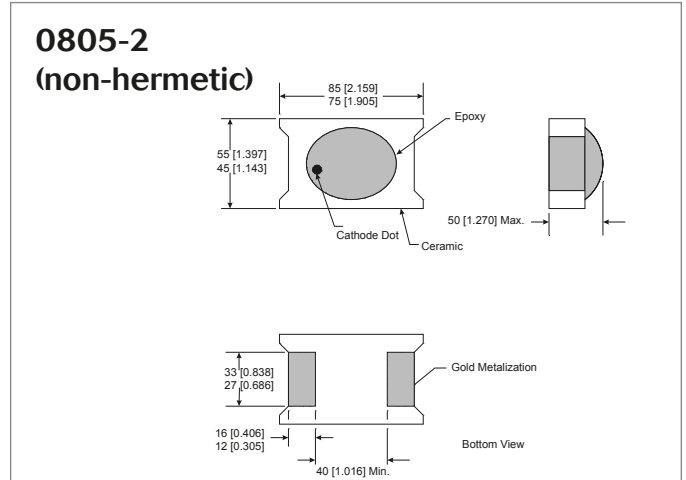
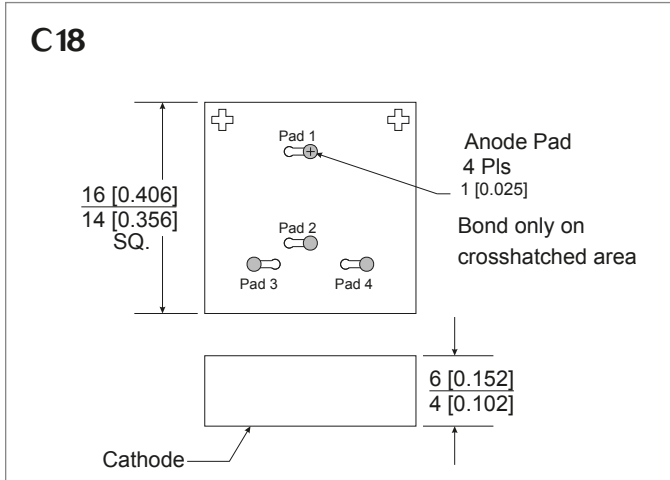

# Planar Back (Tunnel) Diodes MBD Series

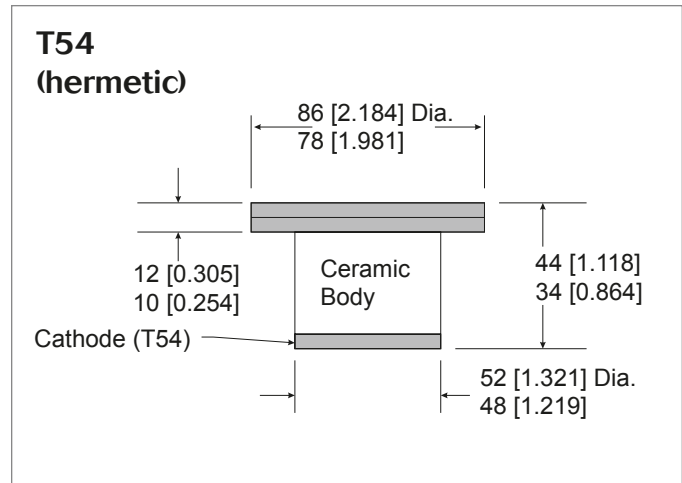
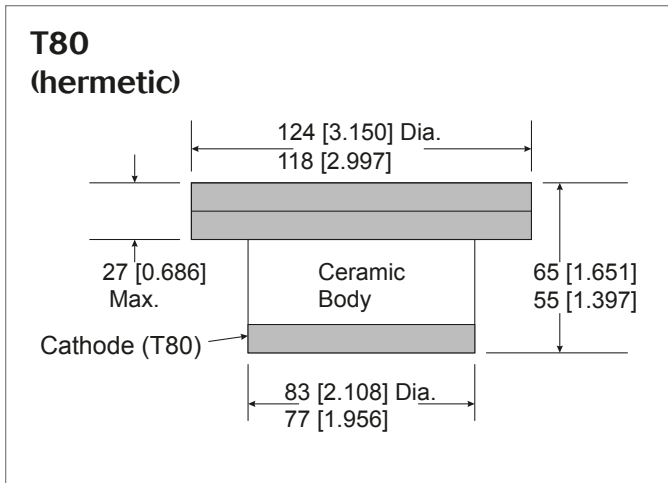

## CHIP ASSEMBLY

The germanium planar back (tunnel) diode is sensitive to mechanical pressure and high temperatures.

**Die attach:** Conductive epoxy only with maximum curing temperature of +125°C

**Wire Bond:** 0.7 mil Gold wire and thermo-compression wedge bond within the following:

- Stage Temperature: +155 °C maximum for 20 seconds max
- Tip Temperature: +160 °C maximum
- Bonding Pressure: 20 grams maximum

Bonding is performed on the larger diameter offset bonding pad (see figure 1) and not over the junction.



figure 1

**Aeroflex / Metelics**

Aeroflex Microelectronic Solutions  
975 Stewart Drive, Sunnyvale, CA 94085  
TEL: 408-737-8181  
Fax: 408-733-7645

[www.aeroflex-metelics.com](http://www.aeroflex-metelics.com)

[sales@eroflex-metelics.com](mailto:sales@eroflex-metelics.com)



Aeroflex / Metelics, Inc. reserves the right to make changes to any products and services herein at any time without notice. Consult Aeroflex or an authorized sales representative to verify that the information in this data sheet is current before using this product. Aeroflex does not assume any responsibility or liability arising out of the application or use of any product or service described herein, except as expressly agreed to in writing by Aeroflex; nor does the purchase, lease, or use of a product or service from Aeroflex convey a license under any patent rights, copyrights, trademark rights, or any other of the intellectual rights of Aeroflex or of third parties. Copyright 2003 Aeroflex / Metelics. All rights reserved.



Our passion for performance is defined by three attributes represented by these three icons: solution-minded, performance-driven and customer-focused.