

MSS20,000 Series Zero Bias Schottky Diodes



Description

The Aeroflex / Metelics MSS20,000 series of Schottky diodes is fabricated on P-Type epitaxial substrates for superior 1/f noise performance in microwave zero-bias detector applications up to 40 GHz.

Features

- Very low 1/f Noise
- Detector applications to 40 GHz
- Chip, beam lead or packaged devices

Absolute Maximum Ratings

Parameters	Rating
Reverse Voltage	1.0 Volts
Forward Current	35 mA
Operation Temperature	-65 °C to +150 °C
Storage Temperature	-65 °C to +150 °C
CW Power Dissipation	100 mW, derated linearly to zero at $T_A = +150$ °C
Soldering Temperature (Packaged)	+ 230 °C for 5 sec.

Chip

Electrical Specifications, $T_A = 25$ °C

Model	C_j MAX pF	T_{ss} TYP dBm	R_v MIN Ω	R_v MAX Ω	γ TYP mV / mW	Frequency MAX GHz	Outline
MSS20,046-C15	0.10	-58	1000	2000	5000	18	C15
MSS20,047-C15	0.10	-59	2000	6000	8000	18	C15
MSS20,050-C15	0.15	-58	1000	2000	5000	12	C15
MSS20,051-C15	0.15	-59	2000	6000	8000	12	C15
MSS20,054-C15	0.20	-58	1000	2000	5000	8	C15
MSS20,055-C15	0.20	-59	2000	6000	8000	8	C15
Test Conditions	f = 1 MHz $V_R = 0$ V	f = 10 GHz NF = 3dB	$P_{IN} = -30$ dBm Video BW = 500 KHz		$R_L = 1$ M Ω		



Beam Lead

Electrical Specifications, $T_A = 25\text{ }^\circ\text{C}$

Model	C_j MAX pF	T_{ss} TYP dBm	R_V MIN Ω	R_V MAX Ω	γ TYP mV / mW	Frequency MAX GHz	Outline
MSS20,140-B10D	0.08	-58	1000	2000	5000	40	B10D
MSS20,141-B10D	0.08	-59	2000	6000	8000	40	B10D
MSS20,142-B10D	0.10	-58	1000	2000	5000	26	B10D
MSS20,143-B10D	0.10	-59	2000	6000	8000	26	B10D
MSS20,145-B10D	0.12	-58	1000	2000	5000	18	B10D
MSS20,146-B10D	0.12	-59	2000	6000	8000	18	B10D
Test Conditions	f = 1 MHz $V_R = 0\text{ V}$	f = 10 GHz NF = 3dB	$P_{IN} = -30\text{ dBm}$ Video BW = 500 KHz		$R_L = 1\text{ M}\Omega$		

Packaged

Electrical Specifications, $T_A = 25\text{ }^\circ\text{C}$

Model	C_T MAX pF	T_{ss} TYP dBm	R_V MIN Ω	R_V MAX Ω	γ TYP mV / mW	Frequency MAX GHz	Outline
MSS20,046-H27	0.22	-58	1000	2000	5000	18	H27
MSS20,046-E25	0.18	-58	1000	2000	5000	18	E25
MSS20,046-T86	0.28	-58	1000	2000	5000	18	T86
MSS20,047-H27	0.22	-59	2000	6000	8000	18	H27
MSS20,047-E25	0.18	-59	2000	6000	8000	18	E25
MSS20,047-T86	0.28	-59	2000	6000	8000	18	T86
MSS20,050-H27	0.27	-58	1000	2000	5000	12	H27
MSS20,050-E25	0.23	-58	1000	2000	5000	12	E25
MSS20,050-T86	0.33	-58	1000	2000	5000	12	T86
MSS20,051-H27	0.27	-59	2000	6000	8000	12	H27
MSS20,051-E25	0.23	-59	2000	6000	8000	12	E25
MSS20,051-T86	0.33	-59	2000	6000	8000	12	T86
MSS20,054-H27	0.32	-58	1000	2000	5000	8	H27
MSS20,054-E25	0.28	-58	1000	2000	5000	8	E25
MSS20,054-T86	0.38	-58	1000	2000	5000	8	T86
MSS20,055-H27	0.32	-59	2000	6000	8000	8	H27
MSS20,055-E25	0.28	-59	2000	6000	8000	8	E25
MSS20,055-T86	0.38	-59	2000	6000	8000	8	T86
Test Conditions	f = 1 MHz $V_R = 0\text{ V}$	f = 10 GHz NF = 3dB	$P_{IN} = -30\text{ dBm}$ Video BW = 500 KHz		$R_L = 1\text{ M}\Omega$		

MSS20,000 Series Zero Bias Silicon Schottky Diodes



Typical Performance, $T_A = 25\text{ }^\circ\text{C}$

Figure 1.

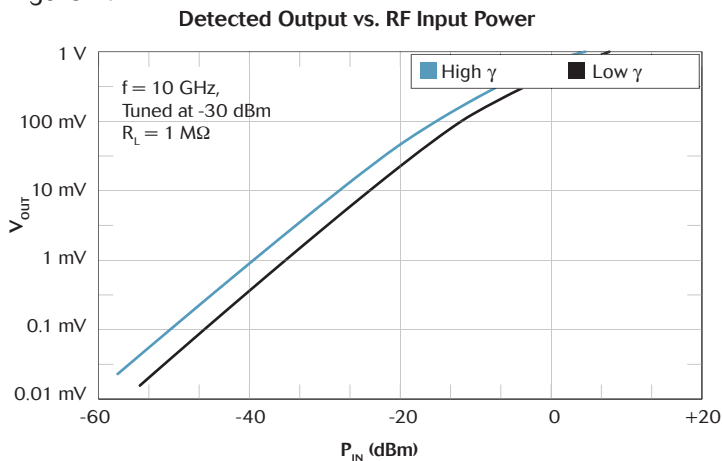

Figure 2.

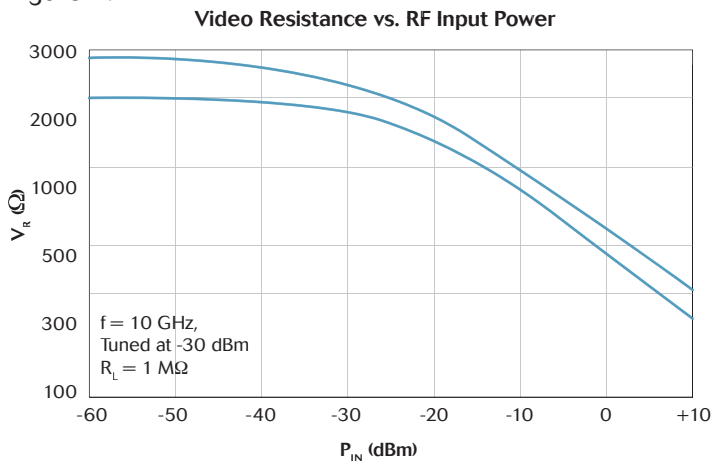
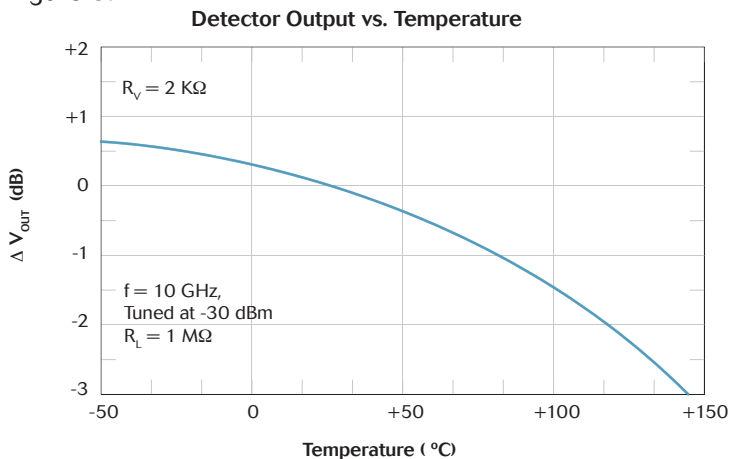
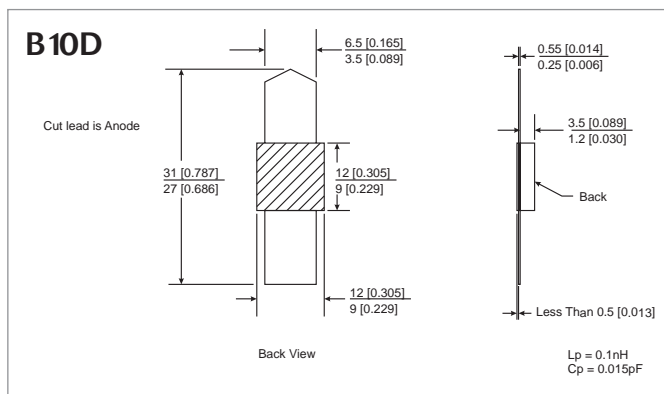
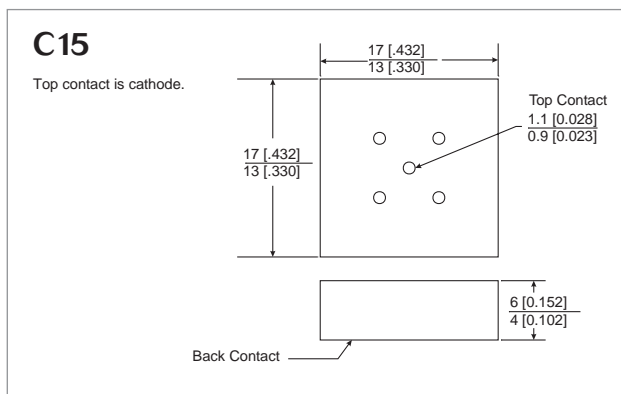

Figure 3.



Outline Drawings



Outline Drawings

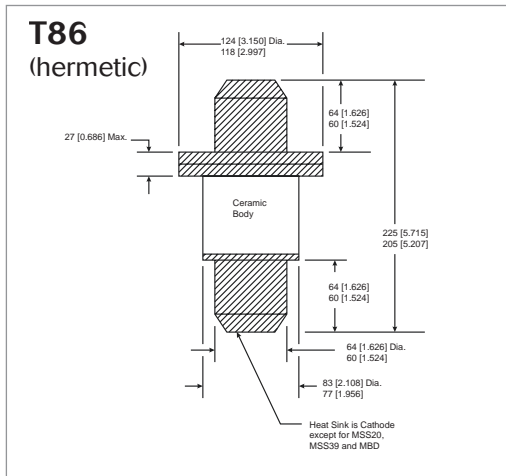
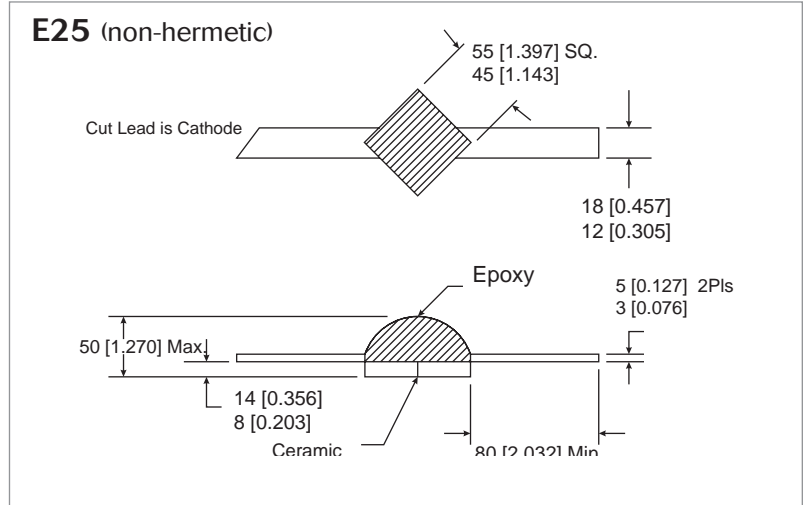
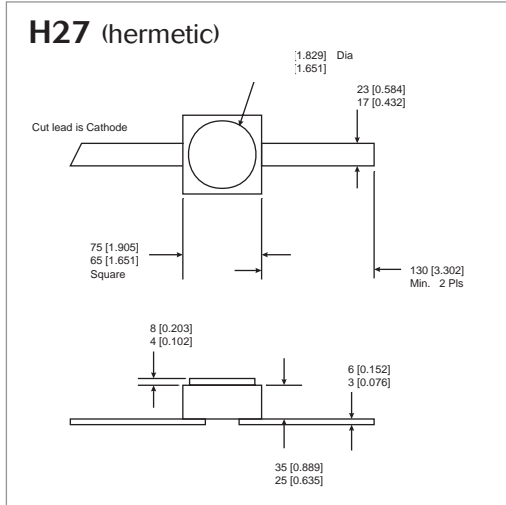

Aeroflex / Metelics
 Aeroflex Microelectronic Solutions
 975 Stewart Drive, Sunnyvale, CA 94085
 TEL: 408-737-8181
 Fax: 408-733-7645

www.aeroflex-metelics.com sales@eroflex-metelics.com

Aeroflex / Metelics, Inc. reserves the right to make changes to any products and services herein at any time without notice. Consult Aeroflex or an authorized sales representative to verify that the information in this data sheet is current before using this product. Aeroflex does not assume any responsibility or liability arising out of the application or use of any product or service described herein, except as expressly agreed to in writing by Aeroflex; nor does the purchase, lease, or use of a product or service from Aeroflex convey a license under any patent rights, copyrights, trademark rights, or any other of the intellectual rights of Aeroflex or of third parties. Copyright 2003 Aeroflex / Metelics. All rights reserved.



Our passion for performance is defined by three attributes represented by these three icons: solution-minded, performance-driven and customer-focused.