

Spice does not contain a model for the Tunnel Diode. To correct this omission, use the macromodel shown below.

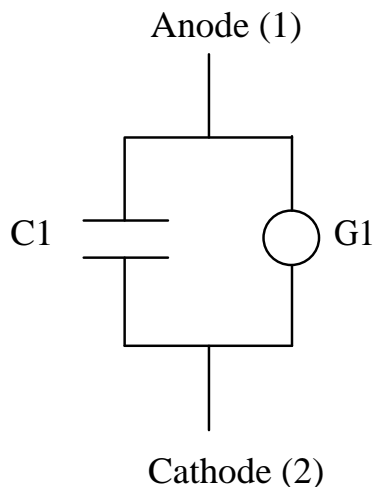

G1 models the reverse and forward bias IV curve. The model does not accurately represent the negative differential resistance region of the IV curve (from the peak to the valley of the IV curve). Also the model does not contain temperature effects. Range for C1 is 0.21 to 0.63pF

Macromodel for MBD1057

```
.SUBCKT MBD1057 1 2    1 - Anode  2 - Cathode
C1 1 2 0.3E-12
G1 1 2 1 2 -1.7203328E-5 0.00619832 -0.077360801 0.3165614
+ -0.11350153 -2.399187 5.852578 -4.0954452
.ENDS
```

Values for G1								
G1 1 2 1 2 A B C D E F G H								
Part Number	A	B	C	D	E	F	G	H
MBD1057	-1.7203328E-5	0.00619832	-0.077360801	0.3165614	-0.11350153	-2.399187	5.852578	-4.0954452
MBD2057	-4.2853473E-5	0.01179656	-0.137835922	0.4751648	0.66459596	-7.829686	17.074219	-11.984191
MBD3057	-8.563517E-5	0.0135898	-0.1382201	0.51494522	-0.7468726	0.4266882	-0.894022	1.5872685
MBD4057	-4.665016E-5	0.0162544	-0.1933425	0.6997977	0.7455009	-10.991460	25.534064	-18.939896
MBD5057	-4.7320493E-5	0.0186667	-0.1982379	0.6078641	1.2530528	-11.887154	25.874105	-18.642391

Example circuit to generate IV curve of tunnel diode.

Tunnel Diode

```
.DC V1 -60.0E-3 470.0E-3 10.0E-3
```

```
.PRINT DC I(V2)
```

```
V1 1 0 0
```

```
X1 1 2 MBD1057
```

```
V2 2 0 0
```

```
.SUBCKT MBD1057 1 2
```

```
C1 1 2 0.3E-12
```

```
G1 1 2 1 2 -1.7203328E-5 0.00619832 -0.077360801 0.3165614
```

```
+ -0.11350153 -2.399187 5.852578 -4.0954452
```

```
.ENDS
```

```
.END
```

Metelics provides Spice models that may be used and distributed freely, provided they are not changed in any way, resold or included in any other package for resale. These models are furnished on an "as is" basis without warranty of any kind. Metelics reserves the right to make changes to any model without notice. Although the use of models can be a useful tool in evaluating devices for applications, they do not exactly model all device characteristics under all conditions.