

# Surface Mount PIN Diode Limiter

## LM202802-Q-C-301 Series Datasheet



### Features

- Surface Mount Limiter in Compact Outline:  
8mm L x 5mm W x 2.5 mm H
- Incorporates PIN Limiter & Schottky Diodes, D.C. Blocks & D.C. Return
- Higher Average Power Handling than Plastic ( 100 W C.W. Power )
- Lower Insertion Loss ( 1.1 dB ) & Lower Flat Leakage Power ( 21 dBm )
- RoHS Compliant



### Description

The LM202802-Q-C-301 Surface Mount Silicon PIN Diode Limiter is manufactured using Aeroflex / Metelics proven hybrid manufacturing process incorporating PIN Diodes and passive devices integrated within a ceramic substrate. This low profile, compact , surface mount component, ( 8mm L x 5mm W x 2.5 mm H ) offers superior low and high signal performance to comparable MMIC devices in QFN packages. The Limiter Modules are designed to optimize small signal insertion loss, (N.F.) and high signal flat leakage performance in a compact, surface mount package.

Using PIN Diodes with lower thermal resistance ( < 20 °C/W ), and a de-coupled Schottky detector network as a current source, RF C.W. incident power levels of +50 dBm and RF peak incident power levels of +60 dBm @ 25 μS RF pulse width, 5% duty cycle are very achievable. In addition, this design concept provides lower flat leakage power ( < +21 dBm ) and lower spike leakage energy ( < 0.5 Ergs ) for superior LNA protection. The LM202802-Q-C-301 limiter can be configured without a D.C. block on the output to obtain lower flat leakage power, ( < +10 dBm ) with an external ZBD schottky diode. This Limiter Part Number is LM202802-Q-B-301. Schottky diode P/N in surface mount, 3 terminal plastic package is MZB601-2012.

### Applications

These LM202802-Q-C-301 and LM202802-Q-B-301 Limiters are ideal for octave band Radar applications, from 2-8 GHz, requiring high volume, surface mount, solder re-flow manufacturing. These products are durable, reliable, and capable of meeting all military, commercial, and industrial environments. The devices are fully RoHS compliant and are available in tube or tape-reel.

### Environmental Capabilities

The LM202802-Q-C-301 and LM202802-Q-B-301 Limiters are capable of meeting the environmental requirements of MIL-STD-750 and MIL-STD-202.

### ESD and Moisture Sensitivity Level Rating

PIN Diode Limiters are susceptible to ESD conditions as with all semiconductors. The ESD rating for this device is Class 0, HBM. The moisture sensitivity level rating for this device is MSL 2.



## LM202802-Q-C-301 & LM202802-Q-B-301 Electrical Specifications @ $Z_0 = 50 \Omega$ , $T_A = +25 \text{ }^\circ\text{C}$ (Unless Otherwise Defined)

Parameter	Symbol	Units	Test Conditions	Minimum Value	Typical Value	Maximum Value
Frequency	F	GHz	Swept Frequency	1.5	2.0 - 8.0	8.5
Insertion Loss	$I_L$	dB	Swept Frequency $P_o = 0 \text{ dBm}$		-1.1	-1.4
Return Loss	$R_L$	dB	Swept Frequency $P_o = 0 \text{ dBm}$	-13	-15	
Input Compression Power	P1dB	dBm	Swept Frequency	+8	+10	+12
2nd Harmonic	$2F_o$	dBc	$P_o = 0 \text{ dBm}$ $F_o = 500 \text{ MHz}$	45	50	
Peak Incident Power	$P_{inc}(Pk)$	dBm	RF Pulse Width = 25 $\mu\text{s}$ , 5% duty		+60	+60
C.W. Incident Power	$P_{inc}(CW)$	dBm	Swept Frequency		+50	+51
Flat Leakage Power	$P_f$	dBm	+60 dBm, RF Pulse Width = 25 $\mu\text{s}$ , 5% duty		+21	+23
Spike Leakage Energy	$E_s$	Ergs	+60 dBm, RF Pulse Width = 25 $\mu\text{s}$ , 5% duty		0.5	0.6
Recovery Time	$T_r$	$\eta\text{S}$	+60 dBm, RF Pulse Width = 25 $\mu\text{s}$ , 5% duty ( 50% Trailing RF Pulse - 1dB IL )		5	10

## LM202802-Q-C-301 and LM202802-Q-B-301 Absolute Maximum Ratings

Parameter	Absolute Maximum Value
Operating Temperature	-65 $^\circ\text{C}$ to +125 $^\circ\text{C}$
Storage Temperature	-65 $^\circ\text{C}$ to +150 $^\circ\text{C}$
Junction Temperature	+175 $^\circ\text{C}$
RF C.W. Incident Power @ +85 $^\circ\text{C}$ Source & Load VSWR < 1.2:1	+50 dBm
RF Peak. Incident Power @ +85 $^\circ\text{C}$ Source & Load VSWR < 1.2:1	+60 dBm, RF Pulse Width = 25 $\mu\text{s}$ , 5% duty cycle +60 dBm, RF Pulse Width = 50 $\mu\text{s}$ , 1% duty cycle
Insertion Loss Rate of Change with Operating Temperature	- 0.005 dB / $^\circ\text{C}$
$\theta_{jc}$ C.W. Thermal Resistance ( Junction to Case )	10 $^\circ\text{C/W}$
Assembly Temperature	+260 $^\circ\text{C}$ for 10 Seconds

# PIN Diode Limiter

### LM202802-Q-C-301 Limiter Schematic

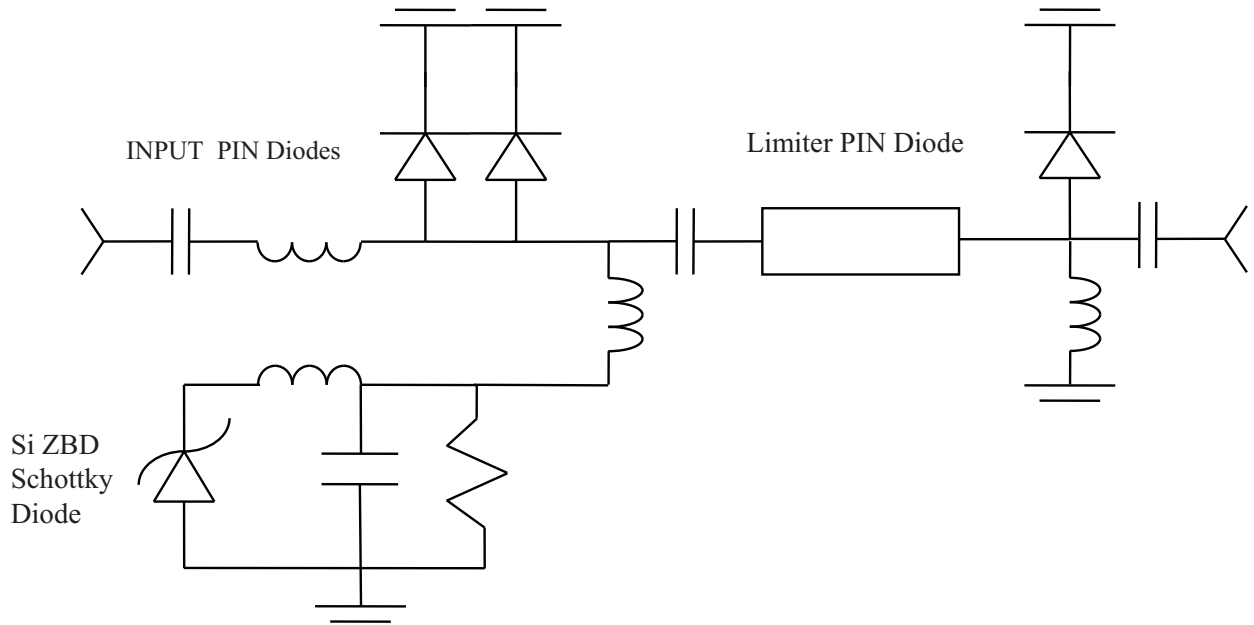

### LM202802-Q-B-301 Limiter Schematic

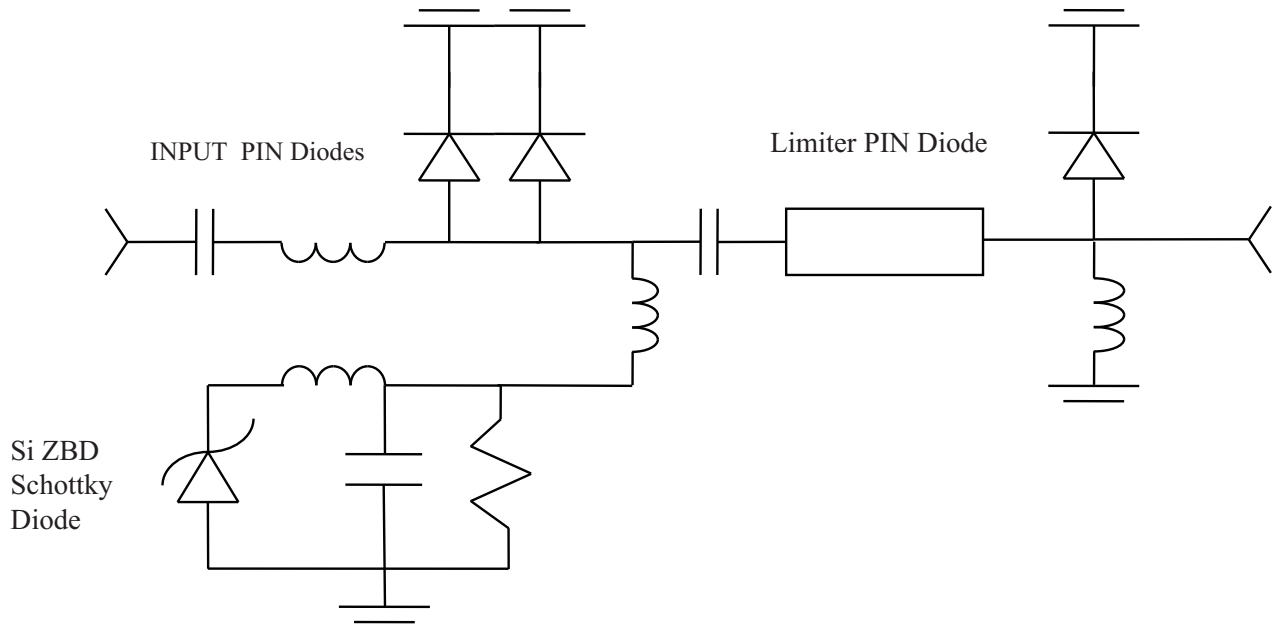

## Assembly Instructions

The LM202802-Q-B-301 and LM202802-Q-C-301 Limiters are capable of being placed onto circuit boards with pick and place manufacturing equipment from tube or tape-reel dispensing. The devices are attached to the circuit board using conventional solder re-flow or wave soldering procedures with RoHS type or Sn 63 / Pb 37 type solders per Table I and Graph I Time-Temperature recommended profile.

Table 1: Time-Temperature Profile for Sn 60/Pb40 or RoHS Type Solders

Profile Feature	Sn-Pb Eutectic Assembly	Pb-Free Assembly
Average ramp-up rate (T <sub>L</sub> to T <sub>P</sub> )	3°C/second maximum	3°C/second maximum
Preheat - Temperature Minimum (T <sub>S MIN</sub> ) - Temperature Maximum (T <sub>S MAX</sub> ) - Time (Minimum to maximum) (t <sub>s</sub> )	100°C 150°C 60-120 seconds	150°C 200°C 60-180 seconds
T <sub>S MAX</sub> to T <sub>L</sub> - Ramp-up Rate		3°C/second maximum
Time Maintained above: - Temperature (T <sub>L</sub> ) - Time (t <sub>L</sub> )	183°C 60-150 seconds	217°C 60-150 seconds
Peak Temperature (T <sub>P</sub> )	225 +0 / -5°C	245 +0/-5°C
Time within 5°C of actual Peak Temperature (T <sub>P</sub> )	10-30 seconds	20-40 seconds
Ramp-down Rate	6°C/second maximum	6°C/second maximum
Time 25°C to Peak Temperature	6 minutes maximum	8 minutes maximum

### Graph1: Solder Re-Flow Time-Temperature Function

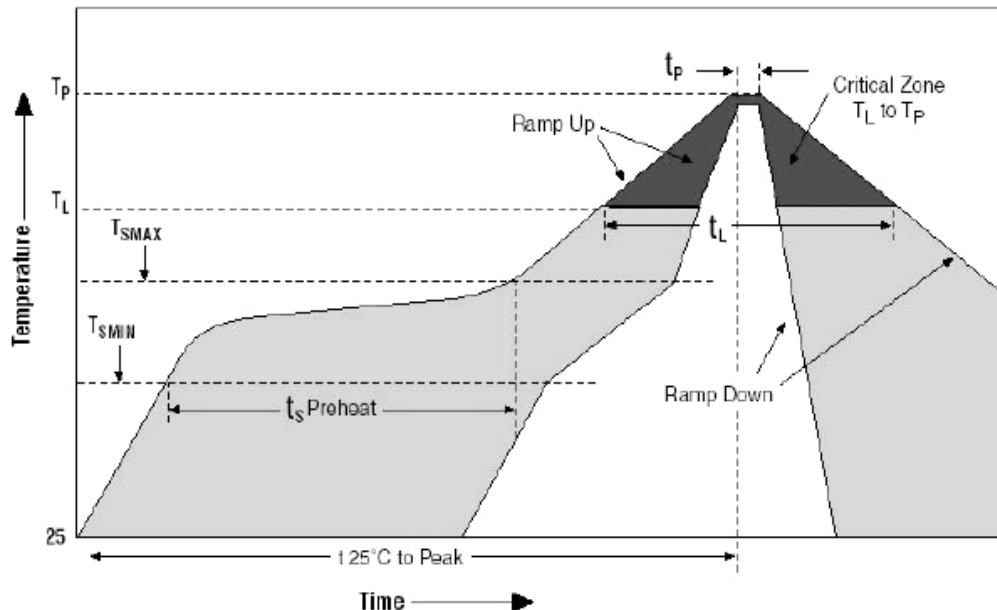

## Low Signal Parametric Performance @ 0dBm

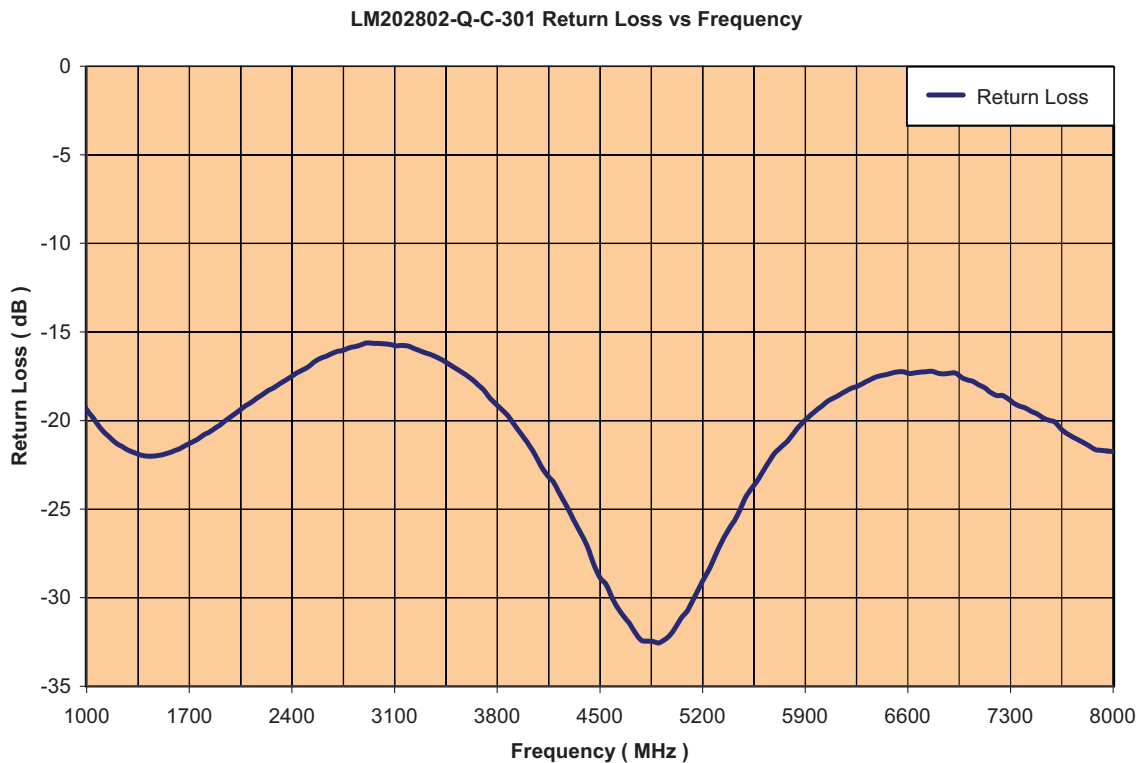
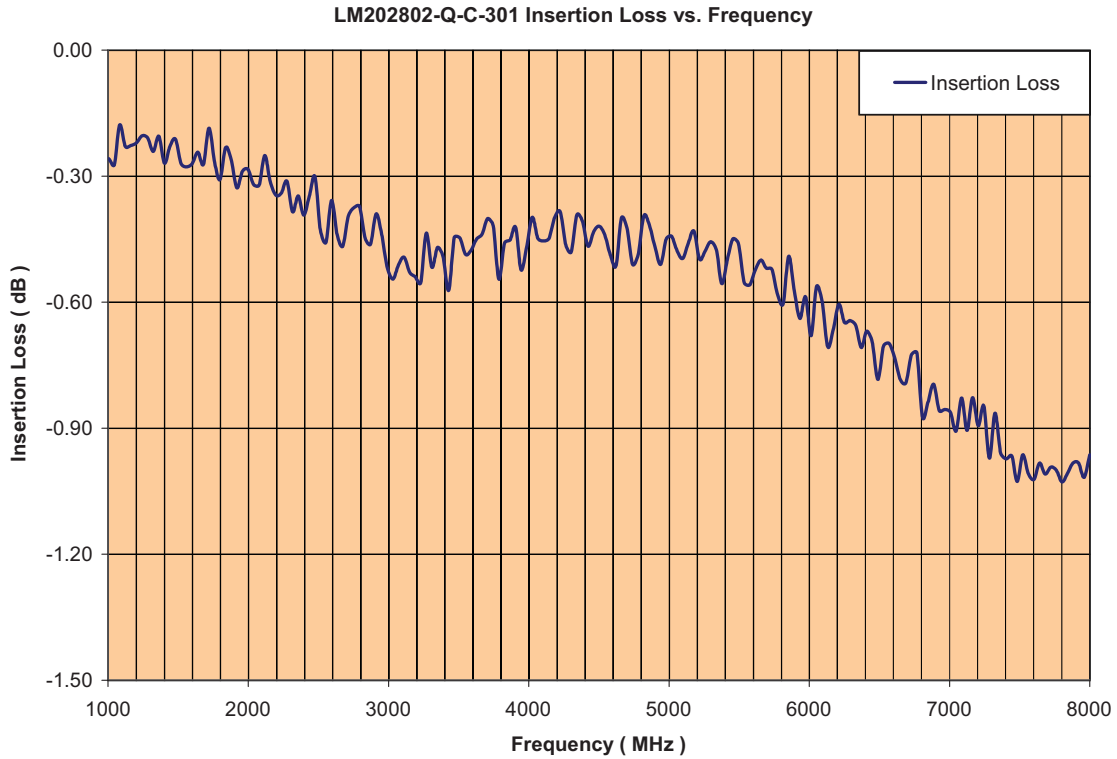

## High Signal Parametric Data

LM202802-Q-C-301 Pout vs Pin C.W. Performance

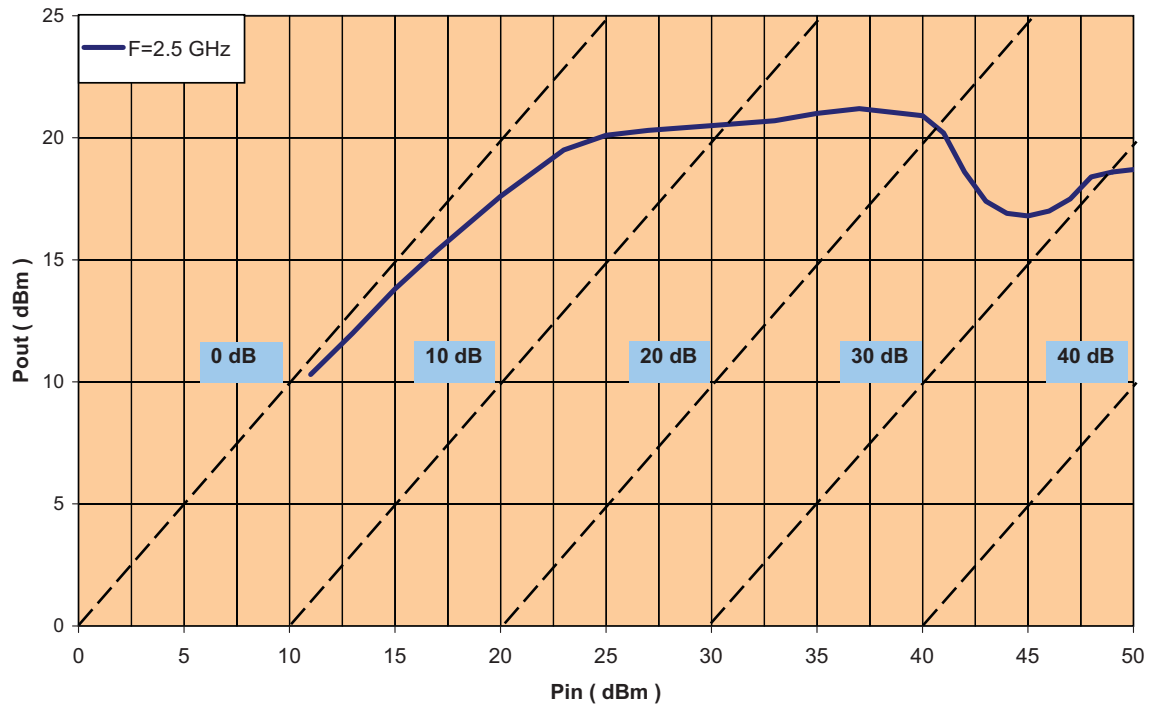

# PIN Diode Limiter

## LM202802-Q-B-301 and LM202802-Q-C-301 Outline Drawing, Case Style 301, (CS301)

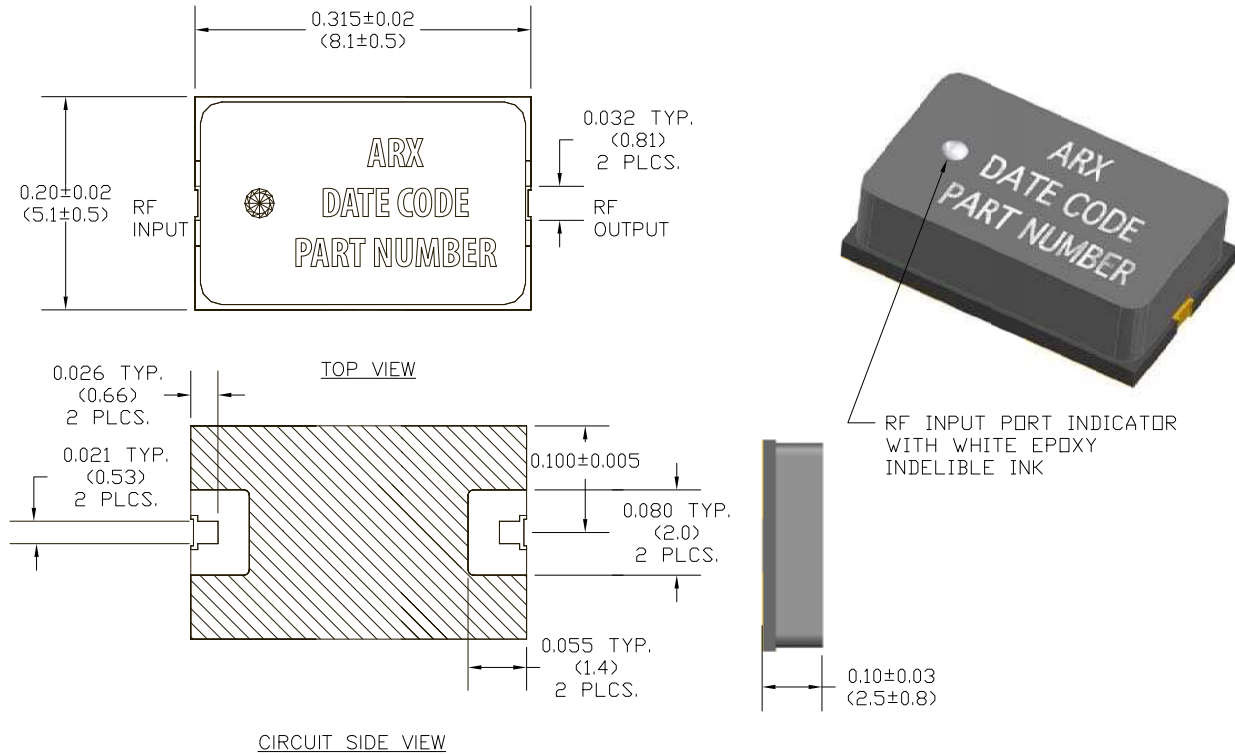

- NOTES:
1. SUBSTRATE MATERIAL: 20 MIL THICK ALUMINA NITRIDE (ALN) RF COVER: BLACK CERAMIC.
  2. TOP SIDE AND BACKSIDE METALLIZATION: 100 μ IN. TYPICAL PLATED Au OVER Ti-Pd.
  3. DIMENSION IN PARENTHESIS ARE IN MM.

## RF Circuit Solder Footprint for Case Style 301 (CS 301)

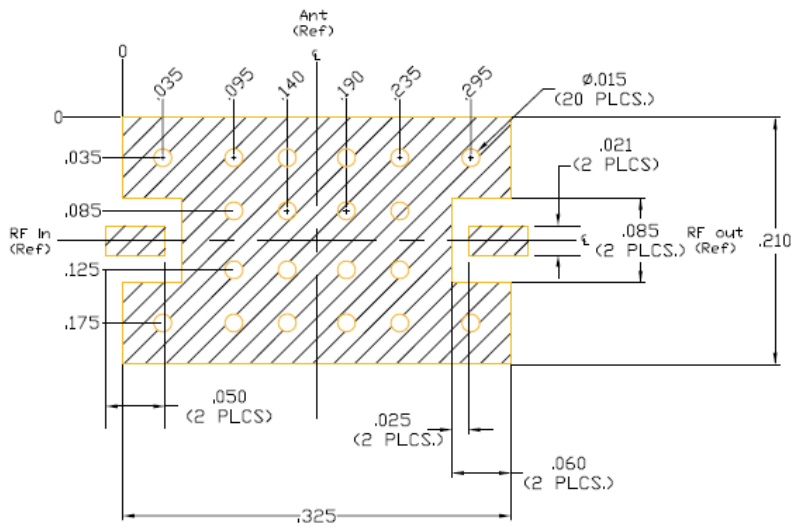

- NOTES:
1. RECOMMENDED RF CIRCUIT IS ROGERS, R04350B, 10 MILS THICK.

Thatched Area is RF, D.C., and Thermal Ground. Vias should be solid copper fill and gold plated for optimum heat transfer from backside of limiter module through Circuit Vias to metal thermal ground.

## Part Number Ordering Information:

Part Number	DC Blocking Configuration	Description
LM202802-Q-C-301-T	D.C. Blocks on Input & Output	Tube Packaging
LM202802-Q-C-301-R	D.C. Blocks on Input & Output	Tape-Reel Packaging Quantities of 250 or 500
LM202802-Q-C-301-W	D.C. Blocks on Input & Output	Waffle Packaging
LM202802-Q-C-301-E	D.C. Blocks on Input & Output	RF Evaluation Board
LM202802-Q-B-301-T	D.C. Block on Input Only	Tube Packaging
LM202802-Q-B-301-R	D.C. Block on Input Only	Tape-Reel Packaging Quantities of 250 or 500
LM202802-Q-B-301-W	D.C. Block on Input Only	Waffle Packaging
LM202802-Q-B-301-E	D.C. Block on Input Only	RF Evaluation Board

### Aeroflex / Metelics, Inc.

54 Grenier Field Road, Londonderry, NH 03053  
 Tel: (603) 641-3800  
 Sales: (888) 641-SEMI (7364)  
 Fax: (603)-641-3500

975 Stewart Drive, Sunnyvale, CA 94085  
 Tel: (408) 737-8181  
 Fax: (408) 733-7645

[www.aeroflex.com/metelics](http://www.aeroflex.com/metelics)      [metelics-sales@aeroflex.com](mailto:metelics-sales@aeroflex.com)

Aeroflex / Metelics, Inc. reserves the right to make changes to any products and services herein at any time without notice. Consult Aeroflex or an authorized sales representative to verify that the information in this data sheet is current before using this product. Aeroflex does not assume any responsibility or liability arising out of the application or use of any product or service described herein, except as expressly agreed to in writing by Aeroflex; nor does the purchase, lease, or use of a product or service from Aeroflex convey a license under any patent rights, copyrights, trademark rights, or any other of the intellectual rights of Aeroflex or of third parties.

Copyright 2011 Aeroflex / Metelics. All rights reserved.

ISO 9001:2008 certified companies



Our passion for performance is defined by three attributes represented by these three icons: solution-minded, performance-driven and customer-focused.