

# MSW2040-204, MSW2041-204 SP2T Switch Series, 50 MHz – 4 GHz Datasheet



## Features

- Wide Frequency Range: 50 MHz to 4 GHz, in 2 bands
- Surface Mount SP2T Switch in Compact Outline: 8 mm L x 5 mm W x 2.5 mm H
- Higher Average Power Handling than Plastic Packaged MMIC Switches: 158 W CW
- High RF Peak Power: 500 W
- Low Insertion Loss: 0.25 dB
- High IIP3: 65 dBm
- Operates From Positive Voltage Only: 5 V & 28 V to 200V
- RoHS Compliant



## Applications

- High Power Transmit/Receive (TR) Switching
- Active Receiver Protection

## Description

The MSW2040-204 and MSW2041-204 series of surface mount silicon PIN diode SP2T switches can be used for high power transmit/receive (TR) switching or active receiver protection from 50 MHz to 1 GHz (MSW2040-204) or from 400 MHz to 4 GHz (MSW2041-204). These switches are manufactured using Aeroflex/Metelics proven hybrid manufacturing process incorporating high voltage PIN diodes and passive devices integrated on a ceramic substrate. These low profile, compact, surface mount components (8 mm L x 5 mm W x 2.5 mm H) offer superior small and large signal performance compared to that of MMIC devices in QFN packages. The SP2T switches are designed in a symmetrical topology to enable either switched RF port to be used as the high-input-power-handling port, to minimize insertion loss and to maximize isolation performance. The very low thermal resistance ( $< 25 \text{ }^\circ\text{C/W}$ ) of the PIN diodes in these devices enables them to reliably handle RF incident power levels of 52 dBm CW and RF peak incident power levels of 57 dBm in cold switching applications at  $T_A = 85 \text{ }^\circ\text{C}$ . The thick I layers of the PIN diodes ( $> 100 \text{ }\mu\text{m}$ ), coupled with their long minority carrier lifetime ( $> 2 \text{ }\mu\text{s}$ ), produces input third order intercept point (IIP3) greater than 65 dBm.

The MSW2040-204 and MSW2041-204 are optimized for use in applications for which high volume, surface mount, solder re-flow manufacturing is employed. These products are durable and capable of reliably operating in military, commercial, and industrial environments. The devices are RoHS compliant.

## Environmental Capabilities

The MSW2040-204 and MSW2041-204 SP2T switches are capable of meeting the environmental requirements of MIL-STD-202 and MIL-STD-750.

## ESD and Moisture Sensitivity Level Rating

PIN Diode switches are susceptible to damage from ESD events, as are all semiconductors. The ESD rating for these devices is Class 1C, HBM. The moisture sensitivity level rating is MSL 1.



## Pinout

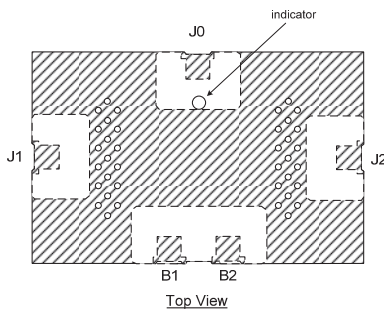

## SP2T Schematic

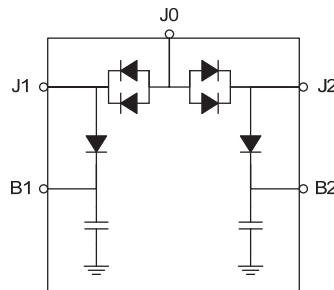

## Truth Table

Port J0 to Port J1	Port J0 to Port J2	Bias: J1 (notes 1, 2)	Bias: J2 (notes 1, 2)	B1 (notes 1, 2)	B2 (notes 1, 2)
Low loss	Isolation	$V = 0\text{ V}$ , $I = -150\text{ mA}$	$V = V_{\text{HIGH}}$ , $I = 25\text{ mA}$	$V = V_{\text{HIGH}}$ , $I = 0\text{ mA}$	$V = 0\text{ V}$ , $I = -25\text{ mA}$
Isolation	Low loss	$V = V_{\text{HIGH}}$ , $I = 25\text{ mA}$	$V = 0\text{ V}$ , $I = -150\text{ mA}$	$V = 0\text{ V}$ , $I = -25\text{ mA}$	$V = V_{\text{HIGH}}$ , $I = 0\text{ mA}$

### Notes:

- $28\text{ V} \leq V_{\text{HIGH}} \leq 200\text{ V}$ .
- PIN diode minimum reverse DC voltage ( $V_{\text{HIGH}}$ ) to maintain high resistance in the OFF PIN diode is determined by RF frequency, incident power, duty cycle, characteristic impedance and VSWR as well as by the characteristics of the diode. The recommended minimum reverse bias voltage ( $V_{\text{HIGH}}$ ) values are provided in the Minimum Reverse Bias Voltage table of this datasheet.

## MSW2040-204 Electrical Specifications

$Z_0 = 50\ \Omega$ , PIN = 0 dBm,  $T_A = 25\ ^\circ\text{C}$  (Unless Otherwise Defined)

Parameter	Symbol	Test Conditions	Minimum Value	Typical Value	Maximum Value	Units
Frequency	F		50	---	1000	MHz
Insertion Loss	IL	Bias state 1: port J0 to J1 Bias state 2: port J0 to J2	---	0.2	0.3	dB
Return Loss	RL	Bias state 1: port J0 and J1 Bias state 2: port J0 and J2	18	20	---	dB
Isolation	Isol	Bias state 1: port J0 to J2 Bias state 2: port J0 to J1	47	50	---	dB
CW Incident Power (Note 2)	Pinc(CW)	Source & load VSWR = 1.5:1	---	---	52	dBm
Peak Incident Power (Note 2)	Pinc(Pk)	Source & load VSWR = 1.5:1, pulse width = 10 $\mu\text{s}$ , duty cycle = 1 %	---	---	57	dBm
Switching Time	$t_{\text{SW}}$	10% -90% RF voltage, TTL rep rate = 100 kHz	---	2	3	$\mu\text{s}$
Input 3rd Order Intercept Point	IIP3	F1 = 500 MHz, F2 = 510 MHz, P1 = P2 = 10 dBm, measured on path biased to low loss state	60	65	---	dBm

# SP2T PIN Diode Switches



## MSW2041-204 Electrical Specifications

$Z_0 = 50 \Omega$ , PIN = 0 dBm,  $T_A = 25 \text{ }^\circ\text{C}$  (Unless Otherwise Defined)

Parameter	Symbol	Test Conditions	Minimum Value	Typical Value	Maximum Value	Units
Frequency	F		400	---	4000	MHz
Insertion Loss	IL	Bias state 1: port J0 to J1 Bias state 2: port J0 to J2	---	0.5	0.7	dB
Return Loss	RL	Bias state 1: port J0 and J1 Bias state 2: port J0 and J2	14	15	---	dB
Isolation	Isol	Bias state 1: port J0 to J2 Bias state 2: port J0 to J1	30	33	---	dB
CW Incident Power (Note 2)	Pinc(CW)	Source & load VSWR = 1.5:1	---	---	52	dBm
Peak Incident Power (Note 2)	Pinc(Pk)	Source & load VSWR = 1.5:1, pulse width = 10 $\mu\text{s}$ , duty cycle = 1 %	---	---	57	dBm
Switching Time	$t_{\text{SW}}$	10% -90% RF voltage, TTL rep rate = 100 kHz	---	2	3	$\mu\text{s}$
Input 3rd Order Intercept Point	IIP3	F1 = 2.00 GHz, F2 = 2.01 GHz, P1 = P2 = 10 dBm, measured on path biased to low loss state	60	65	---	dBm

### Conditions:

1. State 1 (J0 – J1 in low insertion loss state, J0 – J2 in isolation state):
  - a. B1:  $V_{\text{HIGH}}$  (note 2), 0 mA
  - b. B2: -25 mA, 0 V
  - c. J1: -150 mA, 0 V
  - d. J2: 25 mA,  $V_{\text{HIGH}}$  (note 2)
  - e. J0: 150 mA, ~ 0.9 V
2. State 2 (J0 – J2 in low insertion loss state, J0 – J1 in isolation state):
  - a. B1: -25 mA, 0 V
  - b. B2:  $V_{\text{HIGH}}$  (note 2), 0 mA
  - c. J1: 25 mA,  $V_{\text{HIGH}}$  (note 2)
  - d. J2: -150 mA, 0 V
  - e. J0: 150 mA, ~0.9 V

### Electrical Specifications Notes:

1. Switching time ( 50 % TTL – 10/90 % RF Voltage ) is a function of the PIN diode driver performance as well as the characteristics of the diode. An RC “current spiking network” is used on the driver output to provide a transient current to rapidly remove stored charge from the PIN diode. Typical component values are: R = 50 to 220  $\Omega$  and C = 470 to 1,000 pF. Aeroflex/Metelics MPD2T28125-700 is the recommended PIN diode driver to interface with the MSW2040-204 and MSW2041-204 SP2T switches. Its data sheet is available at (<http://www.aeroflex.com/metelics>).
2. PIN diode minimum reverse DC voltage ( $V_{\text{HIGH}}$ ) to maintain high resistance in the OFF PIN diode is determined by RF frequency, incident power, duty cycle, characteristic impedance and VSWR as well as by the characteristics of the diode. The recommended minimum reverse bias voltage ( $V_{\text{HIGH}}$ ) values are provided in the Minimum Reverse Bias Voltage table (page 9) of this datasheet.

## Absolute Maximum Ratings

$T_A = +25\text{ }^\circ\text{C}$ ,  $Z_0 = 50\ \Omega$  (Unless Otherwise Defined)

Parameter	Conditions	Absolute Maximum Value
Forward Current J0, J1, J2		250 mA
Forward Current B1, B2		100 mA
Reverse Voltage J0, J1, J2, B1, B2		200 V
Forward Diode Voltage	$I_F = 250\text{ mA}$	1.2 V
Operating Temperature		-65 °C to 125 °C
Storage Temperature		-65 °C to 150 °C
Junction Temperature		175 °C
Assembly Temperature	$t = 10\text{ s}$	260 °C for 10 s
CW Incident Power Handling J0, J1, J2 (Note 1)	Source & load VSWR = 1.5 :1, $T_{CASE} = 85\text{ }^\circ\text{C}$ , cold switching	51 dBm
Peak Incident Power Handling J0, J1, J2 (Note 1))	Source & load VSWR = 1.5 :1, $T_{CASE} = 85\text{ }^\circ\text{C}$ , cold switching, pulse width = 10 $\mu\text{s}$ , duty cycle = 1 %	57 dBm
Total Dissipated RF & DC Power (Note 1)	$T_{CASE} = 85\text{ }^\circ\text{C}$ , cold switching	6 W

### Notes:

1. Backside RF and DC grounding area of device must be completely solder-attached to RF circuit board vias for proper electrical and thermal circuit grounding.

# SP2T PIN Diode Switches



## MSW2040-204 Small Signal Typical Performance

$T_A = +25\text{ }^\circ\text{C}$ ,  $Z_0 = 50\text{ }\Omega$  (Unless Otherwise Defined)

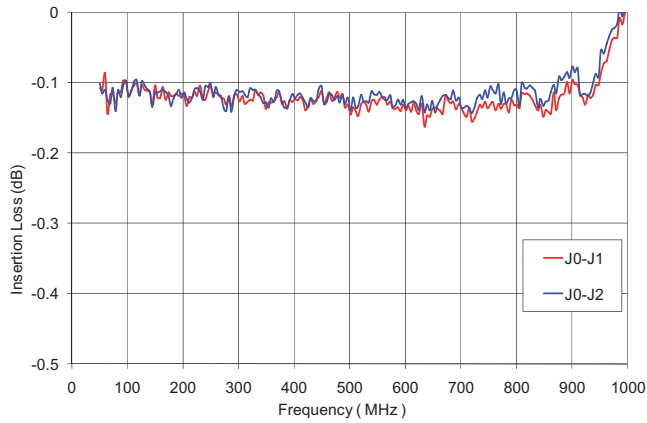

MSW2040-204 Insertion Loss

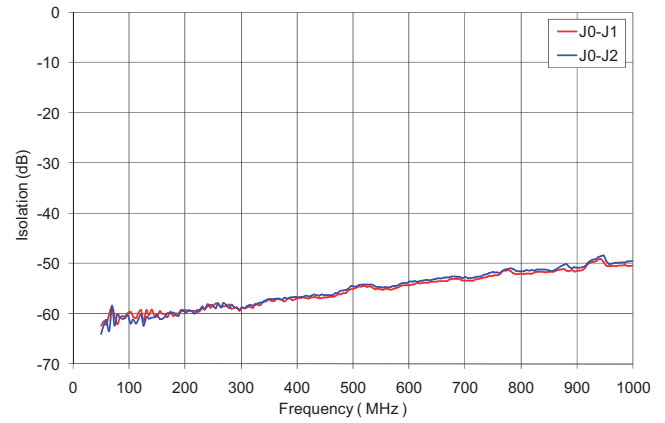

MSW2040-204 Isolation

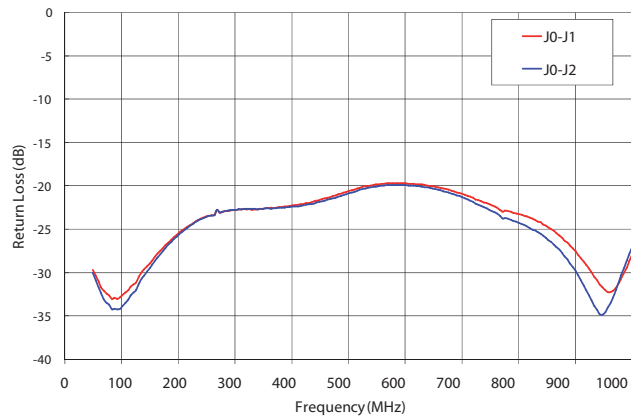

MSW2040-204 Return Loss

## MSW2041-204 Small Signal Typical Performance

$T_A = +25\text{ }^\circ\text{C}$ ,  $Z_0 = 50\ \Omega$  (Unless Otherwise Defined)

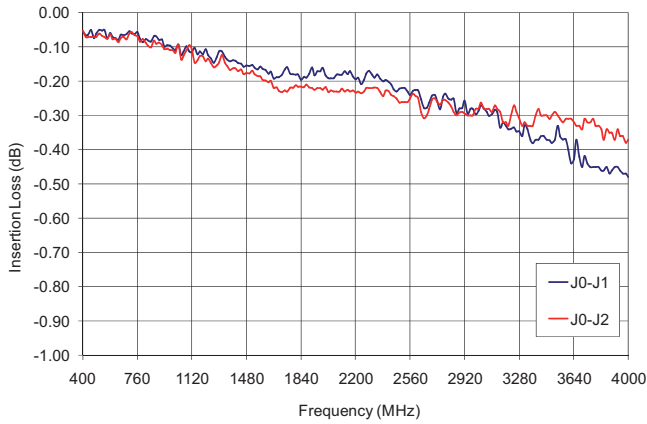

MSW2041-204 Insertion Loss

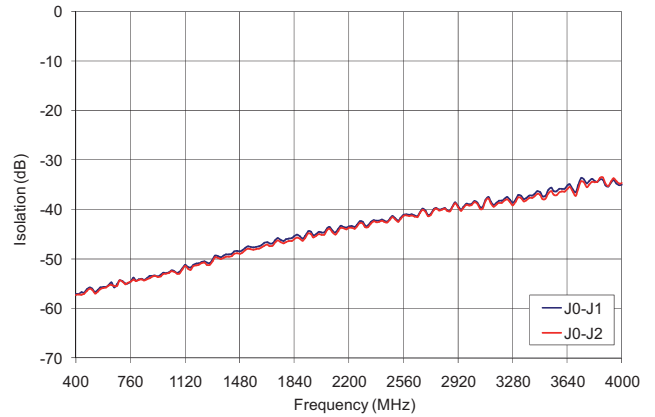

MSW2041-204 Isolation

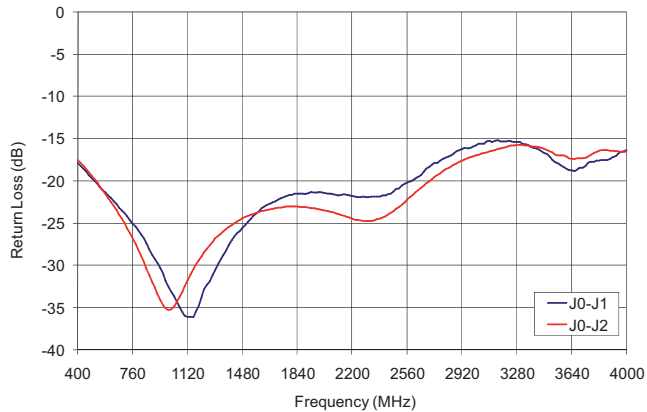

MSW2041-204 Return Loss

# SP2T PIN Diode Switches

## SP2T Switch Evaluation Board Schematic

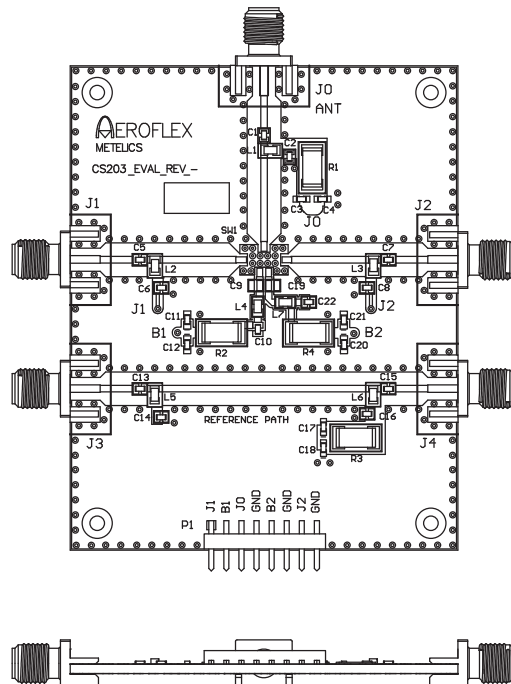
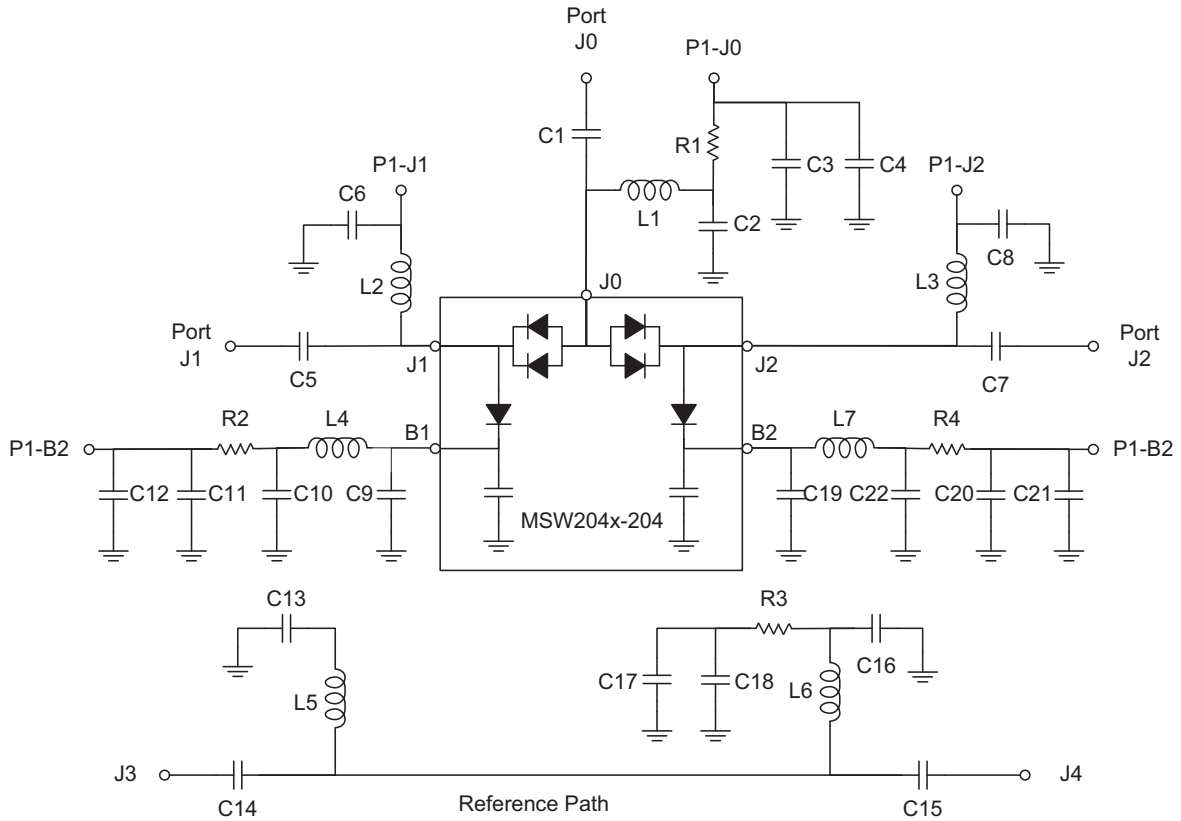

## Evaluation Board Description

The evaluation boards for the MSW204x family of surface mount silicon PIN diode SP2T T-R switches allow the full exercise of each switch for small signal performance analysis, as well as for large signal operation with maximum input signal power of 45 dBm (CW or peak power). Each evaluation board includes the appropriate MSW204x-204 switch, DC blocking capacitors at each RF port and bias decoupling networks at each RF port which allow DC or low frequency control signals to be applied to the switch.

Four complementary control signals are required for proper operation. Bias voltages are applied to the B1 and B2 bias ports, as well as to the J0, J1 and J2 RF ports to control the state of the switch. A fixed bias voltage must be applied to the J0 port (connect 5 V to pin 3 of multi-pin connector P1) whenever the switch is in operation.

**Caution: the evaluation board, as supplied from the factory, is not capable of handling RF input signals larger than 45 dBm.** If performance of the switch under larger input signals is to be evaluated several of the passive components on the board must be changed in order to safely handle the dissipated power as well as the high bias voltage necessary for proper performance. The evaluation board must be connected to an adequate heat sink for large signal operation. Contact the factory for recommended components.

For the purposes of description, State 1 is defined to be the condition in which the evaluation board is biased to produce the low insertion condition between ports J0 and J1 while producing high isolation between ports J0 and J2. State 2 is the converse of State 1.

### State 1

In State 1, the series PIN diode between the J0 and J1 ports is forward biased by applying 0 V to the J1 bias input port (pin 1 of multi-pin connector P1). The magnitude of the resultant bias current through the diode is primarily determined by the voltage applied to the J0 bias port (pin 3 of P1), the magnitude of the forward voltage across the PIN diode and the resistance of R1. This current is nominally 150 mA. At the same time, the PIN diode connected between J2 and B2 ports is also forward biased by applying a high bias voltage, nominally 28 V, to the J2 bias port (pin 7 of P1) and 0 V to the B2 bias port (pin 5 of P1). Under this condition, the PIN diode connected between the J0 and J2 ports is reverse biased and the PIN diode connected between the J2 and B2 ports is forward biased. The magnitude of the bias current through this diode is primarily determined by the voltage applied to the J2 bias port, the magnitude of the forward voltage across the PIN diode and the resistance of R4. This current is nominally 25 mA.

The series PIN diode which is connected between the J0 and J2 ports must be reverse biased during State 1. The reverse bias voltage must be sufficiently large to maintain the diode in its non-conducting, high impedance state when large RF signal voltage may be present in the J0-to-J1 path. The reverse voltage across this diode is the arithmetic difference of the bias voltage applied to the J2 bias port and the DC forward voltage of the forward-biased J0-to-J1 series PIN diode.

The minimum voltage required to maintain the series diode between J0 and J2 out of conduction is a function of the magnitude of the RF voltage present, the standing wave present at the series diode's anode, the frequency of the RF signal and the characteristics of the series diode, among other factors. Minimum control voltages for several signal frequencies are shown in the table "Minimum Reverse Bias Voltage", assuming the input power to the J0 or J1 port to be 100 W CW and the VSWR on the J0-J1 path to be 1.5:1.

### State 2

In the State 2, the series PIN diode between the J0 and J2 ports is forward biased by applying 0 V to the J2 bias input port (pin 7 of multi-pin connector P1). The magnitude of the resultant bias current through the diode is primarily determined by the voltage applied to the J0 bias port (pin 3 of P1), the magnitude of the forward voltage across the PIN diode and the resistance of R1. This current is nominally 150 mA. At the same time, the PIN diode connected between J2 and B2 ports is reverse biased by applying a high bias voltage, nominally 28 V, to the B2 bias port (pin 5 of P1). A high voltage, nominally 28 V, is also applied to the J1 bias port (pin 1 of P1). Under this condition, the PIN diode connected between the J0 and J1 ports is reverse biased thus isolating the J1 RF port from the RF signal path between J0 and J2. The reverse voltage across this diode is the arithmetic difference of the bias voltage applied to the J1 bias port and the DC forward voltage of the forward-biased J0-to-J2 series PIN diode. The minimum voltage required to maintain the series diode on the J0-to-J1 side of the switch out of conduction is a function of the magnitude of the RF voltage present, the standing wave present at the diode's anode, the frequency of the RF signal and the characteristics of the series diode, among other factors.

The values of the reactive components which comprise the bias decoupling networks as well as the signal path DC blocking are shown in the table RF Bias Network Recommended Component Values.



# SP2T PIN Diode Switches



## Reference Path

A reference path is provided on the evaluation board, complete with bias decoupling networks, so that the magnitude of the insertion loss of the microstrip transmission lines connected to the switch and the associated bias decoupling components can be measured and removed from the measured performance of the switch.

## RF Bias Network Recommended Component Values

Part Number	F ( MHz )	DC Blocking Capacitors	Inductors	RF Bypass Capacitors
MSW2040-204	50 – 1,000	0.1 $\mu$ F	4.7 $\mu$ H	0.1 $\mu$ F
MSW2041-204	400 – 4,000	27 pF	82 nH	270 pF

## Minimum Reverse Bias Voltage

$P_{IN} = 125$  W CW, VSWR = 1.5:1,  $Z_0 = 50 \Omega$

Part Number	F = 50 MHz	F = 100 MHz	F = 200 MHz	F = 400 MHz	F = 1 GHz	F = 4 GHz
MSW2040-204	125 V	125 V	85 V	55 V	28 V	NA
MSW2041-204	NA	NA	125 V	85 V	55 V	28 V

Notes:

1. " NA " denotes the switch is not recommended for operation in that frequency band.

## Assembly Instructions

The MSW2040-204 and MSW2041-204 switches are capable of being placed onto circuit boards with pick and place manufacturing equipment from tube or tape-reel dispensing. The devices are attached to the circuit board using conventional solder re-flow or wave soldering procedures with RoHS type or Sn60/Pb40-type solders per Table 1 and Figure 1.

Table 1: Time-Temperature Profile for Sn 60/Pb40 or RoHS Type Solders

Profile Feature	SnPb Solder Assembly	Pb-Free Solder Assembly
Average ramp-up rate ( $T_L$ to $T_P$ )	3°C/second maximum	3°C/second maximum
Preheat - Temperature Minimum ( $T_{SMIN}$ ) - Temperature Maximum ( $T_{SMAX}$ ) - Time (Minimum to maximum) ( $t_S$ )	100°C 150°C 60-120 seconds	150°C 200°C 60-180 seconds
$T_{SMAX}$ to $T_L$ - Ramp-up Rate		3°C/second maximum
Time Maintained above: - Temperature ( $T_L$ ) - Time ( $t_L$ )	183°C 60-150 seconds	217°C 60-150 seconds
Peak Temperature ( $T_P$ )	225 +0 / -5°C	260 +0/-5°C
Time within 5°C of actual Peak Temperature ( $T_P$ )	10-30 seconds	20-40 seconds
Ramp-down Rate	6°C/second maximum	6°C/second maximum
Time 25°C to Peak Temperature	6 minutes maximum	8 minutes maximum

Figure 1: Solder Re-Flow Time-Temperature Profile

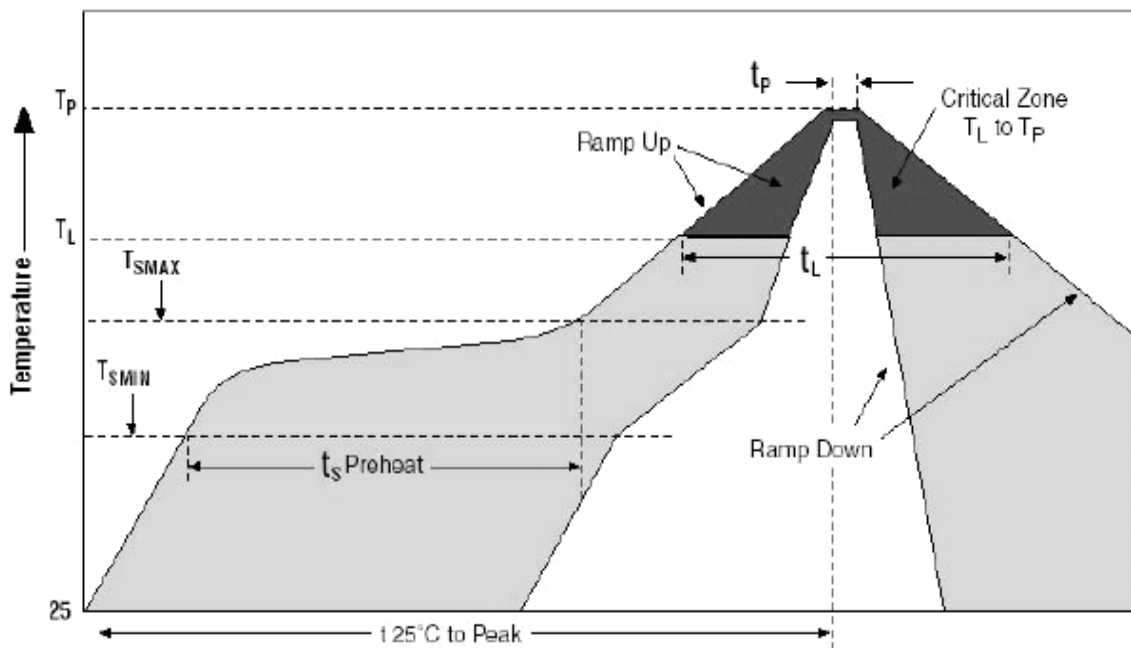

# SP2T PIN Diode Switches



## MSW2040-204 & MSW2041-204 SP2T Switch Outline ( Case Style 204 )

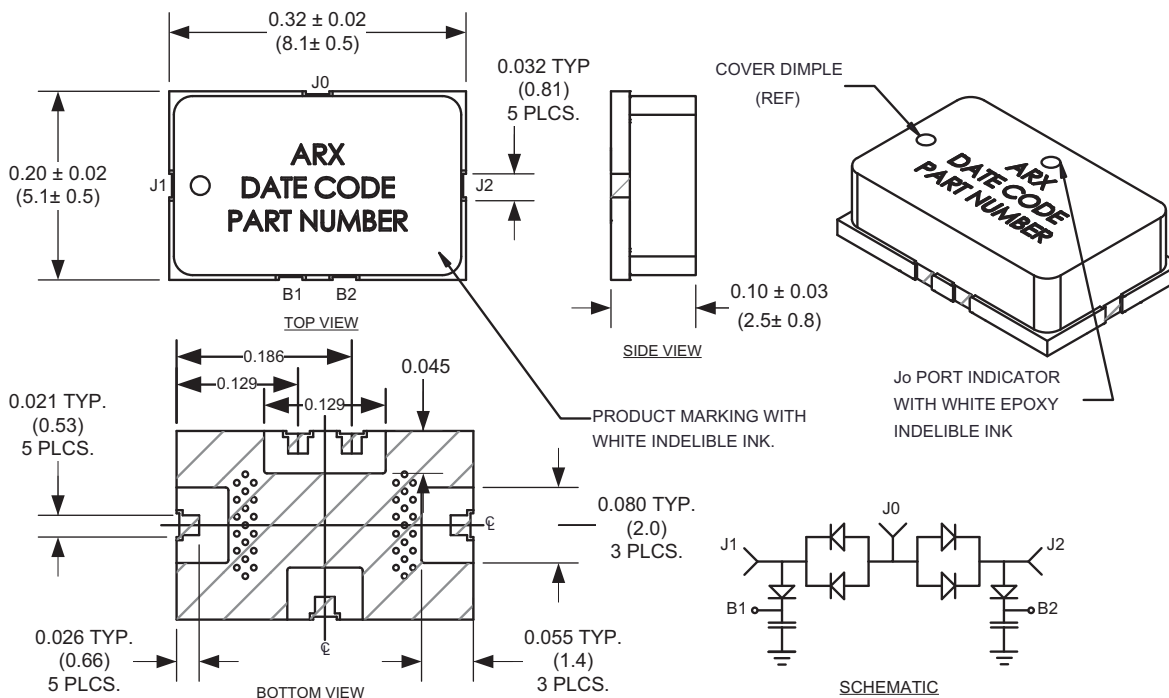

**NOTES:**

1. SUBSTRATE MATERIAL: 20 MIL THICK ALUMINUM NITRIDE (ALN) RF COVER: BLACK CERAMIC.
2. TOP SIDE AND BACKSIDE METALLIZATION: 40µ IN PLATED Au, 60µ IN PLATED Ni OVER Ti-Pd-Au.
3. DIMENSION IN PARENTHESIS ARE IN MM.

Note: Hatched Metal Area on Circuit Side of Device is RF and DC and thermal ground.

## RF Circuit Solder Footprint for Case Style 204 ( CS204 )

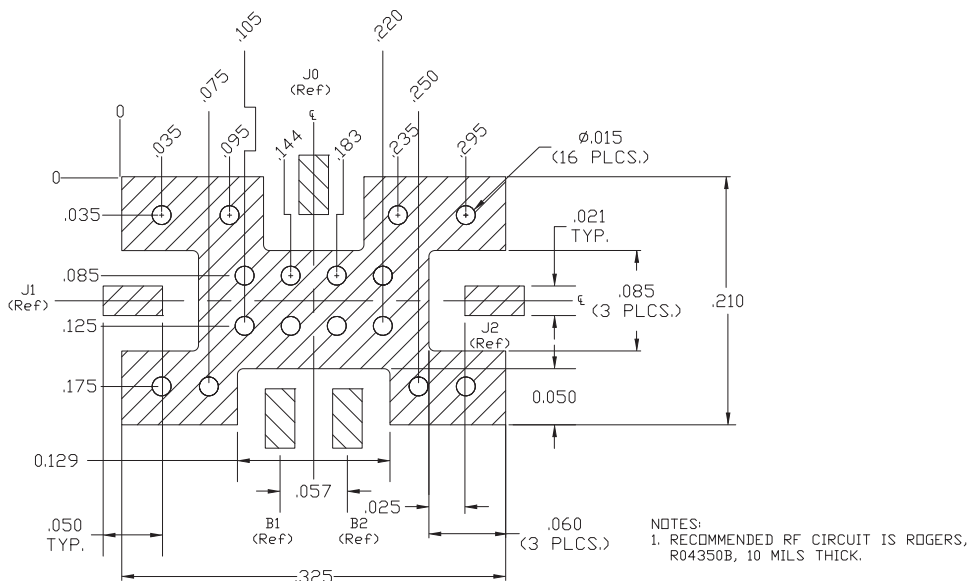

Hatched Area is RF, D.C., and Thermal Ground. Vias should be solid copper fill and gold plated for optimum heat transfer from backside of switch module through Circuit Vias to metal thermal ground.

**Part Number Ordering Information:**

Part Number	Packaging
MSW2040-204-T	Tube
MSW2040-204-R	Tape-Reel (Quantities of 250 or 500)
MSW2040-204-W	Waffle Pack
MSW2041-204-T	Tube
MSW2041-204-R	Tape-Reel (Quantities of 250 or 500)
MSW2041-204-W	Waffle Pack
MSW2040-204-E	RF Evaluation Board
MSW2041-204-E	RF Evaluation Board

**Aeroflex / Metelics, Inc.**

**ISO 9001:2008 certified companies**

54 Grenier Field Road, Londonderry, NH 03053  
Tel: (603) 641-3800  
Sales: (888) 641-SEMI (7364)  
Fax: (603)-641-3500

975 Stewart Drive, Sunnyvale, CA 94085  
Tel: (408) 737-8181  
Fax: (408) 733-7645

[www.aeroflex.com/metelics](http://www.aeroflex.com/metelics)      [metelics-sales@aeroflex.com](mailto:metelics-sales@aeroflex.com)

Aeroflex / Metelics, Inc. reserves the right to make changes to any products and services herein at any time without notice. Consult Aeroflex or an authorized sales representative to verify that the information in this data sheet is current before using this product. Aeroflex does not assume any responsibility or liability arising out of the application or use of any product or service described herein, except as expressly agreed to in writing by Aeroflex; nor does the purchase, lease, or use of a product or service from Aeroflex convey a license under any patent rights, copyrights, trademark rights, or any other of the intellectual rights of Aeroflex or of third parties.

Copyright 2012 Aeroflex / Metelics. All rights reserved.



Our passion for performance is defined by three attributes represented by these three icons: solution-minded, performance-driven and customer-focused.