

SP2T Switch-Limiter

MSWLM2402-242 Datasheet



Features

- Surface Mount SP2T Switch-Limiter in Compact Outline: 8 mm L x 5 mm W x 2.5 mm H
- Wide operating frequency range: 2 to 4 GHz
- Higher Average Power Handling than Plastic Packaged Switch: 125 W CW
- High Voltage Rating (> 500 V) for High RF Peak Power
- Low Insertion Loss: 0.85 dB
- Low VSWR: 1.6:1
- Operates from 5 V, 30 V & -5 V Supplies
- RoHS Compliant



Applications

- Active and passive receiver protection, 2 to 4 GHz
- High power transmit/receive switching with passive receiver protection, 2 to 4 GHz

Description

The MSWLM2420-242 SP2T Switch-Limiter Module incorporates a high-power SP2T switch with a passive limiter and a fully integrated DC bias network. It is designed to be used in high power switch applications operating from 2 to 4 GHz.

The MSWLM2420-242 is manufactured using Aeroflex / Metelics proven hybrid manufacturing process incorporating high voltage PIN diodes and passive devices integrated within a ceramic substrate. This low profile, compact, surface mount component, (8 mm L x 5 mm W x 2.5 mm H) offers superior large and small signal performance comparable to that of MMIC devices in QFN packages. The SP2T Switch-Limiter is designed to minimize Ant-Rx insertion loss in the small-signal receive state and to provide excellent input return loss in the Tx-Ant signal path under large signal (51 dBm CW) conditions while in the transmit state.

The very low thermal resistance (< 40 °C/W) of the PIN diodes in this device enable it to reliably handle RF incident power levels of 51 dBm CW and RF peak incident power levels of 53 dBm in cold switching applications at $T_A = 85$ °C. The PIN limiter diode low series resistance (< 1.5 Ω) produces low flat leakage power (15 dBm), and its small capacitance (< 0.15 pF) produces very low insertion loss (< 1 dB). This switch-limiter is designed for systems which utilize high volume, surface mount, solder re-flow assembly manufacturing. This product is durable and capable of reliably operating in military, commercial, and industrial environments. It is RoHS compliant.

Environmental Capabilities

The MSWLM2420-242 Switch-Limiter Module is capable of meeting the environmental requirements of MIL-STD-202 and MIL-STD-750. The package uses a moisture seal enclosure.

ESD and Moisture Sensitivity Level Rating

PIN diode switches are susceptible to damage from ESD events, as are all semiconductors. The ESD rating for this device is Class 1A, HBM. The moisture sensitivity level rating for this device is MSL 1.



MSWLM2420-242 Switch-Limiter Pinout

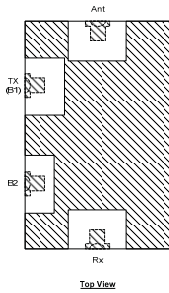

MSWLM2420-242 Electrical Specifications

@ $Z_0 = 50 \Omega$, $T_A = +25 \text{ }^\circ\text{C}$, as measured in Aeroflex Metelics evaluation board (Unless Otherwise Defined)

Parameter	Symbol	Test Conditions	Minimum Value	Typical Value	Maximum Value	Units
Frequency	F		2	---	4	GHz
Ant-Tx Return Loss	RL (Tx)	Condition 1	12	20	---	dB
Ant-Rx Insertion Loss	IL (Rx)	Condition 2	---	0.7	1.7	dB
Ant-Tx Insertion Loss	IL (Tx)	Condition 1	---	0.25	0.35	dB
Ant-Rx Return Loss	RL (Rx)	Condition 2	13.0	15.0	---	dB
Ant-Rx Isolation	Isol (Rx)	Condition 1	35	40	---	dB
Tx Incident Power	P_{inc} (TxCW)	Condition 1	---	---	51.0	dBm
Switching Time	T_{SW}	Conditions 1, 2, 3, 50% TTL to 90% RF Voltage	---	500	700	ns
Ant-Rx Input Power	P_{inc} (Rx)	Condition 4	---	---	33.0	dBm
Flat Leakage Power	FL	Condition 3, $f = 2.45 \text{ GHz}$	---	13.0	15.0	dBm
Spike Leakage Energy	SL	Condition 3	---	0.1	0.2	erg
Recovery Time	T_R	Condition 3, Insertion Loss = 1 dB	---	700	1000	ns

MSWLM2420-242 Electrical Specifications

@ $Z_0 = 50 \Omega$, $T_A = +25 \text{ }^\circ\text{C}$, as measured in Aeroflex / Metelics evaluation board (Unless Otherwise Defined)

Parameter	Symbol	Test Conditions	Minimum Value	Typical Value	Maximum Value	Units
Frequency	F		3.1	---	3.5	GHz
Ant-Tx Return Loss	RL (Tx)	Condition 1	13.0	16.0	---	dB
Ant-Rx Insertion Loss	IL (Rx)	Condition 2	---	0.85	1.00	dB
Ant-Tx Insertion Loss	IL (Tx)	Condition 1	---	0.25	0.35	dB
Ant-Rx Return Loss	RL (Rx)	Condition 2	13.0	15.0	---	dB
Ant-Rx Isolation	Isol (Rx)	Condition 1	40.0	45.0	---	dB
Tx Incident Power	P_{inc} (TxCW)	Condition 1	---	---	51.0	dBm
Switching Time	T_{SW}	Conditions 1, 2, 3, 50% TTL to 90% RF Voltage	---	500	700	ns
Ant-Rx Input Power	P_{inc} (Rx)	Condition 4	---	---	33.0	dBm
Flat Leakage Power	FL	Condition 3, $f = 2.45 \text{ GHz}$	---	13.0	15.0	dBm
Spike Leakage Energy	SL	Condition 3	---	0.1	0.2	erg
Recovery Time	T_R	Condition 3, Insertion Loss = 1 dB	---	700	1000	ns

MSWLM2420-242 Electrical Specifications

@ $Z_0 = 50 \Omega$, $T_A = +85^\circ\text{C}$ or -54°C , as measured in Aeroflex / Metelics evaluation board (Unless Otherwise Defined)

Parameter	Symbol	Test Conditions	Minimum Value	Typical Value	Maximum Value	Units
Frequency	F		3.1	---	3.5	GHz
Ant-Tx Return Loss	RL (Tx)	Condition 1	13.0	16.0	---	dB
Ant-Rx Insertion Loss	IL (Rx)	Condition 2	---	1.00	1.20	dB
Ant-Tx Insertion Loss	IL (Tx)	Condition 2	---	0.30	0.40	dB
Ant-Rx Return Loss	RL (Rx)	Condition 2	13.0	15.0	---	dB
Ant-Rx Isolation	Isol (Rx)	Condition 1	40.0	43.0	---	dB
Tx Incident Power	P_{inc} (TxCW)	Condition 1	---	---	51.0	dBm
Switching Time	T_{SW}	Conditions 1, 2, 3, 50% TTL to 90% RF Voltage	---	500	700	ns
Ant-Rx Input Power	P_{inc} (Rx)	Condition 4	---	---	33.0	dBm
Flat Leakage Power	FL	Condition 3	---	13.0	15	dBm
Spike Leakage Energy	SL	Condition 3	---	0.1	0.2	erg
Recovery Time	T_R	Condition 3, Insertion Loss = 1 dB	---	700	1000	ns

Conditions:

1. Tx – Ant High Power Transmit State:
 - a. Input signal: 125 W @ 300 μs pulse width and 10% duty cycle, or 100 μs pulse width and 20% duty cycle
 - b. Source/load VSWR $\leq 1.2:1$
 - c. DC bias: 30 V @ approximately 130 mA (B1), -1 V @ approximately -25 mA (B2)
2. Ant-Rx Small Signal Receive State:
 - a. Input signal: -10 dBm
 - b. Source/load VSWR $\leq 1.2:1$
 - c. DC bias: -5 V @ 0 mA (B1), 4.7 V @ approximately 20 mA (B2)
3. Ant-Rx Large Signal Receiver-Protection State:
 - a. Input signal: 33 dBm CW
 - b. Source/load VSWR $\leq 1.2:1$.
 - c. DC bias: -5 V @ 0 mA (B1), 4.7 V @ approximately 20 mA (B2).
4. Ant-Rx Moderate Power Receiver-Protection State:
 - a. Source/Load VSWR = 1.2:1
 - b. Input signals: unsynchronized, 33 dBm CW
 - c. DC Bias: OFF

SP2T Switch-Limiter Schematic

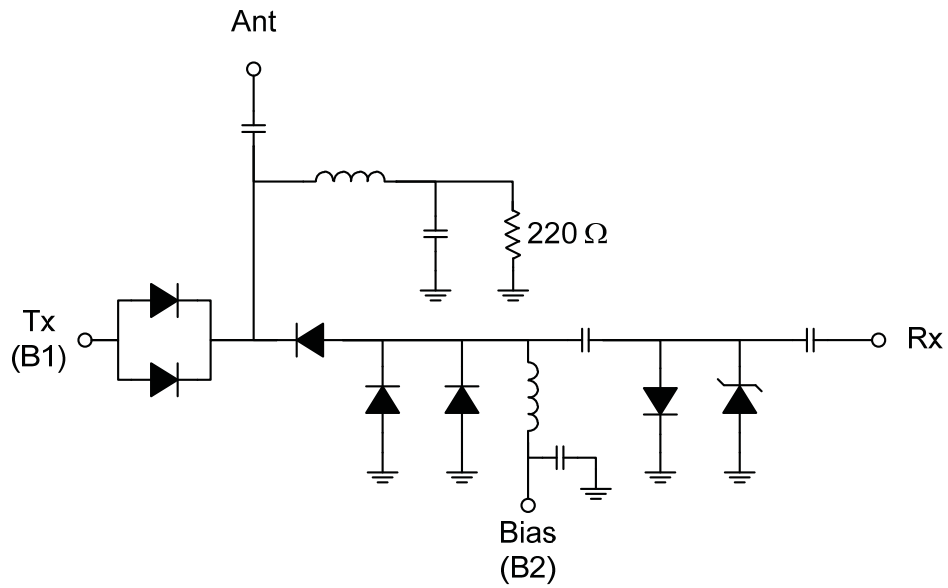

Truth Table

Ant – Tx Path	Ant – Rx Path	B1 Bias	B2 Bias
Low insertion loss	Isolation	30 V (nominal) @ 130 mA	-5 V (nominal) @ -25 mA
Isolation	Low insertion loss, small RF input signal	-5 V @ 0 mA	5 V (nominal) @ 20 mA

SP2T Switch-Limiter



Typical Performance

$Z_0 = 50 \Omega$, $T_A = 25 \text{ }^\circ\text{C}$ (Unless Otherwise Defined)

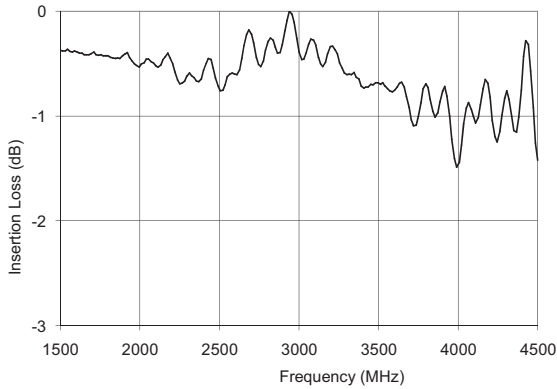

Insertion Loss, ANT-to-RX, $P_{IN} = -10 \text{ dBm}$, Condition 2

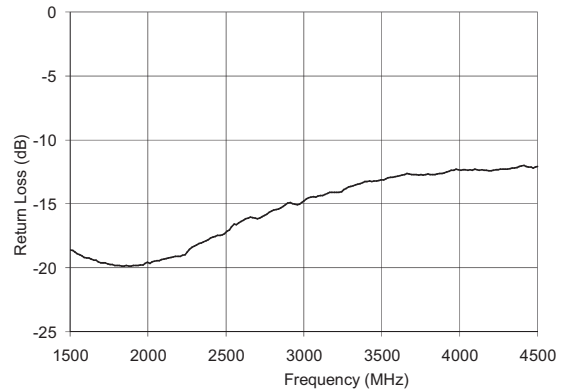

Return Loss, ANT-to-RX, $P_{IN} = -10 \text{ dBm}$, Condition 2

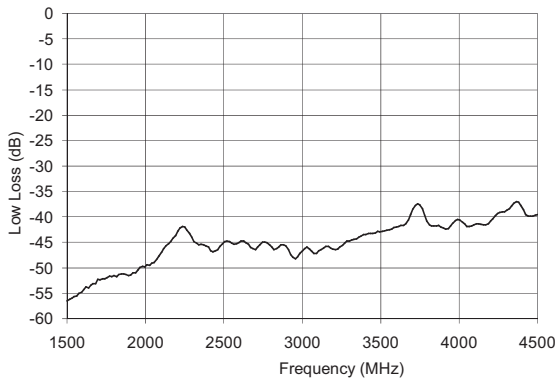

Isolation, ANT-to-RX, $P_{IN} = -10 \text{ dBm}$, Condition 1

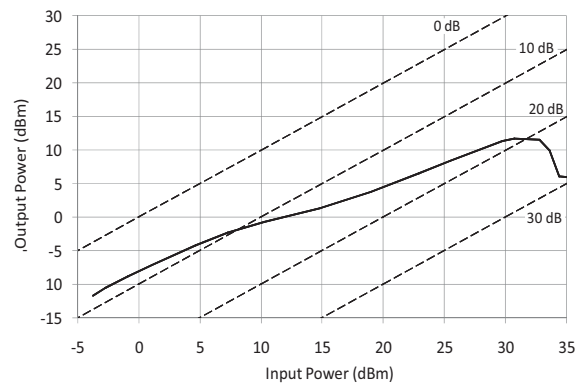

Output Power vs. Input Power, ANT to RX, Condition 2, $f = 3.1 \text{ GHz}$

Typical Performance

$Z_0 = 50 \Omega$, $T_A = 25 \text{ }^\circ\text{C}$ (Unless Otherwise Defined)

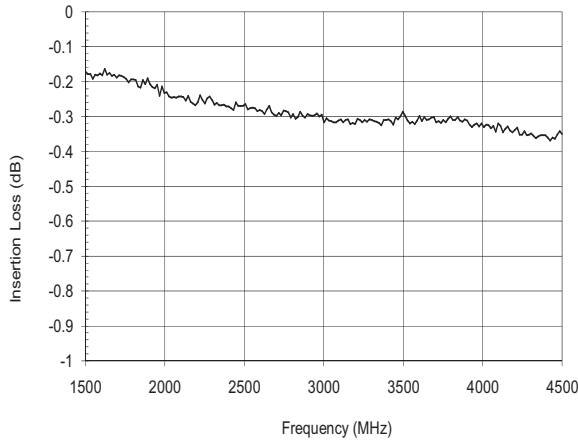

Insertion Loss, TX-to-ANT, $P_{IN} = -10 \text{ dBm}$, Condition 1

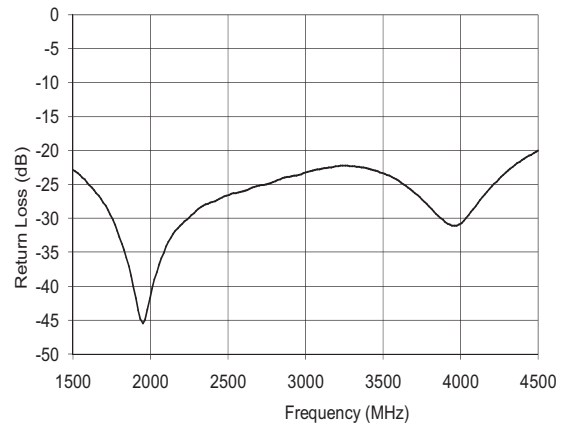

Return Loss, TX-to-ANT, $P_{IN} = -10 \text{ dBm}$, Condition 1

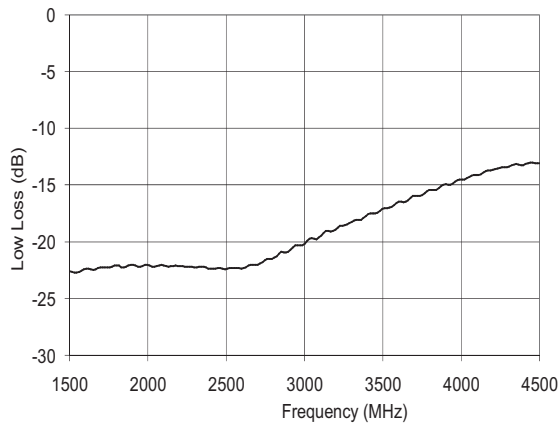

Isolation, TX-to-ANT, $P_{IN} = -10 \text{ dBm}$, Condition 2

SP2T Switch-Limiter Application - Active Receiver Protector

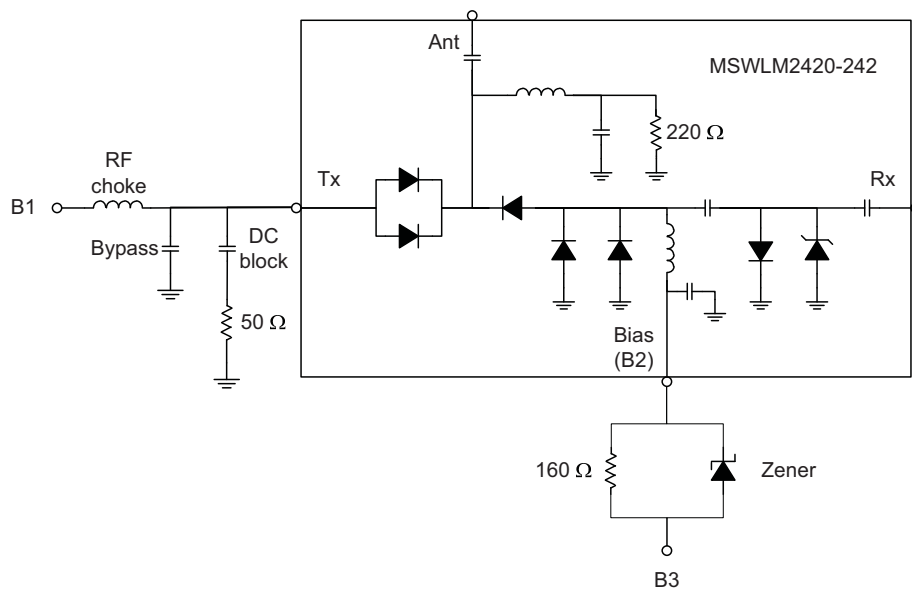

Truth Table – Suggested Application Circuit

Ant – Tx Path	Ant – Rx Path	B1 Bias	B2 Bias	B3 Bias
Low insertion loss	Isolation	30 V (nominal) @ 130 mA (nominal)	-1 V (nominal) @ -25 mA	-5 V @ -25 mA (nominal)
Isolation	Low insertion loss, small RF input signal	-5 V @ 0 mA	4.7 V (nominal) @ 20 mA	5.0 V @ 20 mA (nominal)

SP2T Switch-Limiter Application Description

In the suggested application circuit shown above, the MSWLM2420-242 Switch-Limiter performs active and passive receiver protection. Active receiver protection is effected when the Ant-Tx path is in its low insertion loss state. Large signals incident upon the antenna terminal are directed to the external 50 Ω terminating resistor connected to the Tx port. When the device is biased to produce low insertion loss in the Ant-Rx path, any large signal incident upon the Ant input port will activate the passive limiter circuit comprising the limiter PIN diode and the Schottky diode located at the Rx output port. This passive limiter circuit produces an impedance mismatch in the Ant-Rx signal path which reflects the large incident signal back towards its source.

Absolute Maximum Ratings

$T_A = +25\text{ }^\circ\text{C}$, $Z_0 = 50\ \Omega$ (Unless Otherwise Defined)

Parameter	Absolute Maximum Value
DC Forward Current @ B1	150 mA
DC Reverse Voltage @ B1	-40 V
DC Forward Diode Voltage @ B1 or B2	1.2 V @ 150 mA
Operating Temperature	- 54 °C to +85 °C
Storage Temperature	- 65 °C to +150 °C
Junction Temperature	175 °C
Assembly Temperature	260 °C for 10 s
Peak Incident Power Handling, 300 μ s pulse width, 10 % duty cycle or 100 μ s pulse width, 20 % duty cycle, source and load VSWR = 1.2 :1 maximum	51 dBm @ $T_{CASE} = +85\text{ }^\circ\text{C}$
Thermal Resistance Junction to Package Terminals	45° C/W
Total Dissipated Power	10 W @ $T_{CASE} = +85\text{ }^\circ\text{C}$

Assembly Instructions

The MSWLM2420-242 Switch-Limiter is capable of being placed onto circuit boards with pick and place manufacturing equipment which utilizes tube or tape-reel dispensing. The device is attached to the circuit board using conventional solder re-flow or wave soldering procedures with RoHS-compliant or Sn60/Pb40 solder per the conditions shown in Table 1 and Figure 1.

Table 1: Time-Temperature Profile for Sn 60 / Pb 40 or RoHS Type Solders

Profile Feature	Sn-Pb Solder Assembly	Pb-Free Solder Assembly
Average ramp-up rate (T_L to T_P)	3 °C/second maximum	3 °C/second maximum
Preheat - Temperature Minimum (T_{SMIN}) - Temperature Maximum (T_{SMAX}) - Time (Minimum to maximum) (t_s)	100 °C 150 °C 60-120 seconds	150 °C 200 °C 60-180 seconds
T_{SMAX} to T_L - Ramp-up Rate		3°C/second maximum
Time Maintained above: - Temperature (T_L) - Time (t_L)	183 °C 60-150 seconds	217 °C 60-150 seconds
Peak Temperature (T_P)	225 +0 / -5 °C	260 +0/-5 °C
Time within 5°C of actual Peak Temperature (T_P)	10-30 seconds	20-40 seconds
Ramp-down Rate	6 °C/second maximum	6 °C/second maximum
Time 25°C to Peak Temperature	6 minutes maximum	8 minutes maximum

Figure 1: Solder Re-Flow Time-Temperature Profile

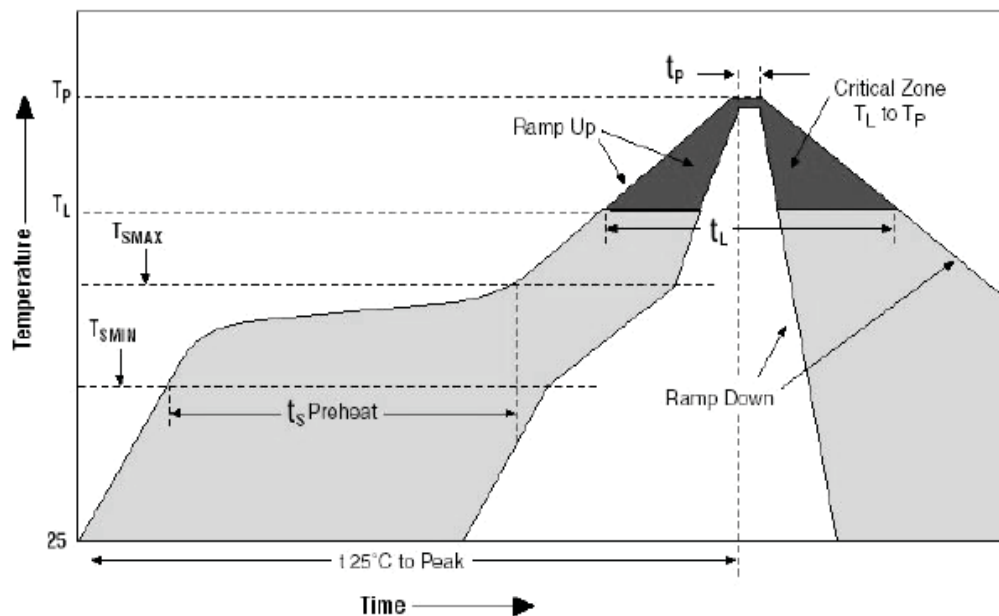

MSWLM2420-242 SP2T Switch-Limiter Outline (Case Style 242)

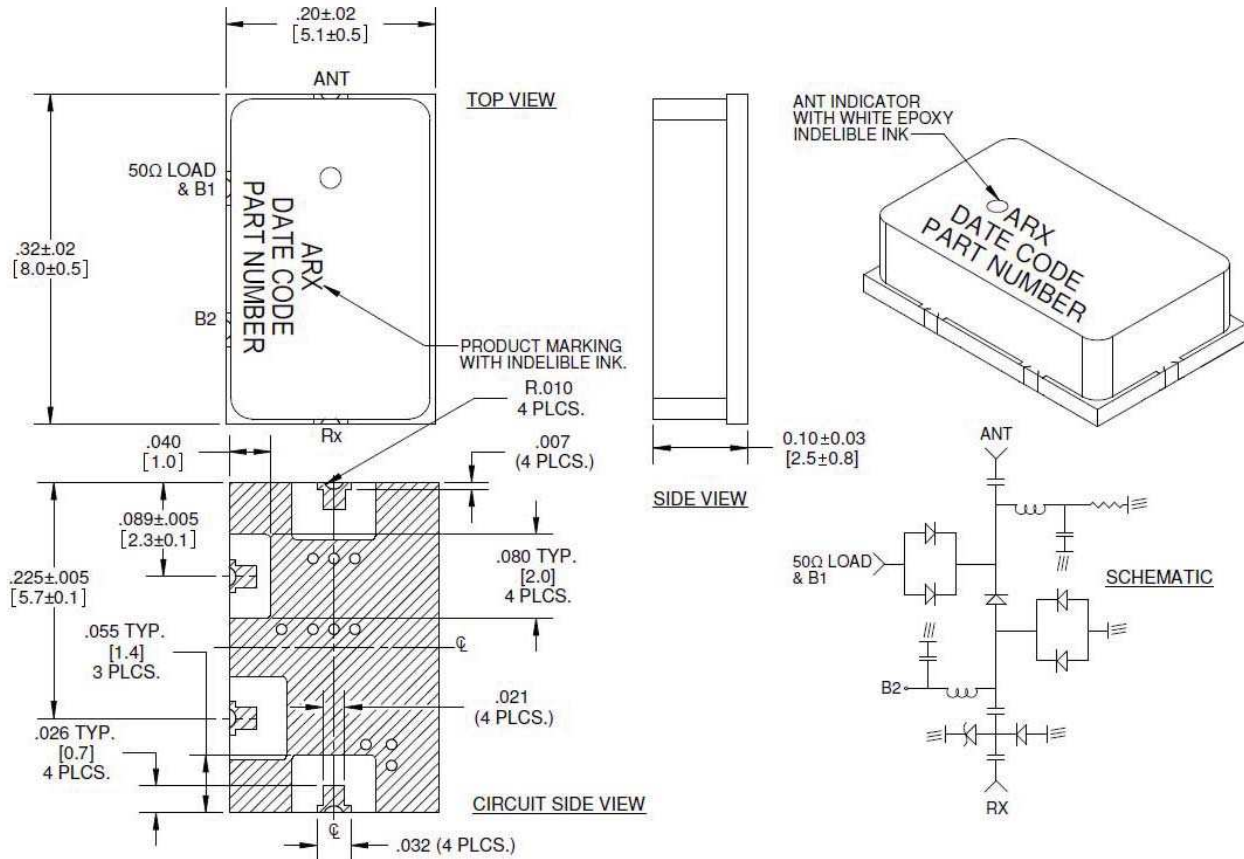

- NOTES:
1. SUBSTRATE MATERIAL: 20 MIL THICK ALUMINA NITRIDE (ALN) RF COVER: BLACK CERAMIC.
 2. TOP SIDE AND BACKSIDE METALLIZATION: 40μ IN PLATED Au, 60μ IN PLATED Ni OVER Ti-Pd-Au.
 3. DIMENSION IN PARENTHESIS ARE IN MM.
 4. SHADED OR HATCHED AREAS DENOTE METALLIZATION.

Note:

The hatched metal area on circuit side of device must be connected via lowest possible impedance to RF and DC ground. It also must be connected via lowest possible thermal impedance to the ambient temperature environment.

SP2T Switch-Limiter

Recommended PCB Footprint for Case Style 242 (CS 242)

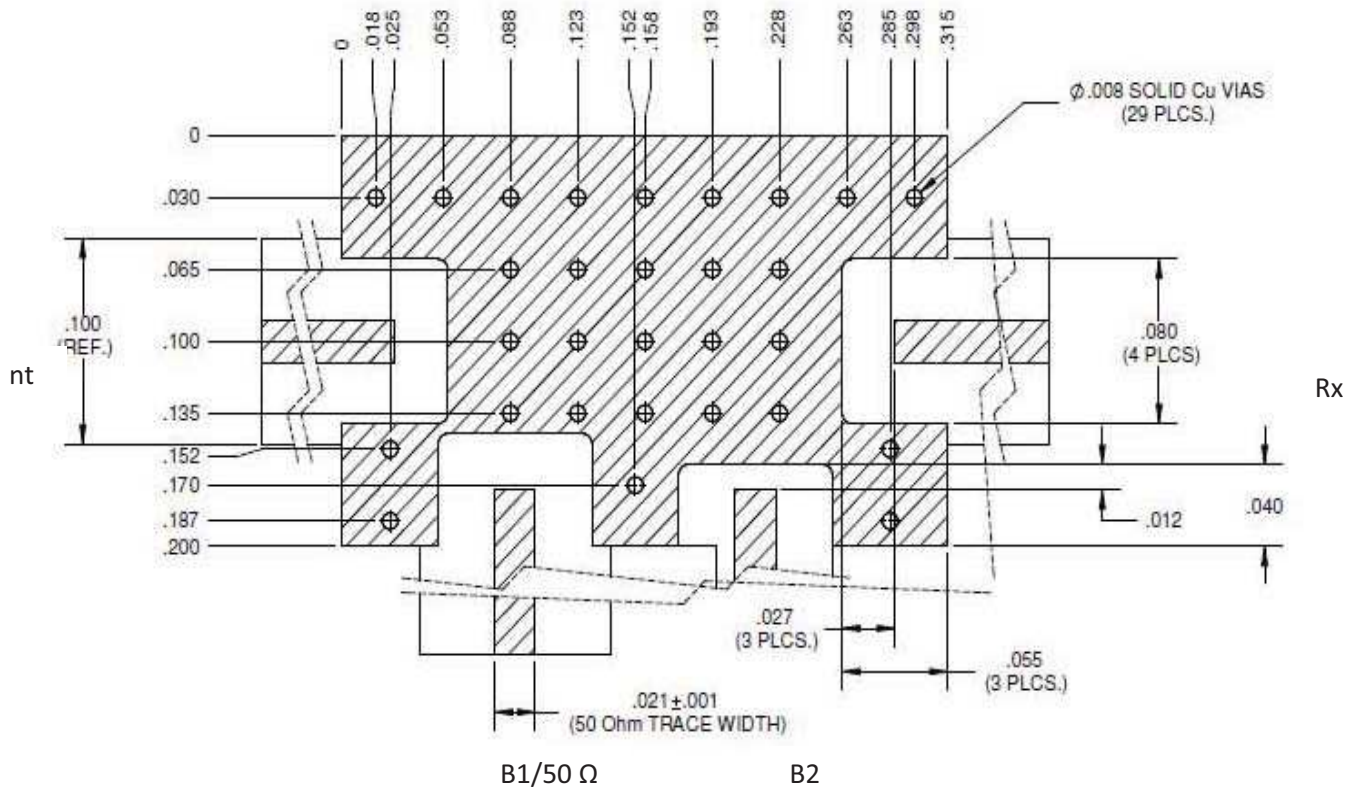

The hatched metal area on circuit side of device must be connected via lowest possible impedance to RF and DC ground. It also must be connected via lowest possible thermal impedance to the ambient temperature. Vias should be solid copper fill and gold plated for optimum heat transfer from backside of limiter module through circuit vias to heat sink on back side of PCB.

Part Number Ordering Information:

Part Number	Packaging
MSWLM2420-242-T	Tube Packaging
MSWLM2420-242-R	Tape-Reel Packaging (Quantity: 250 or 500 modules per reel)
MSWLM2420-242-W	Waffle Packaging

Aeroflex / Metelics, Inc.

54 Grenier Field Road, Londonderry, NH 03053
 Tel: (603) 641-3800
 Sales: (888) 641-SEMI (7364)
 Fax: (603)-641-3500

975 Stewart Drive, Sunnyvale, CA 94085
 Tel: (408) 737-8181
 Fax: (408) 733-7645

www.aeroflex.com/metelics metelics-sales@aeroflex.com

Aeroflex / Metelics, Inc. reserves the right to make changes to any products and services herein at any time without notice. Consult Aeroflex or an authorized sales representative to verify that the information in this data sheet is current before using this product. Aeroflex does not assume any responsibility or liability arising out of the application or use of any product or service described herein, except as expressly agreed to in writing by Aeroflex; nor does the purchase, lease, or use of a product or service from Aeroflex convey a license under any patent rights, copyrights, trademark rights, or any other of the intellectual rights of Aeroflex or of third parties.

Copyright 2012 Aeroflex / Metelics. All rights reserved.

ISO 9001:2008 certified companies



Our passion for performance is defined by three attributes represented by these three icons: solution-minded, performance-driven and customer-focused.