

UT54LVDS217 Serializer

Data Sheet

October 26, 2011

www.aeroflex.com/lvds



FEATURES

- ❑ 15 to 75 MHz shift clock support
- ❑ Low power consumption
- ❑ Power-down mode <math><216\mu\text{W}</math> (max)
- ❑ Cold sparing all pins
- ❑ Narrow bus reduces cable size and cost
- ❑ Up to 1.575 Gbps throughput
- ❑ Up to 197 Megabytes/sec bandwidth
- ❑ 325 mV (typ) swing LVDS devices for low EMI
- ❑ PLL requires no external components
- ❑ Rising edge strobe
- ❑ Operational Environment; total dose irradiation testing to MIL-STD-883 Method 1019
 - Total-dose: 300 krad(Si) and 1 Mrad(Si)
 - Latchup immune (LET > 100 MeV-cm²/mg)
- ❑ Packaging options:
 - 48-lead flatpack
- ❑ Standard Microcircuit Drawing 5962-01534
 - QML Q and V compliant part
- ❑ Compatible with ANSI/TIA/EIA-644 Standard

INTRODUCTION

The UT54LVDS217 Serializer converts 21 bits of CMOS/TTL data into three LVDS (Low Voltage Differential Signaling) data streams. A phase-locked transmit clock is transmitted in parallel with the data streams over a fourth LVDS link. Every cycle of the transmit clock 21 bits of input data are sampled and transmitted.

At a transmit clock frequency of 75MHz, 21 bits of TTL data are transmitted at a rate of 525 Mbps per LVDS data channel. Using a 75MHz clock, the data throughput is 1.575 Gbit/s (197 Mbytes/sec).

The UT54LVDS217 Serializer allows the use of wide, high speed TTL interfaces while reducing overall EMI and cable size.

All pins have Cold Spare buffers. These buffers will be high impedance when V_{DD} is tied to V_{SS}.

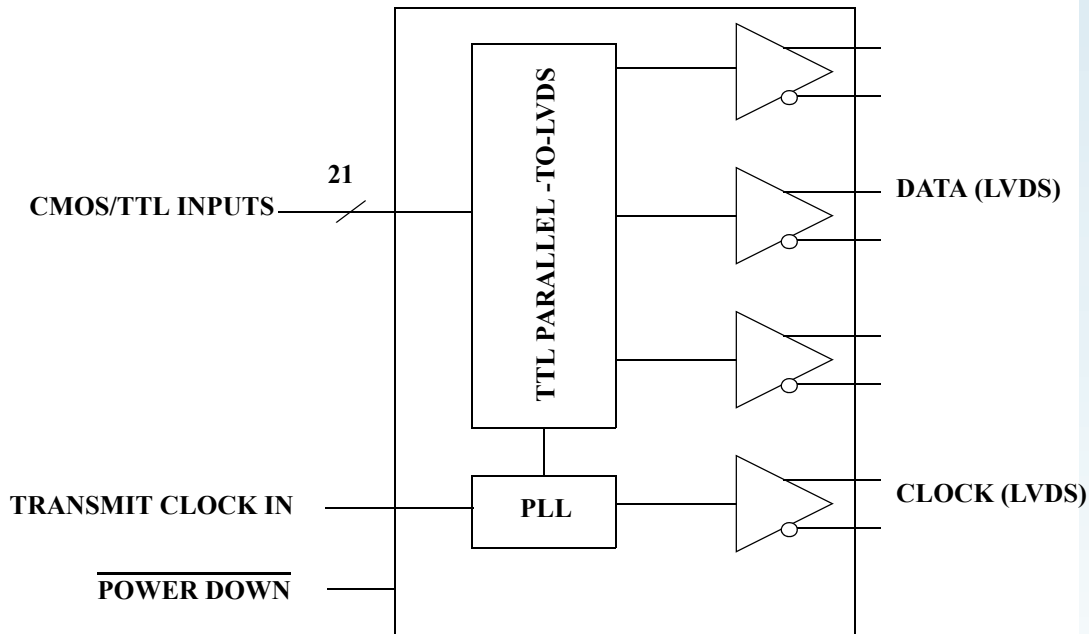

Figure 1. UT54LVDS217 Serializer Block Diagram

TxIN4	1	48	TxIN3
V _{DD}	2	47	TxIN2
TxIN5	3	46	GND
TxIN6	4	45	TxIN1
GND	5	44	TxIN0
TxIN7	6	43	N/C
TxIN8	7	42	LVDS GND
V _{DD}	8	41	TxOUT0-
TxIN9	9	40	TxOUT0+
TxIN10	10	39	TxOUT1-
GND	11	38	TxOUT1+
TxIN11	12	37	LVDS V _{DD}
TxIN12	13	36	LVDS GND
V _{DD}	14	35	TxOUT2-
TxIN13	15	34	TxOUT2+
TxIN14	16	33	TxCLK OUT-
GND	17	32	TxCLK OUT+
TxIN15	18	31	LVDS GND
TxIN16	19	30	PLL GND
TxIN17	20	29	PLL V _{DD}
V _{DD}	21	28	PLL GND
TxIN18	22	27	PWR DWN
TxIN19	23	26	TxCLK IN
GND	24	25	TxIN20

PIN DESCRIPTION

Pin Name	I/O	No.	Description
TxIN	I	21	TTL level input
TxOUT+	O	3	Positive LVDS differential data output
TxOUT-	O	3	Negative LVDS differential data output
TxCLK IN	I	1	TTL level clock input. The rising edge acts as data strobe. Pin name TxCLK IN
TxCLK OUT+	O	1	Positive LVDS differential clock output
TxCLK OUT-	O	1	Negative LVDS differential clock output
PWR DWN	I	1	TTL level input. Assertion (low input) TRI-STATES the clock and data outputs, ensuring low current at power down.
V _{DD}	I	4	Power supply pins for TTL inputs and logic
GND	I	5	Ground pins for TTL inputs and logic
PLL V _{DD}	I	1	Power supply pins for PLL
PLL GND	I	2	Ground pins for PPL
LVDS V _{DD}	I	1	Power supply pin for LVDS output
LVDS GND	I	3	Ground pins for LVDS outputs

Figure 2. UT54LVDS217 Pinout

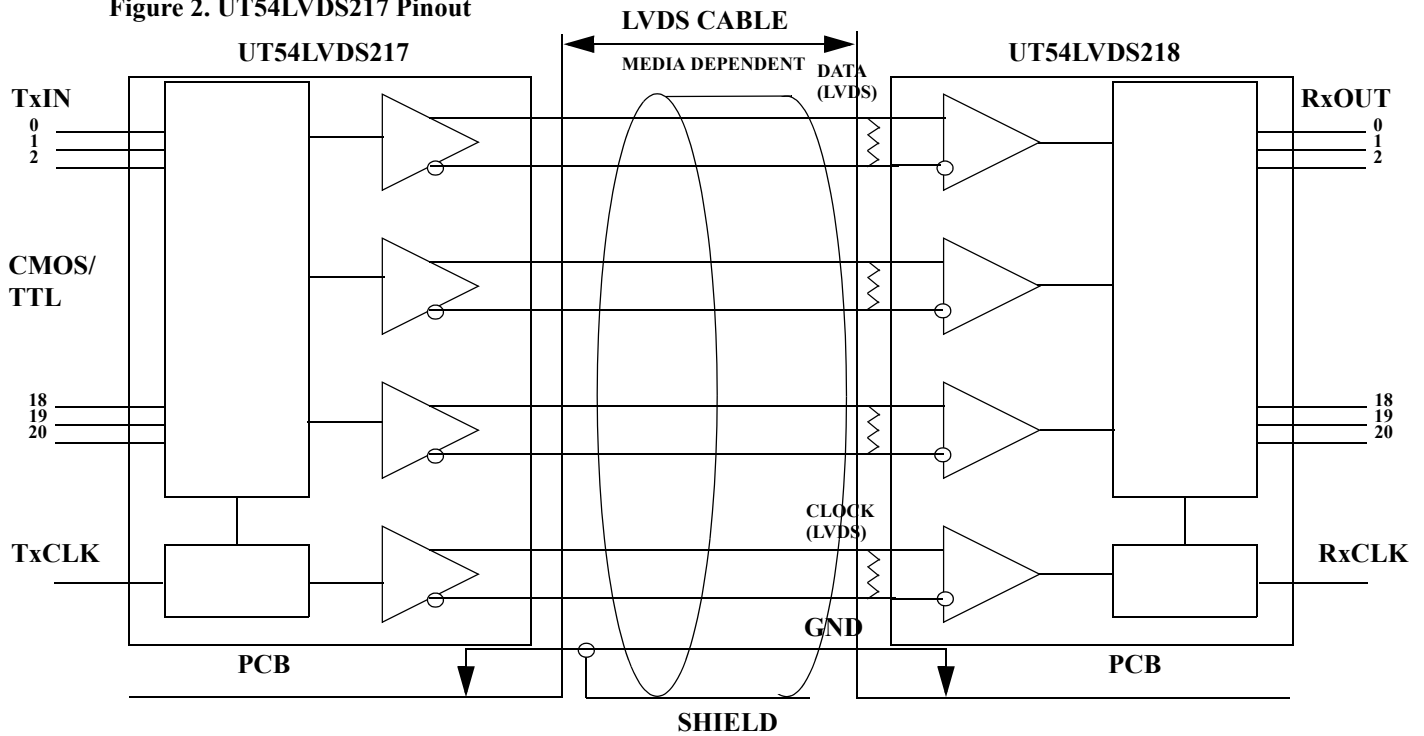

Figure 3. UT54LVDS217 Typical Application

OPERATIONAL ENVIRONMENT

PARAMETER	LIMIT	UNITS
Total Ionizing Dose (TID)	1.0E6	rad(Si)
Single Event Latchup (SEL)	>100	MeV-cm ² /mg
Neutron Fluence ¹	1.0E13	n/cm ²

Notes:

1. Guaranteed but not tested.

ABSOLUTE MAXIMUM RATINGS¹

(Referenced to V_{SS})

SYMBOL	PARAMETER	LIMITS
V _{DD}	DC supply voltage	-0.3 to 4.0V
V _{I/O}	Voltage on any pin ⁴	-0.3 to (V _{DD} + 0.3V)
T _{STG}	Storage temperature	-65 to +150°C
P _D	Maximum power dissipation	2 W
T _J	Maximum junction temperature ²	+150°C
Θ _{JC}	Thermal resistance, junction-to-case ³	10°C/W
I _I	DC input current	±10mA

Notes:

1. Stresses outside the listed absolute maximum ratings may cause permanent damage to the device. This is a stress rating only, and functional operation of the device at these or any other conditions beyond limits indicated in the operational sections of this specification is not recommended. Exposure to absolute maximum rating conditions for extended periods may affect device reliability and performance.
2. Maximum junction temperature may be increased to +175°C during burn-in and lifetest.
3. Test per MIL-STD-883, Method 1012.
4. For cold spare mode (V_{DD} = V_{SS}), V_{I/O} may be 0.3V to the maximum recommended operating V_{DD} + 0.3V.

RECOMMENDED OPERATING CONDITIONS

SYMBOL	PARAMETER	LIMITS
V _{DD} , P _{LL} V _{DD} , LVDS V _{DD}	Positive supply voltage	3.0 to 3.6V
T _C	Case temperature range	-55 to +125°C
V _{IN}	DC input voltage	0V to V _{DD}

DC ELECTRICAL CHARACTERISTICS*¹(V_{DD} = 3.3V-0.3V; -55°C < T_C < +125°C); Unless otherwise noted, T_c is per the temperature noted.

SYMBOL	PARAMETER	CONDITION	MIN	MAX	UNIT
CMOS/TTL DC SPECIFICATIONS					
V _{IH}	High-level input voltage		2.0	V _{DD}	V
V _{IL}	Low-level input voltage		GND	0.8	V
I _{IH}	High-level input current	V _{IN} = 3.6V; V _{DD} = 3.6V	-10	+10	μA
I _{IL}	Low-level input current	V _{IN} = 0V; V _{DD} = 3.6V	-10	+10	μA
V _{CL}	Input clamp voltage	I _{CL} = -18mA		-1.5	V
I _{CS}	Cold Spare Leakage current	V _{IN} = 3.6V; V _{DD} = V _{SS}	-20	+20	μA
LVDS OUTPUT DC SPECIFICATIONS (OUT+, OUT-)					
V _{OD} ⁵	Differential Output Voltage	R _L = 100Ω (See Figure 14)	250	400	mV
ΔV _{OD} ⁵	Change in V _{OD} between complimentary output states	R _L = 100Ω (See Figure 14)		35	mV
V _{OS} ⁵	Offset Voltage	R _L = 100Ω, (V _{OS} = $\frac{V_{OH} + V_{OL}}{2}$)	1.120	1.410	V
ΔV _{OS} ⁵	Change in V _{OS} between complimentary output states	R _L = 100Ω		35	mV
I _{OZ} ⁴	Output Three-State Current	PWR DWN = 0V V _{OUT} = 0V or V _{DD}	-10	+10	μA
I _{CSOUT}	Cold Spare Leakage Current	V _{IN} =3.6V, V _{DD} = V _{SS}	-20	+20	μA
I _{OS} ^{2,3}	Output Short Circuit Current	V _{OUT+} or V _{OUT-} = 0V		5mA	mA
Supply Current					
I _{CCL} ⁴	Transmitter supply current with loads	R _L = 100Ω all channels (figure 5) CL = 5pF, f = 50MHz		65.0	mA
I _{CCZ} ^{4,6}	Power down current	D _{IN} = V _{SS} PWR DWN = 0V, f = 0Hz		60.0	μA

Notes:

* For devices procured with a total ionizing dose tolerance guarantee, the post-irradiation performance is guaranteed at 25°C per MIL-STD-883 Method 1019, Condition A up to the maximum TID level procured.

1. Current into device pins is defined as positive. Current out of device pins is defined as negative. All voltages are referenced to ground.
2. Output short circuit current (I_{OS}) is specified as magnitude only, minus sign indicates direction only. Only one output should be shorted at a time, for a maximum duration of one second.
3. Guaranteed by characterization.
4. Devices are tested @ 3.6V only.
5. Clock outputs guaranteed by design.
6. Post 100Krad and 300Krad, I_{CCZ} = 200μA.

AC SWITCHING CHARACTERISTICS*¹

(V_{DD} = 3.0V to 3.6V; T_c = -55°C to +125°C); Unless otherwise noted, T_c is per the temperature ordered.

SYMBOL	PARAMETER	MIN	MAX	UNIT
LLHT ²	LVDS Low-to-High Transition Time (Figure 5)		1.5	ns
LHLT ²	LVDS High-to-Low Transition Time (Figure 5)		1.5	ns
TPPos0 ²	Transmitter Output Pulse Position for Bit 0 (Figure 13)	-0.18	0.270	ns
TPPos1 ²	Transmitter Output Pulse Position for Bit 1 (Figure 13) f=75MHz	1.72	2.17	ns
TPPos2 ²	Transmitter Output Pulse Position for Bit 2 (Figure 13) f=75MHz	3.63	4.08	ns
TPPos3 ²	Transmitter Output Pulse Position for Bit 3 (Figure 13) f=75MHz	5.53	5.98	ns
TPPos4 ²	Transmitter Output Pulse Position for Bit 4 (Figure 13) f=75MHz	7.44	7.89	ns
TPPos5 ²	Transmitter Output Pulse Position for Bit 5 (Figure 13) f=75MHz	9.34	9.79	ns
TPPos6 ²	Transmitter Output Pulse Position for Bit 6 (Figure 13) f=75MHz	11.25	11.70	ns
TCCS ³	Channel to Channel skew (Figure 7) f=75MHz		0.45	ns
TCIP	TxCLK IN Period (Figure 8)	13.3	66.7	ns
TCIH ⁴	TxCLK IN High Time (Figure 8)	0.35Tcip	0.65Tcip	ns
TCIL ⁴	TxCLK IN Low Time (Figure 8)	0.35Tcip	0.65Tcip	ns
TSTC ²	TxIN Setup to TxCLK IN (Figure 8)	15MHz 75MHz	1.0 0.5	ns
THTC ²	TxIN Hold to TxCLK IN (Figure 8)	15MHz 75MHz	0.7 0.5	ns
TCCD	TxCLK IN to TxCLK OUT Delay (Figure 9)	0.5	2.5	ns
TPLLS	Transmitter Phase Lock Loop Set (Figure 10)		10	ms
TPDD	Transmitter Powerdown Delay (Figure 12)		100	ns

Notes:

* For devices procured with a total ionizing dose tolerance guarantee, the post-irradiation performance is guaranteed at 25°C per MIL-STD-883 Method 1019, Condition A up to the maximum TID level procured.

1. Recommend transition time for TXCLK In is 1.0 to 6.0 ns (figure 6).

2. Guaranteed by characterization.

3. Channel to channel skew is defined as the difference between TPPOS max limit and TPPOS minimum limit.

4. Guaranteed by design.

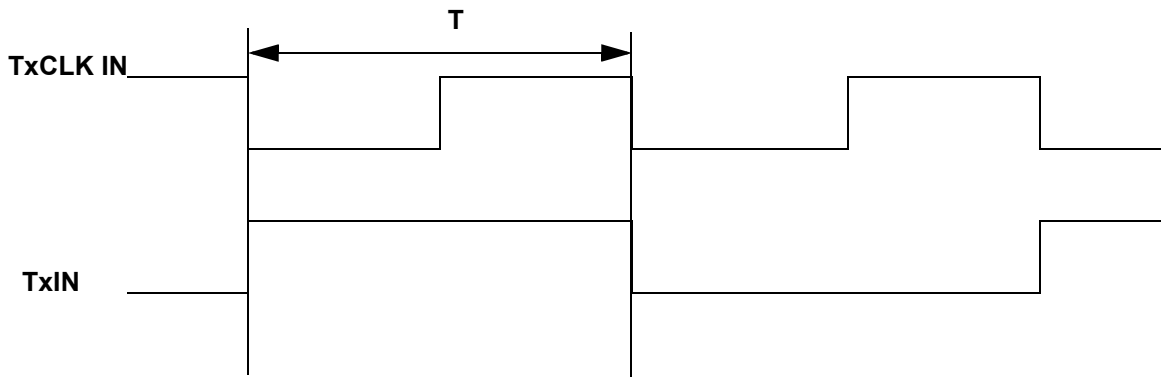

Figure 4. Test Pattern

AC TIMING DIAGRAMS

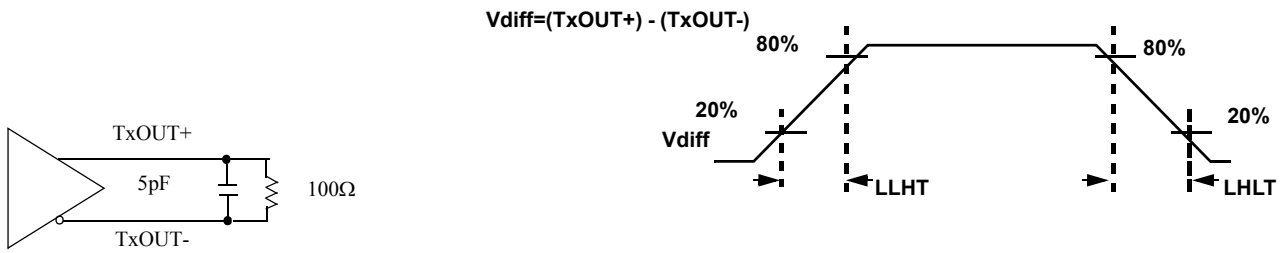

Figure 5. UT54LVDS217 Output Load and Transition Times

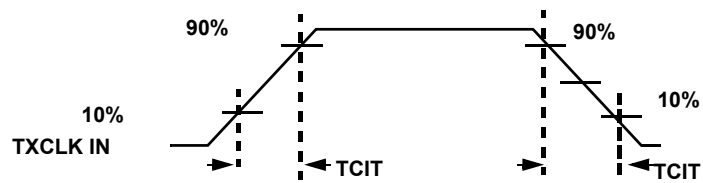
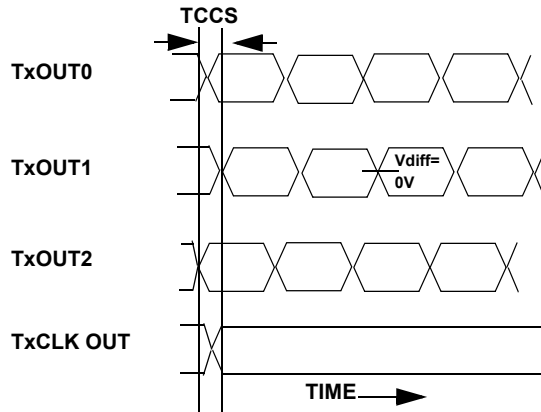

Figure 6. UT54LVDS217 Input Clock Transition Time



- Notes:
1. Measurements at $V_{DIFF} = 0V$
 2. TCCS measured between earliest and latest LVDS edges.
 3. TxCLK Differential Low-High Edge.

Figure 7. UT54LVDS217 Channel-to-Channel Skew

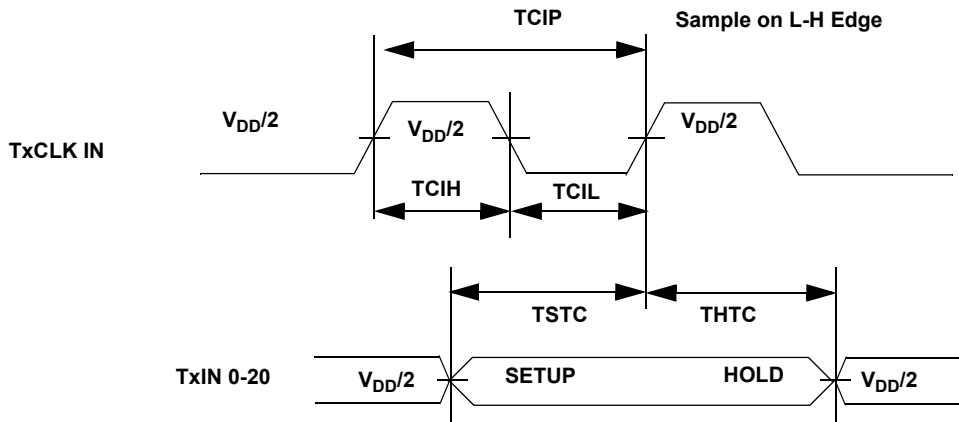

Figure 8. UT54LVDS217 Setup/Hold and High/Low Times

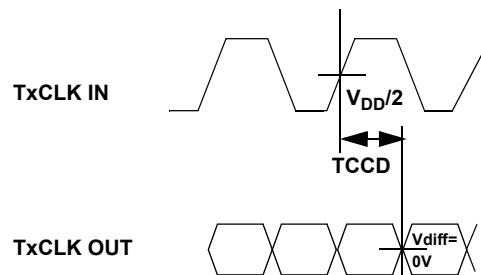

Figure 9. UT54LVDS217 Clock-to-Clock Out Delay

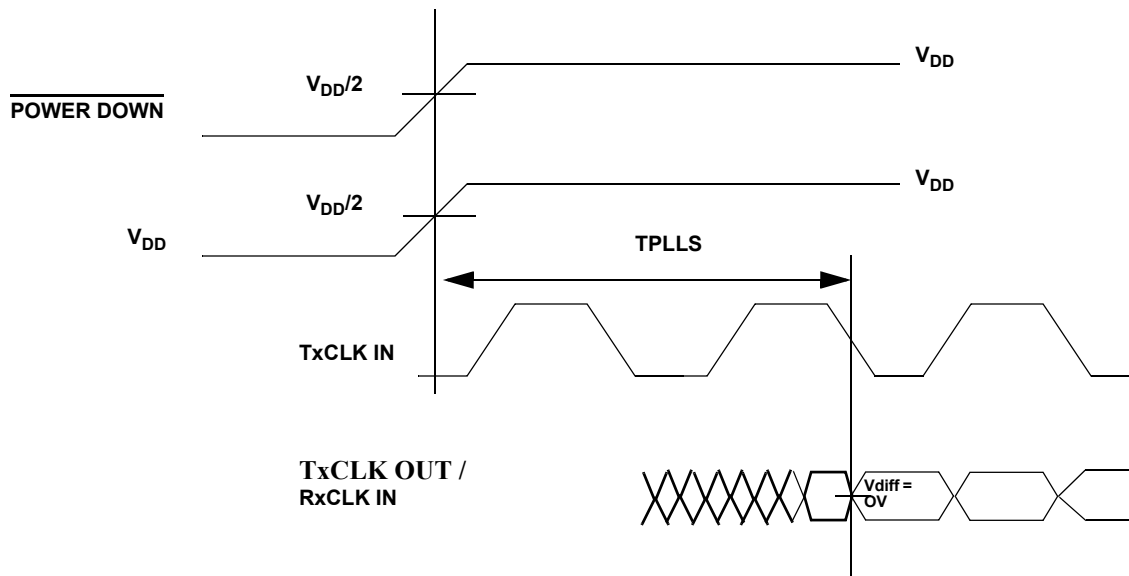

Figure 10. UT54LVDS217 Phase Lock Loop Set Time

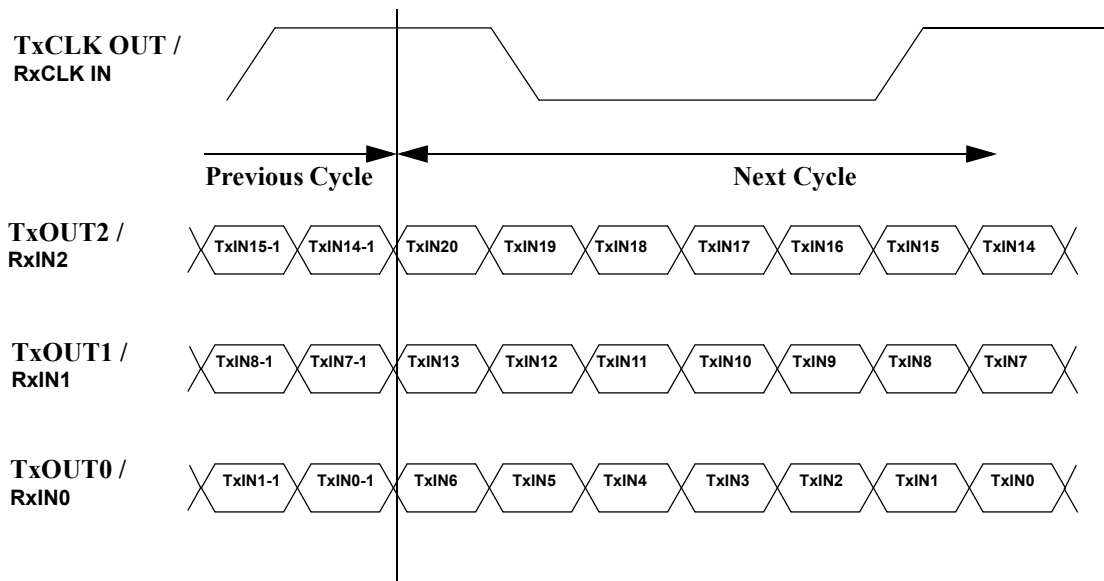

Figure 11. UT54LVDS217 Parallel TTL Data Inputs Mapped to LVDS Outputs

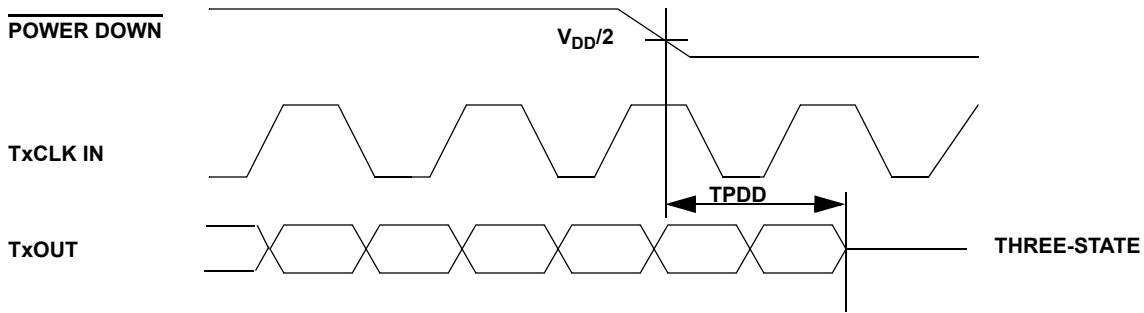

Figure 12. Transmitter Powerdown Delay

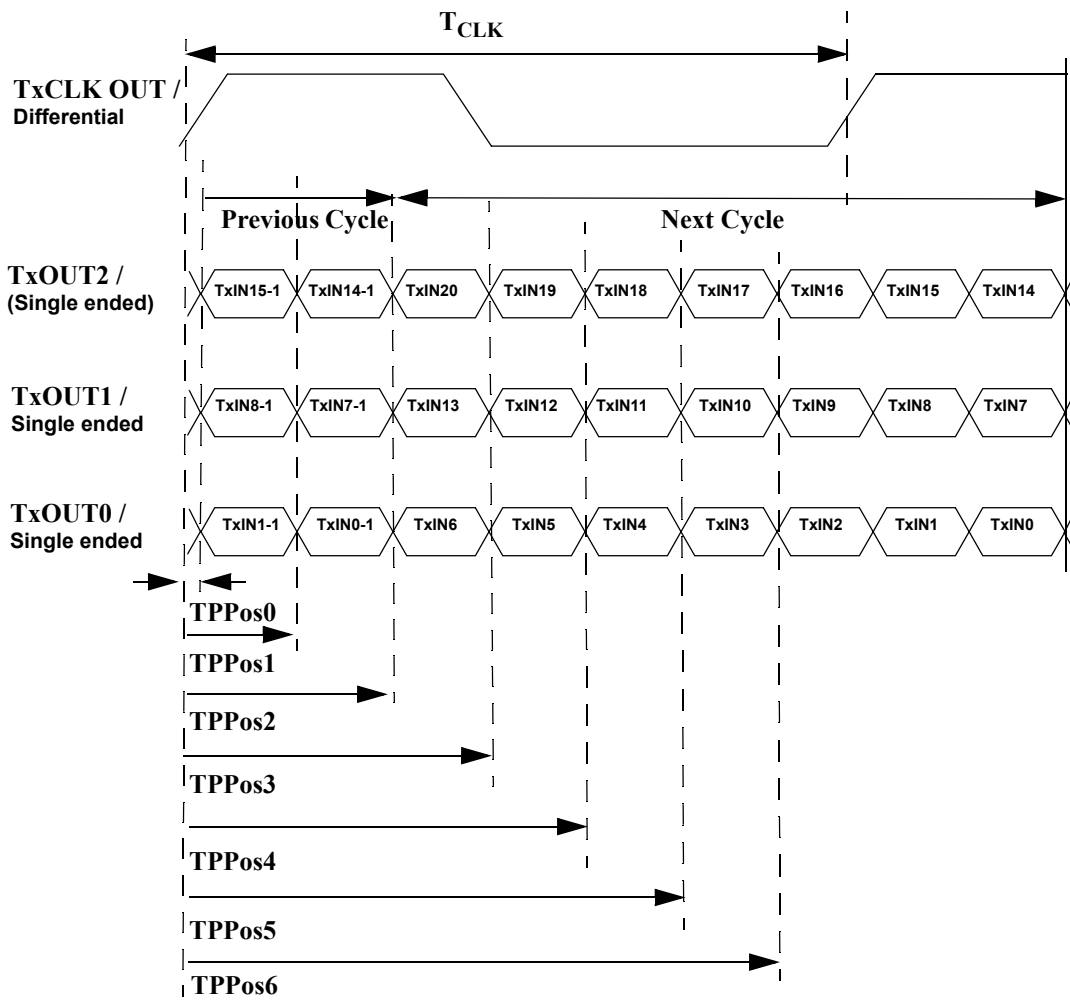

Figure 13. LVDS Output Pulse Position Measurement

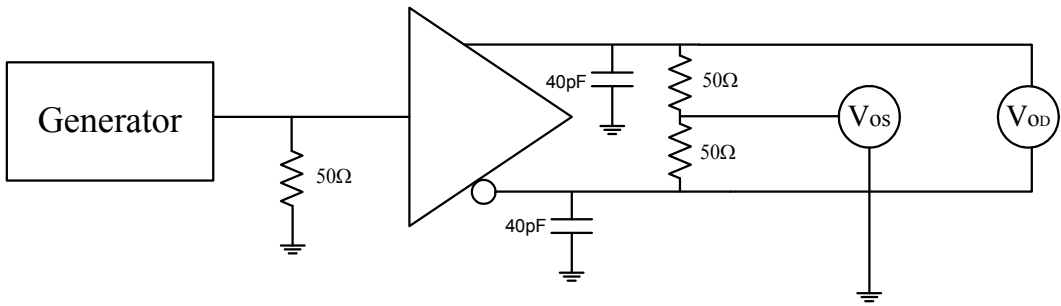
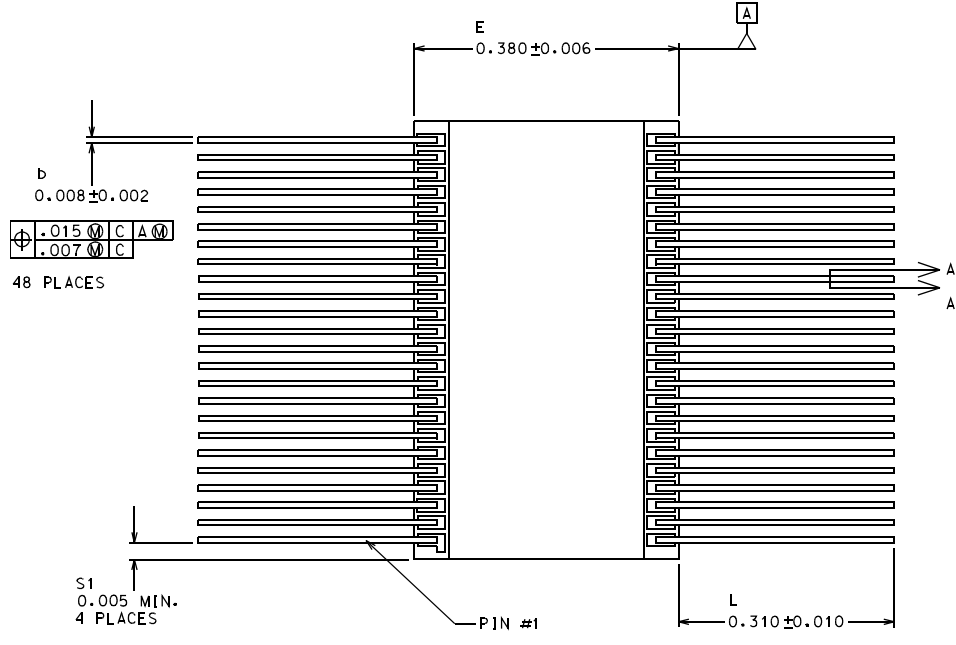
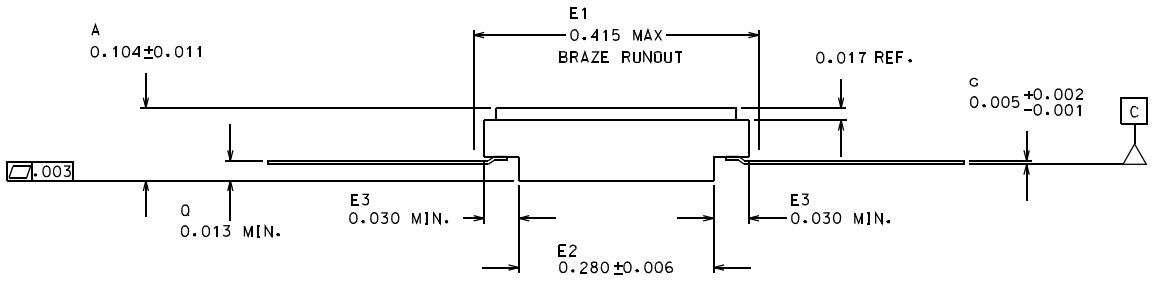
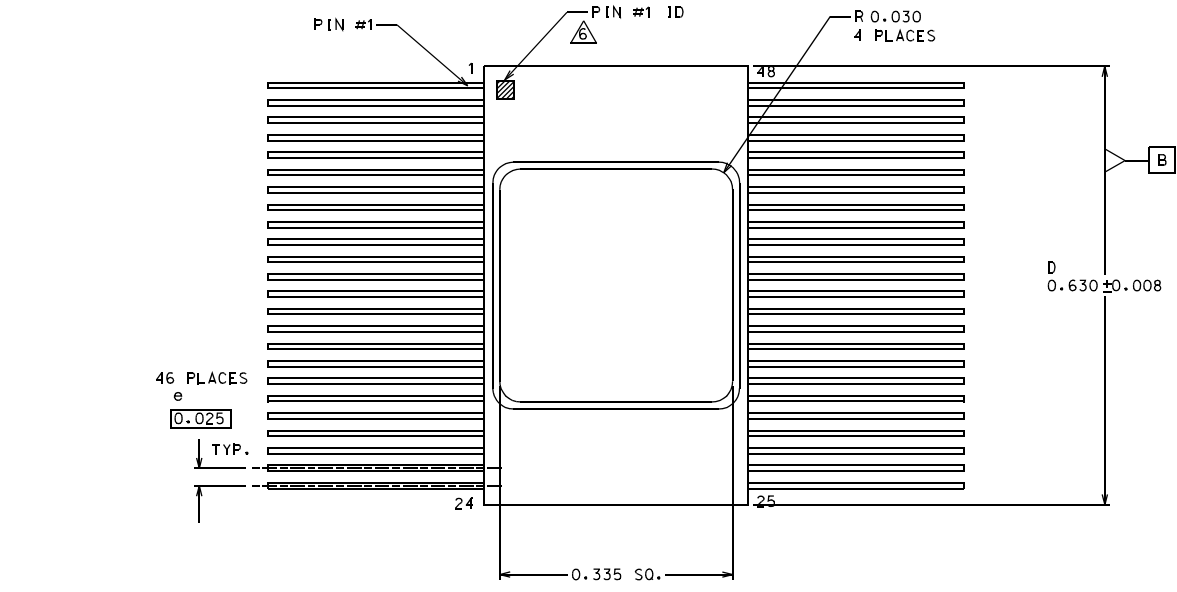

Figure 14. Driver V_{OD} and V_{OS} Test Circuit or Equivalent Circuit

50Ω



- Notes:**
1. All exposed metallized areas are gold plated over electrically plated nickel per MIL-PRF-38535.
 2. The lid is electrically connected to V_{SS} .
 3. Lead finishes are in accordance with MIL-PRF-38535.
 4. Dimension symbology is in accordance with MIL-PRF-38535.
 5. Lead position and coplanarity are not measured.
 6. ID mark symbol is vendor option: no alphanumerics.

Figure 15. 48-lead Ceramic

ORDERING INFORMATION

UT54LVDS217 Serializer:

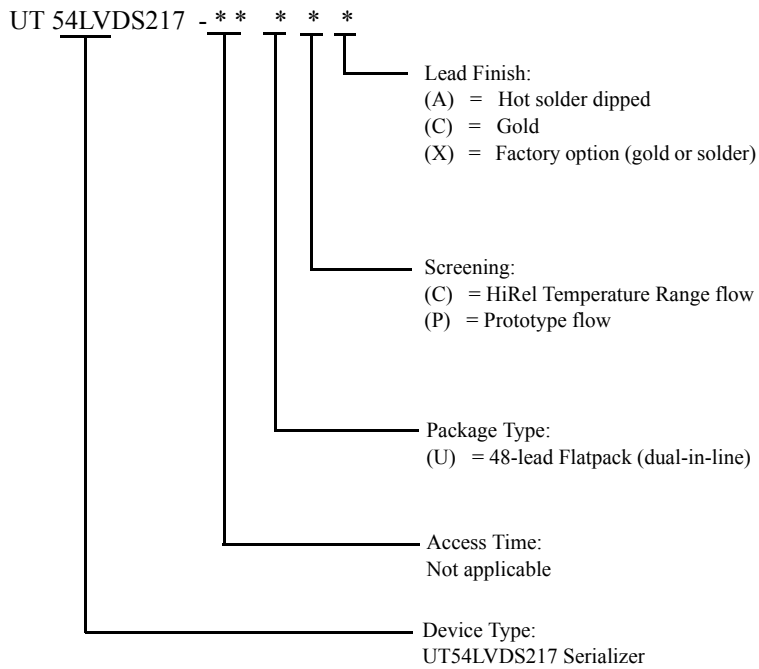

Notes:

1. Lead finish (A,C, or X) must be specified.
2. If an "X" is specified when ordering, then the part marking will match the lead finish and will be either "A" (solder) or "C" (gold).
3. Prototype flow per Aeroflex Manufacturing Flows Document. Tested at 25°C only. Lead finish is GOLD ONLY. Radiation neither tested nor guaranteed.
4. HiRel Temperature Range flow per Aeroflex Manufacturing Flows Document. Devices are tested at -55°C, room temp, and 125°C. Radiation neither tested nor guaranteed.

UT54LVDS217 Serializer: SMD

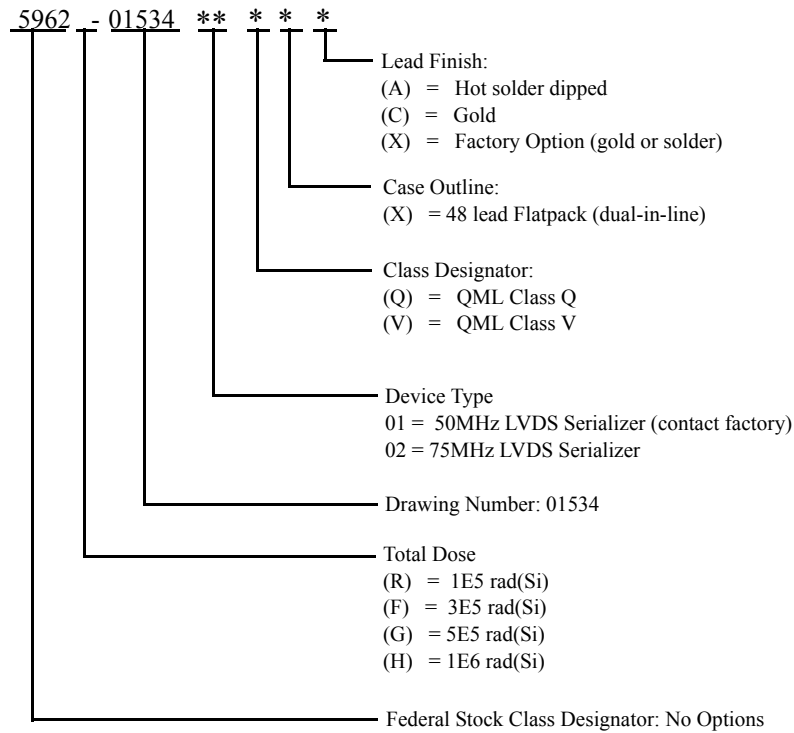

Notes:

1. Lead finish (A, C, or X) must be specified.
2. If an "X" is specified when ordering, part marking will match the lead finish and will be either "A" (solder) or "C" (gold).
3. Total dose radiation must be specified when ordering. QML Q and QML V not available without radiation hardening.

Aeroflex Colorado Springs - Datasheet Definition

Advanced Datasheet - Product In Development

Preliminary Datasheet - Shipping Prototype

Datasheet - Shipping QML & Reduced Hi-Rel

COLORADO

Toll Free: 800-645-8862
Fax: 719-594-8468

INTERNATIONAL

Tel: 805-778-9229
Fax: 805-778-1980

NORTHEAST

Tel: 603-888-3975
Fax: 603-888-4585

SE AND MID-ATLANTIC

Tel: 321-951-4164
Fax: 321-951-4254

WEST COAST

Tel: 949-362-2260
Fax: 949-362-2266

CENTRAL

Tel: 719-594-8017
Fax: 719-594-8468

www.aeroflex.com info-ams@aeroflex.com

Aeroflex UTMC Microelectronic Systems Inc. (Aeroflex) reserves the right to make changes to any products and services herein at any time without notice. Consult Aeroflex or an authorized sales representative to verify that the information in this data sheet is current before using this product. Aeroflex does not assume any responsibility or liability arising out of the application or use of any product or service described herein, except as expressly agreed to in writing by Aeroflex; nor does the purchase, lease, or use of a product or service from Aeroflex convey a license under any patent rights, copyrights, trademark rights, or any other of the intellectual rights of Aeroflex or of third parties.



Our passion for performance is defined by three attributes represented by these three icons: solution-minded, performance-driven and customer-focused