

UT8R1M39 40Megabit SRAM MCM

UT8R2M39 80Megabit SRAM MCM

UT8R4M39 160Megabit SRAM MCM

Data Sheet

January 2013

www.aeroflex.com/memories



FEATURES

- ❑ 20ns Read, 10ns Write maximum access times available
- ❑ Functionally compatible with traditional 1M, 2M, or 4M x 39 SRAM devices
- ❑ CMOS compatible input and output levels, three-state bidirectional data bus
 - I/O Voltages 2.3V to 3.6V, 1.7V to 2.0V core
- ❑ Available densities:
 - UT8R1M39: 40, 894, 464 bits
 - UT8R2M39: 81, 788, 928 bits
 - UT8R4M39: 163, 577, 856 bits
- ❑ Operational Environment:
 - Total-dose: 100 krad(Si)
 - SEL Immune: $\leq 110 \text{ MeV}\cdot\text{cm}^2/\text{mg}$
 - SEU error rate = 7.3×10^{-7} errors/bit-day assuming geosynchronous orbit, Adam's 90% worst environment.
- ❑ Packaging options:
 - 132-lead side-brazed dual cavity ceramic quad flatpack
- ❑ Standard Microelectronics Drawing:
 - UT8R1M39: 5962-10205
 - QML Q, Q+ and V compliant part
 - UT8R2M39: 5962-10206
 - QML Q, Q+ compliant part
 - UT8R4M39: 5962-10207
 - QML Q and Q+ compliant part

INTRODUCTION

The UT8R1M39, UT8R2M39, and UT8R4M39 are high performance CMOS static RAM multichip modules (MCMs) organized as two, four or eight individual 524,288 words x 39 bits dice respectively. Easy memory expansion is provided by active LOW chip enables ($\overline{E_n}$), an active LOW output enable (\overline{G}), and three-state drivers. This device has a power-down feature that reduces power consumption by more than 90% when deselected.

Writing to the device is accomplished by driving one of the chip enable ($\overline{E_n}$) inputs LOW and the write enable (\overline{W}) input LOW. Data on the 39 I/O pins (DQ0 through DQ38) is then written into the location specified on the address pins (A0 through A18). Reading from the device is accomplished by driving one of the chip enables ($\overline{E_n}$) and output enable (\overline{G}) LOW while driving write enable (\overline{W}) HIGH. Under these conditions, the contents of the memory location specified by the address pins will appear on the I/O pins. **Note:** Only one $\overline{E_n}$ pin may be active at any time.

The 39 input/output pins (DQ0 through DQ38) are placed in a high impedance state when the device is deselected ($\overline{E_n}$ HIGH), the outputs are disabled (\overline{G} HIGH), or during a write operation ($\overline{E_n}$ LOW, \overline{W} LOW).

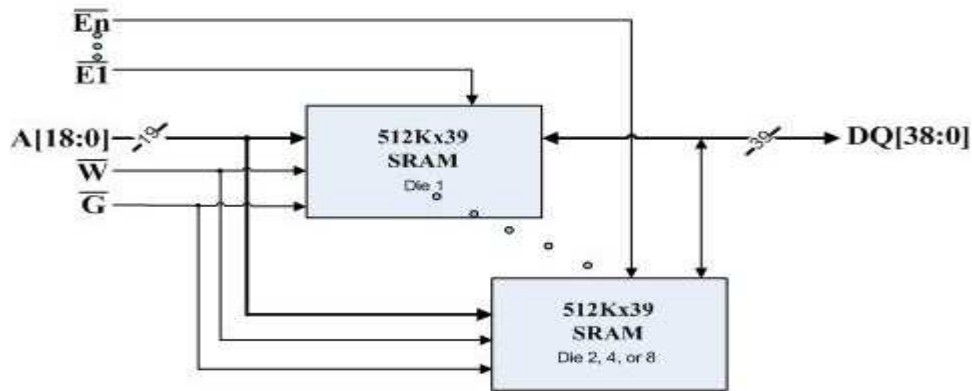
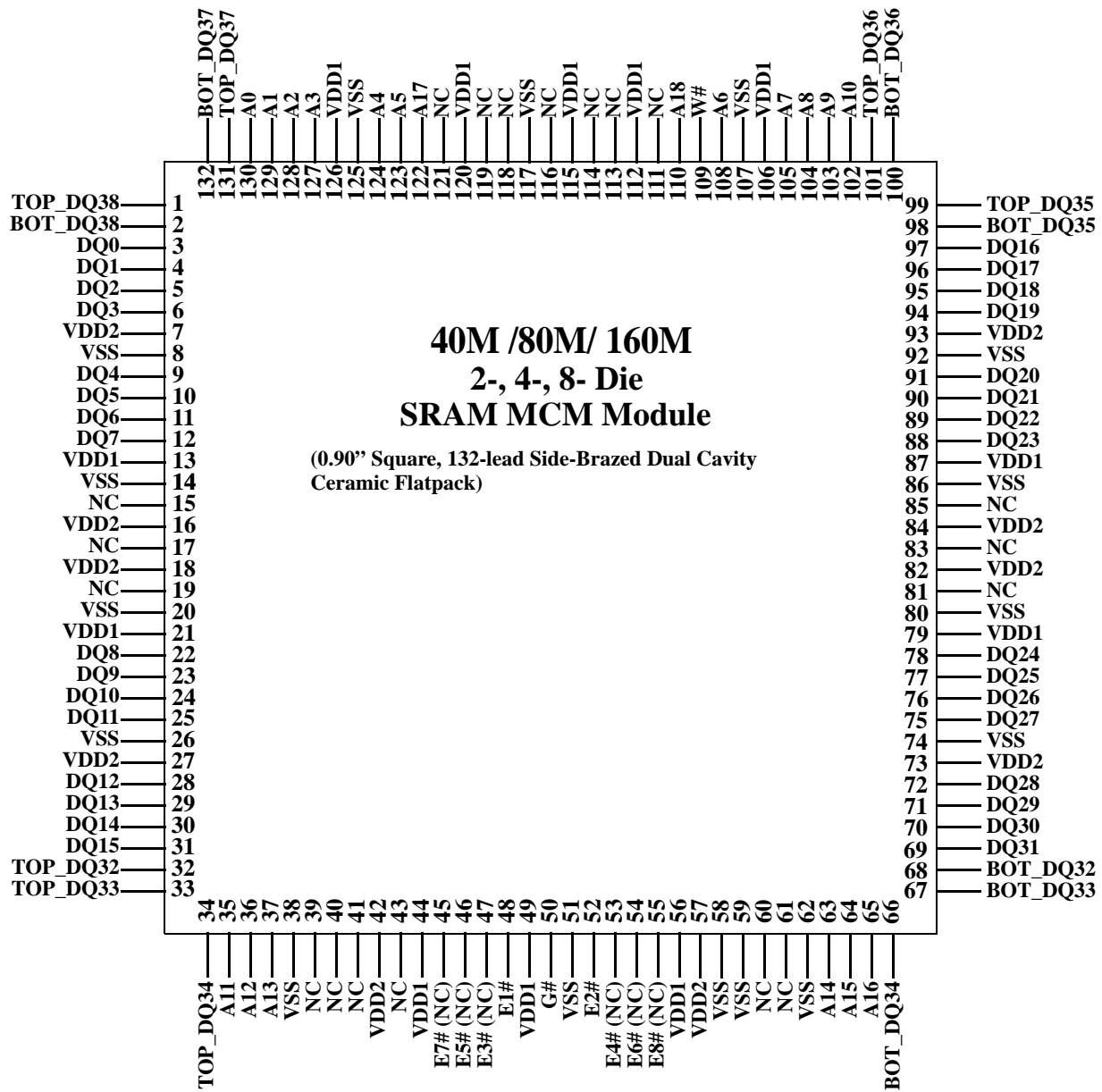

Figure 1. Block Diagram



Notes:

1. NC= Pins are not connected on die.
2. (NC) = Depending on product version, the pin may be either an enable signal as named or NC.
3. Each TOP and BOT signal for DQ38 through DQ32 must be externally connected by user.

Figure 2. Pin Diagram

Table 1. Device Option: Signal and Pin Description

Package Pin Number	UT8R1M39 Signal Name	UT8R2M39 Signal Name	UT8R4M39 Signal Name	Device Pin Description
1	TOP_DQ38	TOP_DQ38	TOP_DQ38	Data I/O ¹
2	BOT_DQ38	BOT_DQ38	BOT_DQ38	Data I/O ¹
3	DQ0	DQ0	DQ0	Data I/O
4	DQ1	DQ1	DQ1	Data I/O
5	DQ2	DQ2	DQ2	Data I/O
6	DQ3	DQ3	DQ3	Data I/O
7	VDD2	VDD2	VDD2	PWR
8	VSS	VSS	VSS	PWR
9	DQ4	DQ4	DQ4	Data I/O
10	DQ5	DQ5	DQ5	Data I/O
11	DQ6	DQ6	DQ6	Data I/O
12	DQ7	DQ7	DQ7	Data I/O
13	VDD1	VDD1	VDD1	PWR
14	VSS	VSS	VSS	PWR
15	NC	NC	NC	NC
16	VDD2	VDD2	VDD2	PWR
17	NC	NC	NC	NC
18	VDD2	VDD2	VDD2	PWR
19	NC	NC	NC	NC
20	VSS	VSS	VSS	PWR
21	VDD1	VDD1	VDD1	PWR
22	DQ8	DQ8	DQ8	Data I/O
23	DQ9	DQ9	DQ9	Data I/O
24	DQ10	DQ10	DQ10	Data I/O
25	DQ11	DQ11	DQ11	Data I/O
26	VSS	VSS	VSS	PWR
27	VDD2	VDD2	VDD2	PWR
28	DQ12	DQ12	DQ12	Data I/O
29	DQ13	DQ13	DQ13	Data I/O

Table 1. Device Option: Signal and Pin Description

Package Pin Number	UT8R1M39 Signal Name	UT8R2M39 Signal Name	UT8R4M39 Signal Name	Device Pin Description
30	DQ14	DQ14	DQ14	Data I/O
31	DQ15	DQ15	DQ15	Data I/O
32	TOP_DQ32	TOP_DQ32	TOP_DQ32	Data I/O ¹
33	TOP_DQ33	TOP_DQ33	TOP_DQ33	Data I/O ¹
34	TOP_DQ34	TOP_DQ34	TOP_DQ34	Data I/O ¹
35	A11	A11	A11	ADDRESS INPUT
36	A12	A12	A12	ADDRESS INPUT
37	A13	A13	A13	ADDRESS INPUT
38	VSS	VSS	VSS	PWR
39	NC	NC	NC	NC
40	NC	NC	NC	NC
41	NC	NC	NC	NC
42	VDD2	VDD2	VDD2	PWR
43	NC	NC	Nc	NC
44	VDD1	VDD1	VDD1	PWR
45	NC	NC	E7#	CONTROL INPUT ²
46	NC	NC	E5#	CONTROL INPUT ²
47	NC	E3#	E3#	CONTROL INPUT ²
48	E1#	E1#	E1#	CONTROL INPUT
49	VDD1	VDD1	VDD1	PWR
50	G#	G#	G#	CONTROL INPUT
51	VSS	VSS	VSS	PWR
52	E2#	E2#	E2#	CONTROL INPUT
53	NC	E4#	E4#	CONTROL INPUT ²
54	NC	NC	E6#	CONTROL INPUT ²
55	NC	NC	E8#	CONTROL INPUT ²
56	VDD1	VDD1	VDD1	PWR
57	VDD2	VDD2	VDD2	PWR
58	VSS	VSS	VSS	PWR
59	VSS	VSS	VSS	PWR
60	NC	NC	NC	NC

Table 1. Device Option: Signal and Pin Description

Package Pin Number	UT8R1M39 Signal Name	UT8R2M39 Signal Name	UT8R4M39 Signal Name	Device Pin Description
61	NC	NC	NC	NC
62	VSS	VSS	VSS	PWR
63	A14	A14	A14	ADDRESS INPUT
64	A15	A15	A15	ADDRESS INPUT
65	A16	A16	A16	ADDRESS INPUT
66	BOT_DQ34	BOT_DQ34	BOT_DQ34	Data I/O ¹
67	BOT_DQ33	BOT_DQ33	BOT_DQ33	Data I/O ¹
68	BOT_DQ32	BOT_DQ32	BOT_DQ32	Data I/O ¹
69	DQ31	DQ31	DQ31	Data I/O
70	DQ30	DQ30	DQ30	Data I/O
71	DQ29	DQ29	DQ29	Data I/O
72	DQ28	DQ28	DQ28	Data I/O
73	VDD2	VDD2	VDD2	PWR ¹
74	VSS	VSS	VSS	PWR
75	DQ27	DQ27	DQ27	Data I/O
76	DQ26	DQ26	DQ26	Data I/O
77	DQ25	DQ25	DQ25	Data I/O
78	DQ24	DQ24	DQ24	Data I/O
79	VDD1	VDD1	VDD1	PWR
80	VSS	VSS	VSS	PWR
81	NC	NC	NC	NC
82	VDD2	VDD2	VDD2	PWR
83	NC	NC	NC	NC
84	VDD2	VDD2	VDD2	PWR
85	NC	NC	NC	NC
86	VSS	VSS	VSS	PWR
87	VDD1	VDD1	VDD1	PWR
88	DQ23	DQ23	DQ23	Data I/O
89	DQ22	DQ22	DQ22	Data I/O
90	DQ21	DQ21	DQ21	Data I/O

Table 1. Device Option: Signal and Pin Description

Package Pin Number	UT8R1M39 Signal Name	UT8R2M39 Signal Name	UT8R4M39 Signal Name	Device Pin Description
91	DQ20	DQ20	DQ20	Data I/O
92	VSS	VSS	VSS	PWR
93	VDD2	VDD2	VDD2	PWR
94	DQ19	DQ19	DQ19	Data I/O
95	DQ18	DQ18	DQ18	Data I/O
96	DQ17	DQ17	DQ17	Data I/O
97	DQ16	DQ16	DQ16	Data I/O
98	BOT_DQ35	BOT_DQ35	BOT_DQ35	Data I/O ¹
99	TOP_DQ35	TOP_DQ35	TOP_DQ35	Data I/O ¹
100	BOT_DQ36	BOT_DQ36	BOT_DQ36	Data I/O ¹
101	TOP_DQ36	TOP_DQ36	TOP_DQ36	Data I/O ¹
102	A10	A10	A10	ADDRESS INPUT
103	A9	A9	A9	ADDRESS INPUT
104	A8	A8	A8	ADDRESS INPUT
105	A7	A7	A7	ADDRESS INPUT
106	VDD1	VDD1	VDD1	PWR
107	VSS	VSS	VSS	PWR
108	A6	A6	A6	ADDRESS INPUT
109	W#	W#	W#	CONTROL INPUT
110	A18	A18	A18	ADDRESS INPUT
111	NC	NC	NC	NC
112	VDD1	VDD1	VDD1	PWR
113	NC	NC	NC	NC
114	NC	NC	NC	NC
115	VDD1	VDD1	VDD1	PWR
116	NC	NC	NC	NC
117	VSS	VSS	VSS	PWR
118	NC	NC	NC	NC
119	NC	NC	NC	NC
120	VDD1	VDD1	VDD1	PWR
121	NC	NC	NC	NC

Table 1. Device Option: Signal and Pin Description

Package Pin Number	UT8R1M39 Signal Name	UT8R2M39 Signal Name	UT8R4M39 Signal Name	Device Pin Description
122	A17	A17	A17	ADDRESS INPUT
123	A5	A5	A5	ADDRESS INPUT
124	A4	A4	A4	ADDRESS INPUT
125	VSS	VSS	VSS	PWR
126	VDD1	VDD1	VDD1	PWR
127	A3	A3	A3	ADDRESS INPUT
128	A2	A2	A2	ADDRESS INPUT
129	A1	A1	A1	ADDRESS INPUT
130	A0	A0	A0	ADDRESS INPUT
131	TOP_DQ37	TOP_DQ37	TOP_DQ37	Data I/O ¹
132	BOT_DQ37	BOT_DQ37	BOT_DQ37	Data I/O ¹

Notes:

NC pins are not connected on the die.

1. Each TOP and BOT signal pin for DQ38 through DQ32 must be externally connected together by user.
2. Control input when declared as En#, otherwise pin is NC.

DEVICE OPERATION

The SRAMs have control inputs called Chip Enable ($\overline{\text{En}}$), Write Enable ($\overline{\text{W}}$), and Output Enable ($\overline{\text{G}}$); 19 address inputs, A(18:0); and 39 bidirectional data lines, DQ(38:0). The $\overline{\text{En}}$ (chip enable) controls selection between active and standby modes. Asserting $\overline{\text{En}}$ enables the device, causes I_{DD} to rise to its active value, and decodes the 19 address inputs. Only one chip enable may be active at anytime. $\overline{\text{W}}$ controls read and write operations. During a read cycle, $\overline{\text{G}}$ must be asserted to enable the outputs.

Table 2. SRAM Device Control Operation Truth Table

$\overline{\text{G}}$	$\overline{\text{W}}$	$\overline{\text{En}}$	I/O Mode	Mode
X	X	H	DQ(38:0) 3-State	Standby
L	H	L	DQ(38:0) Data Out	Word Read
H	H	L	DQ(38:0) All 3-State	Word Read ²
X	L	L	DQ(38:0) Data In	Word Write

Notes:

1. "X" is defined as a "don't care" condition.
2. Device active; outputs disabled.

READ CYCLE

A combination of $\overline{\text{W}}$ greater than V_{IH} (min) with a single $\overline{\text{En}}$ and $\overline{\text{G}}$ less than V_{IL} (max) defines a read cycle. Read access time is measured from the latter of device enable, output enable, or valid address to valid data output.

SRAM Read Cycle 1, the Address Access in Figure 3a, is initiated by a change in address inputs after a single $\overline{\text{En}}$ is asserted, $\overline{\text{G}}$ is asserted, $\overline{\text{W}}$ is deasserted and are all stable. Valid data appears on data outputs DQ(38:0) after the specified t_{AVQV} is satisfied. Outputs remain active throughout the entire cycle. As long as device enable and output enable are active, the

minimum time between valid address changes is specified by the read cycle time (t_{AVAV1}).

SRAM Read Cycle 2, the Chip Enable-controlled Access in Figure 3b, is initiated by a single $\overline{\text{En}}$ going active while $\overline{\text{G}}$ remains asserted, $\overline{\text{W}}$ remains deasserted, and the addresses remain stable for the entire cycle. After the specified t_{ETQV} is satisfied, the 39-bit word addressed by A(18:0) is accessed and appears at the data outputs DQ(38:0).

SRAM Read Cycle 3, the Output Enable-controlled Access in Figure 3c, is initiated by $\overline{\text{G}}$ going active while a single $\overline{\text{En}}$ is asserted, $\overline{\text{W}}$ is deasserted, and the addresses are stable. Read access time is t_{GLQV} unless t_{AVQV} or t_{ETQV} (reference Figure 3b) have not been satisfied.

WRITE CYCLE

A combination of $\overline{\text{W}}$ and a single $\overline{\text{En}}$ less than V_{IL} (max) defines a write cycle. The state of $\overline{\text{G}}$ is a "don't care" for a write cycle. The outputs are placed in the high-impedance state when either $\overline{\text{G}}$ is greater than V_{IH} (min), or when $\overline{\text{W}}$ is less than V_{IL} (max).

Write Cycle 1, the Write Enable-controlled Access in Figure 4a, is defined by a write terminated by $\overline{\text{W}}$ going high, with a single $\overline{\text{En}}$ still active. The write pulse width is defined by t_{WLWH} when the write is initiated by $\overline{\text{W}}$, and by t_{ETWH} when the write is initiated by $\overline{\text{En}}$. To avoid bus contention t_{WLQZ} must be satisfied before data is applied to the 39 bidirectional pins DQ(38:0) unless the outputs have been previously placed in high impedance state by deasserting $\overline{\text{G}}$.

Write Cycle 2, the Chip Enable-controlled Access in Figure 4b, is defined by a write terminated by a single $\overline{\text{En}}$. The write pulse width is defined by t_{WLEF} when the write is initiated by $\overline{\text{W}}$, and by t_{ETEF} when the write is initiated by $\overline{\text{En}}$ going active. For the $\overline{\text{W}}$ initiated write, unless the outputs have been previously placed in the high-impedance state by $\overline{\text{G}}$, the user must wait t_{WLQZ} before applying data to the 39 bidirectional pins DQ(38:0) to avoid bus contention.

Table 3. Operational Environment¹

Total Dose	100K	rads(Si)
Heavy Ion Error Rate ²	7.3×10^{-7}	Errors/Bit-Day

Notes:

1. The SRAM is immune to latchup to particles $\leq 110 \text{MeV-cm}^2/\text{mg}$.
2. 90% worst case particle environment, Geosynchronous orbit, 100 mils of Aluminum.

SUPPLY SEQUENCING

No supply voltage sequencing is required between V_{DD1} and V_{DD2} .

POWER-UP REQUIREMENTS

During power-up of the SRAM devices, the power supply voltages will traverse through voltage ranges where the device is not guaranteed to operate before reaching final levels. Since some circuits on the device may operate at lower voltage levels than others, the device may power-up in an unknown state. To eliminate this with most power-up situations, the device employs an on-chip power-on-reset (POR) circuit. The POR, however, requires time to complete the operation. Therefore, it is recommended that all device activity be delayed by a minimum of 100ms, after both V_{DD1} and V_{DD2} supplies have reached their respective minimum operating voltages.

EXTERNAL CONNECTION REQUIREMENTS

Bidirectional data lines DQ38-DQ32 have both a TOP and BOT pinout. TOP and BOT for each data line must be externally connected together by user.

ABSOLUTE MAXIMUM RATINGS¹

(Referenced to V_{SS})

SYMBOL	PARAMETER	LIMITS
V_{DD1}	DC supply voltage (Core)	-0.3 to 2.1V
V_{DD2}	DC supply voltage (I/O)	-0.3 to 3.8V
$V_{I/O}$	Voltage on any pin	-0.3 to 3.8V
T_{STG}	Storage temperature	-65 to +150°C
P_D^2 UT8R1M39 UT8R2M39 UT8R4M39	Maximum package power dissipation permitted @ $T_c = +105^\circ\text{C}$	3.3W 2W 1.3W
T_J	Maximum junction temperature	+150°C
Θ_{JC}^3 UT8R1M39 UT8R2M39 UT8R4M39	Thermal resistance, junction-to-case ²	6°C/W 10°C/W 15°C/W
I_I	DC input current	± 10 mA

Notes:

- Stresses outside the listed absolute maximum ratings may cause permanent damage to the device. This is a stress rating only, and functional operation of the device at these or any other conditions beyond limits indicated in the operational sections of this specification is not recommended. Exposure to absolute maximum rating conditions for extended periods may affect device reliability and performance.
- Per MIL-STD-883, Method 1012, Section 3.4.1, $P_D = \frac{(125^\circ\text{C} - 105^\circ\text{C})}{\Theta_{JC}}$
- Θ_{JC} varies with density due to stacked die configuration.

RECOMMENDED OPERATING CONDITIONS

SYMBOL	PARAMETER	LIMITS
V_{DD1}	DC supply voltage (Core)	1.7 to 2.0V
V_{DD2}	DC supply voltage (I/O)	2.3 to 3.6V
T_C	Case temperature range	-55°C to +105°C
V_{IN}	DC input voltage	0V to V_{DD2}

DC ELECTRICAL CHARACTERISTICS (Pre and Post-Radiation)*

($V_{DD1} = 1.7V$ to $2.0V$, $V_{DD2} = 2.3V$ to $3.6V$; Unless otherwise noted, T_c is per the temperature range ordered)

SYMBOL	PARAMETER	CONDITION	MIN	MAX	UNIT	
V_{IH}	High-level input voltage		2.2		V	
V_{IL}	Low-level input voltage			0.8	V	
V_{OL1}	Low-level output voltage	$I_{OL} = 8mA, 3.0V \leq V_{DD2} \leq 3.6V$		0.4	V	
V_{OL2}	Low-level output voltage	$I_{OL} = 6mA, 2.3V \leq V_{DD2} \leq 2.7V$		$0.2 * V_{DD2}$		
V_{OH1}	High-level output voltage	$I_{OH} = -4mA, 3.0V \leq V_{DD2} \leq 3.6V$	$0.8 * V_{DD2}$		V	
V_{OH2}	High-level output voltage	$I_{OL} = -2mA, 2.3V \leq V_{DD2} \leq 2.7V$	$0.8 * V_{DD2}$			
I_{IN}	Input leakage current	$V_{IN} = V_{DD2}$ and V_{SS}	-2	2	μA	
I_{OZ}	Three-state output leakage current	$V_O = V_{DD2}$ and V_{SS} $V_{DD2} = V_{DD2}(\max), \bar{G} = V_{DD2}(\max)$	-2	2	μA	
$I_{OS}^{2,3}$	Short-circuit output current	$V_{DD2} = V_{DD2}(\max), V_O = V_{DD2}$ $V_{DD2} = V_{DD2}(\max), V_O = V_{SS}$	-100	+100	mA	
$I_{DD1}(OP_1)^5$	V_{DD1} Supply current read operation @ 1MHz	Inputs: $V_{IL} = V_{SS} + 0.2V$, $V_{IH} = V_{DD2} - 0.2V, I_{OUT} = 0$ $V_{DD2} = V_{DD2}(\max)$	$V_{DD1} = 2.0V$		14	mA
			$V_{DD1} = 1.9V$		10	mA
$I_{DD1}(OP_2)^{5,6}$	V_{DD1} Supply current read operation @ f_{max}	Inputs: $V_{IL} = V_{SS} + 0.2V$, $V_{IH} = V_{DD2} - 0.2V, I_{OUT} = 0$ $V_{DD2} = V_{DD2}(\max)$	$V_{DD1} = 2.0V$		230	mA
			$V_{DD1} = 1.9V$ UT8R4M39		215	mA
			$V_{DD1} = 2.0V$ $V_{DD1} = 1.9V$ UT8R1M39 UT8R2M39		225 210	mA mA
$I_{DD2}(OP_1)^5$	V_{DD2} Supply current read operation @ 1MHz	Inputs : $V_{IL} = V_{SS} + 0.2V$, $V_{IH} = V_{DD2} - 0.2V, I_{OUT} = 0$ $V_{DD1} = V_{DD1}(\max), V_{DD2} = V_{DD2}(\max)$		2	mA	
$I_{DD2}(OP_2)^{5,6}$	V_{DD2} Supply current read operation @ f_{max}	Inputs : $V_{IL} = V_{SS} + 0.2V$, $V_{IH} = V_{DD2} - 0.2V, I_{OUT} = 0$ $V_{DD1} = V_{DD1}(\max), V_{DD2} = V_{DD2}(\max)$		5	mA	

SYMBOL	PARAMETER	CONDITION	MIN	MAX	UNIT
$I_{DD1}(SB)^{4,7}$	Supply current standby @ 0Hz (per die)	CMOS inputs, $I_{OUT} = 0$ $\overline{En} = V_{DD2} - 0.2$ $V_{DD1} = V_{DD1}(\max), V_{DD2} = V_{DD2}(\max)$	-55°C and 25°C	15	mA
			105°C	35	mA
$I_{DD2}(SB)^7$	Supply current standby @ 0Hz (per die)	CMOS inputs, $I_{OUT} = 0$ $\overline{En} = V_{DD2} - 0.2$ $V_{DD1} = V_{DD1}(\max), V_{DD2} = V_{DD2}(\max)$		3	mA
$I_{DD1}(SB)^{4,6,7}$	Supply current standby A(16:0) @ fmax (per die)	CMOS inputs, $I_{OUT} = 0$ $\overline{En} = V_{DD2} - 0.2$ $V_{DD1} = V_{DD1}(\max), V_{DD2} = V_{DD2}(\max)$	-55°C and 25°C	15	mA
			105°C	35	mA
$I_{DD2}(SB)^{6,7}$	Supply current standby A(16:0) @ fmax (per die)	CMOS inputs, $I_{OUT} = 0$ $\overline{En} = V_{DD2} - 0.2$ $V_{DD1} = V_{DD1}(\max), V_{DD2} = V_{DD2}(\max)$		3	mA

CAPACITANCE

SYMBOL	PARAMETER	CONDITION	UT8R1M39		UT8R2M39		UT8R4M39		UNIT
			MIN	MAX	MIN	MAX	MIN	MAX	
C_{IN}^1	Input capacitance	$f = 1\text{MHz} @ 0V$		18		29		50	pF
C_{En}^1	Input capacitance Device Enables	$f = 1\text{MHz} @ 0V$		10		10		10	pF
C_{IO}^1 DQ(31:0)	Bidirectional I/O capacitance	$f = 1\text{MHz} @ 0V$		15		27		50	pF
C_{IO}^1 TOP and BOT DQ(38:32)	Bidirectional I/O capacitance	$f = 1\text{MHz} @ 0V$		10		20		32	pF

Notes:

- * For devices procured with a total ionizing dose tolerance guarantee, the post-irradiation performance is guaranteed at 25°C per MIL-STD-883 Method 1019, Condition A up to the maximum TID level procured.
- 1. Measured only for initial qualification and after process or design changes that could affect this parameter.
- 2. Supplied as a design limit but not guaranteed nor tested.
- 3. Not more than one output may be shorted at a time for maximum duration of one second.
- 4. Post radiation limits are the 105°C temperature limit when specified.
- 5. Operating current limit does not include standby current.
- 6. fmax = 50MHz.
- 7. $V_{IH} = V_{DD2}(\max), V_{IL} = 0V$.

AC CHARACTERISTICS READ CYCLE (Pre and Post-Radiation)*

($V_{DD1} = 1.7V$ to $2.0V$, $V_{DD2} = 2.3V$ to $3.6V$; Unless otherwise noted, T_c is per the temperature range ordered.)

SYMBOL	PARAMETER	UT8R1M39		UT8R2M39		UT8R4M39		UNIT	FIGURE
		MIN	MAX	MIN	MAX	MIN	MAX		
t_{AVAV1}^1	Read cycle time	20		22		25		ns	3a
t_{AVQV}	Address to data valid from address change		20		22		25	ns	3c
t_{AXQX}^2	Output hold time	3		3		3		ns	3a
$t_{GLQX}^{1,2}$	\overline{G} -controlled output enable time	2		2		2		ns	3c
t_{GLQV}	\overline{G} -controlled output data valid		8		8		10	ns	3c
t_{GHQZ}^2	\overline{G} -controlled output three-state time	2	6	2	6	1	8	ns	3c
t_{ETQX}^2	E-controlled output enable time	5		5		5		ns	3b
t_{ETQV}	E-controlled access time		20		22		25	ns	3b
t_{EFQZ}^2	E-controlled output three-state time ²	2	7	2	7	2	7	ns	3b

Notes:

* For devices procured with a total ionizing dose tolerance guarantee, the post-irradiation performance is guaranteed at 25°C per MIL-STD-883 Method 1019, Condition A up to the maximum TID level procured

1. Guaranteed by characterization, but not tested.
2. Three-state is defined as a change from steady-state output voltage.

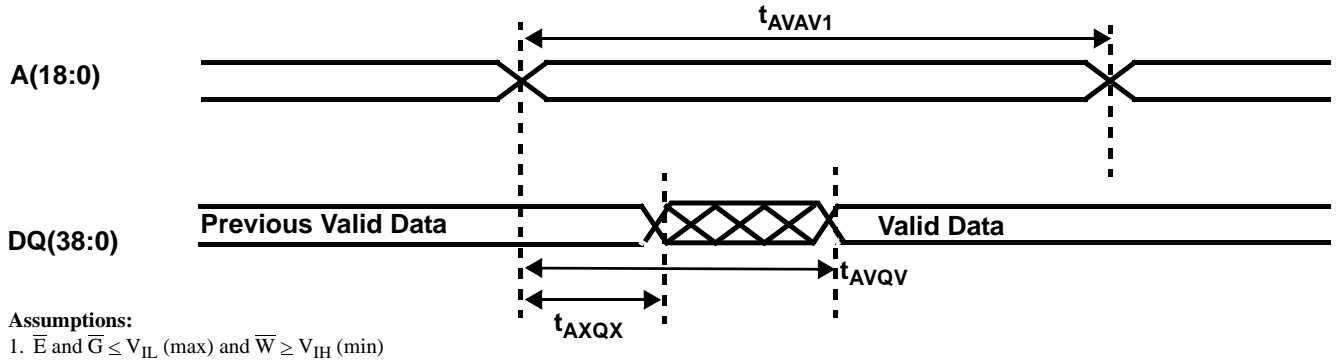

Figure 3a. SRAM Read Cycle 1: Address Access

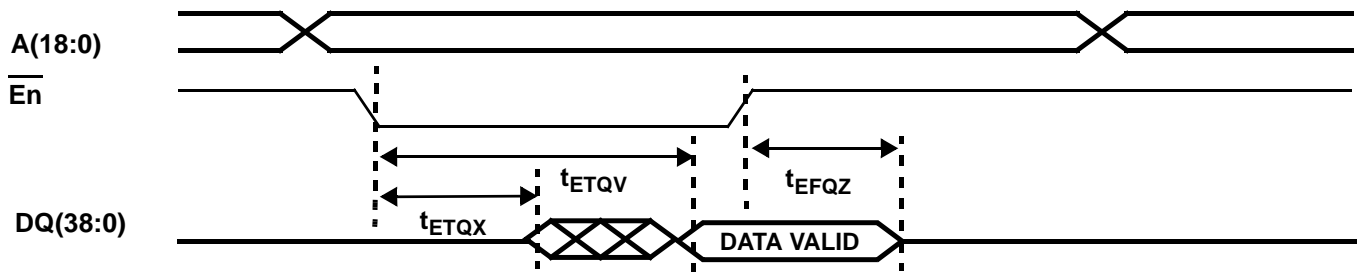

Figure 3b. SRAM Read Cycle 2: Chip Enable-Controlled Access

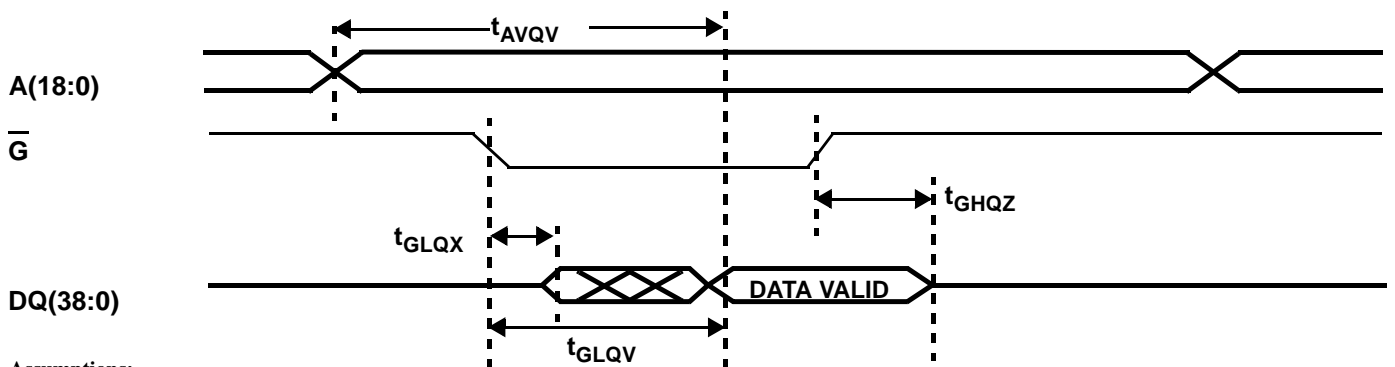

Figure 3c. SRAM Read Cycle 3: Output Enable Access

AC CHARACTERISTICS WRITE CYCLE (Pre and Post-Radiation)*

($V_{DD1} = 1.7V$ to $2.0V$, $V_{DD2} = 2.3V$ to $3.6V$; Unless otherwise noted, T_c is per the temperature range ordered.)

SYMBOL	PARAMETER	UT8R1M39		UT8R2M39		UT8R4M39		UNIT	FIGURE
		MIN	MAX	MIN	MAX	MIN	MAX		
t_{AVAV2}^1	Write cycle time	10		10		10		ns	4a/4b
t_{ETWH}	Device enable to end of write	10		10		10		ns	4a
t_{AVET}	Address setup time for write ($\overline{E_n}$ - controlled)	0		0		0		ns	4b
t_{AVWL}	Address setup time for write (\overline{W} - controlled)	0		0		0		ns	4a
t_{WLWH}^1	Write pulse width	8		8		8		ns	4a
t_{WHAX}	Address hold time for write (\overline{W} - controlled)	0		0		0		ns	4a
t_{EFAX}	Address hold time for device enable ($\overline{E_n}$ - controlled)	0		0		0		ns	4b
t_{WLQZ}^2	\overline{W} - controlled three-state time		7		7		9	ns	4a/4b
t_{WHQX}^2	\overline{W} - controlled output enable time	0		0		0		ns	4a
t_{ETEF}	Device enable pulse width ($\overline{E_n}$ - controlled)	10		10		10		ns	4b
t_{DVWH}	Data setup time	5		5		6		ns	4a
t_{WHDX}	Data hold time	0		0		0		ns	4a
t_{WLEF}^1	Device enable controlled write pulse width	8		8		8		ns	4b
t_{DVEF}	Data setup time	5		5		6		ns	4a/4b
t_{EFDX}	Data hold time	0		0		0		ns	4b
t_{AVWH}	Address valid to end of write	10		10		10		ns	4a
t_{WHWL}^1	Write disable time	2		2		3		ns	4a

Notes:

* For devices procured with a total ionizing dose tolerance guarantee, the post-irradiation performance is guaranteed at 25°C per MIL-STD-883 Method 1019, Condition A up to the maximum TID level procured

1. Tested with \overline{G} high.

2. Three-state is defined as a change from steady-state output voltage.

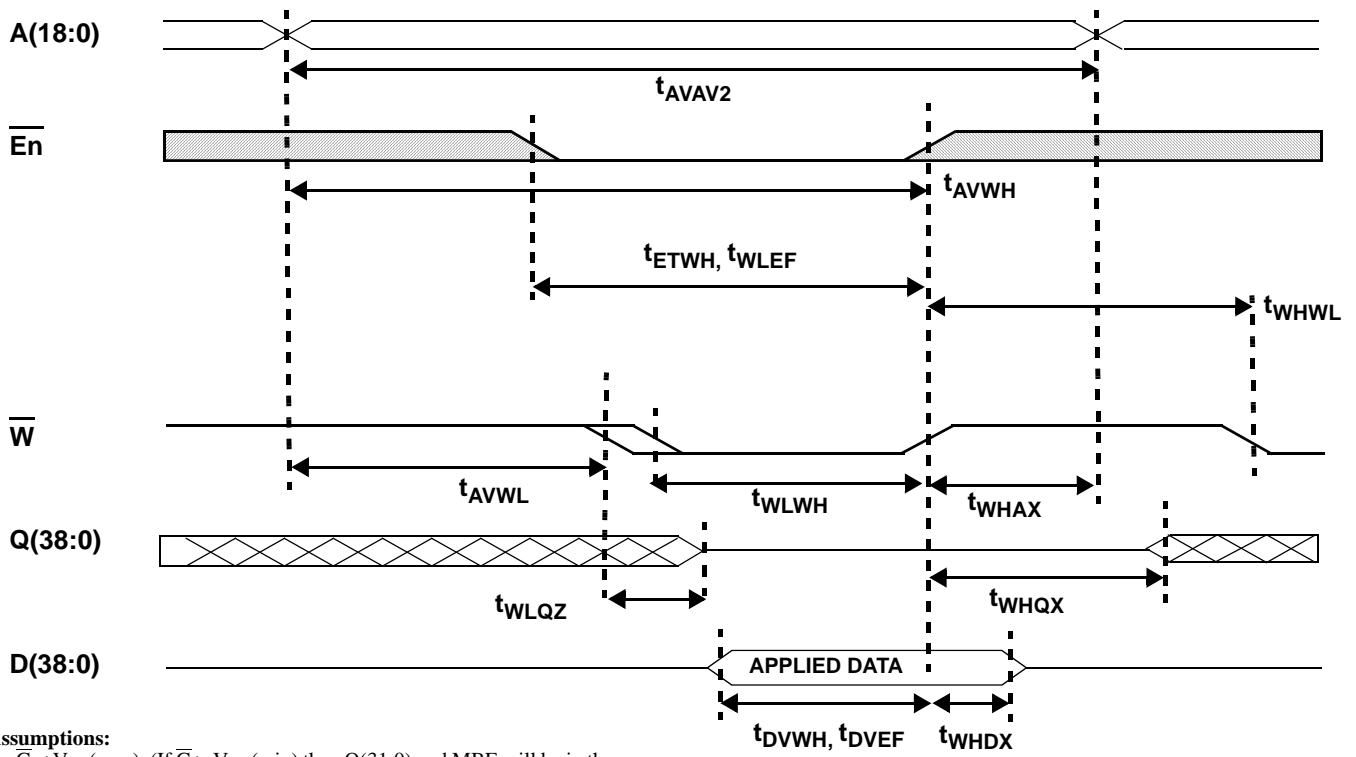

Assumptions:

1. $\overline{G} \leq V_{IL}(\text{max})$. (If $\overline{G} \geq V_{IH}(\text{min})$ then Q(31:0) and MBE will be in three-state for the entire cycle.)
2. $\overline{SCRUB} \geq V_{OH}(\text{min})$

Figure 4a. SRAM Write Cycle 1: \overline{W} - Controlled Access

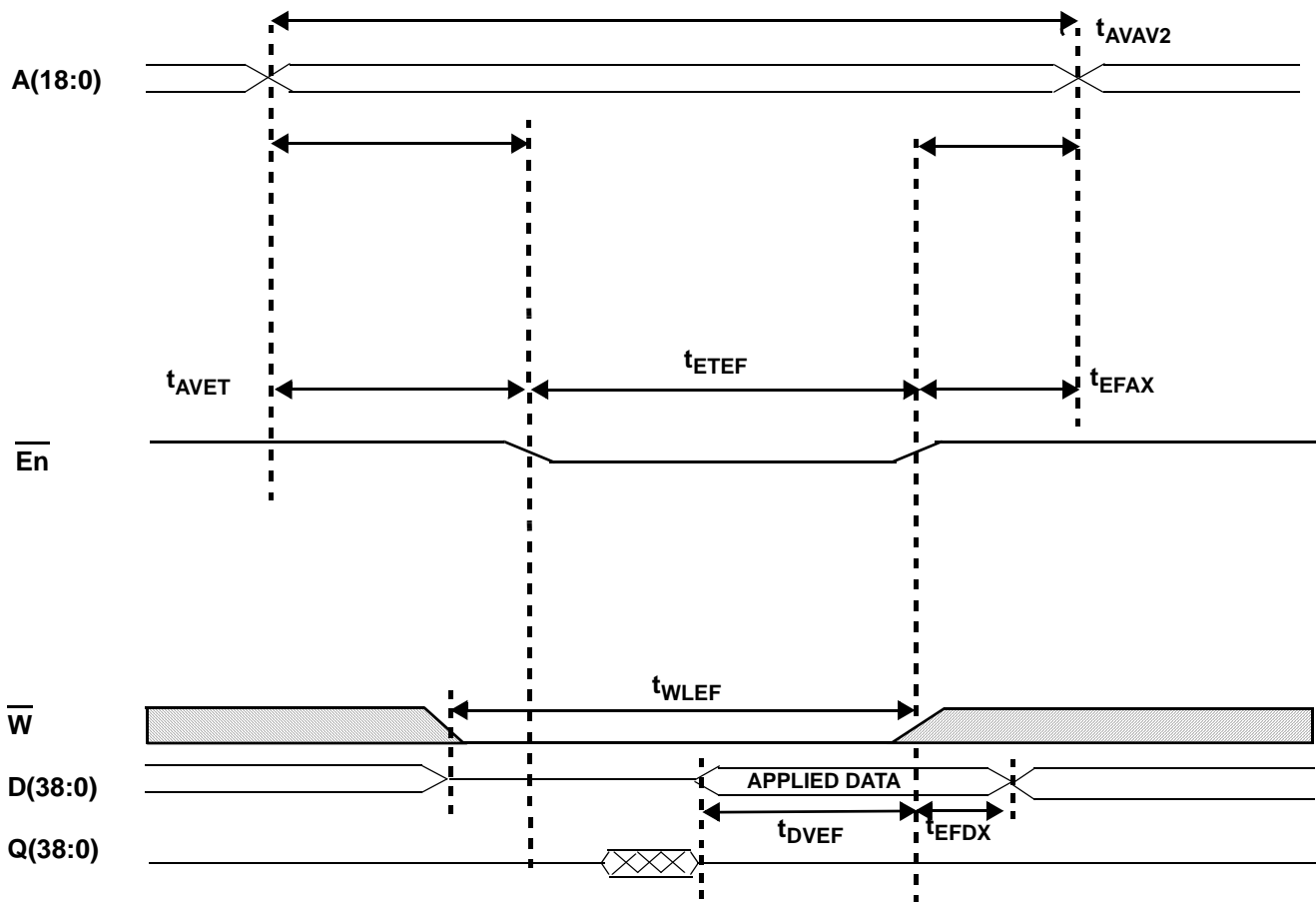

Assumptions & Notes:

1. $\overline{G} \leq V_{IL}(\text{max})$. (If $\overline{G} \geq V_{IH}(\text{min})$ then Q(31:0) and MBE will be in three-state for the entire cycle.)
2. $\overline{\text{Busy}} \geq V_{OH}(\text{min})$

Figure 4b. SRAM Write Cycle 2: Enable - Controlled Access

DATA RETENTION CHARACTERISTICS (Pre and Post-Radiation)*
($V_{DD2} = 2.3$ to $3.6V$, 1 second DR pulse)

SYMBOL	PARAMETER	TEMP	MINIMUM	MAXIMUM	UNIT
V_{DR}	V_{DD1} for data retention	--	1.0	--	V
I_{DDR}^1	Data retention current (per die)	-55°C	--	3	mA
		25°C	--	3	mA
		105°C	--	23.5	mA
$t_{EFR}^{1,2}$	Chip deselect to data retention time	--	0	--	ns
$t_R^{1,2}$	Operation recovery time	--	t_{AVAV1}	--	ns
		--	t_{AVAV2}	--	ns

- Notes:**
 * Post-radiation performance guaranteed at 25°C per MIL-STD-883 Method 1019.
 1. En as shown all other inputs = V_{DD2} or V_{SS} .
 2. Guaranteed by design neither tested nor characterized.

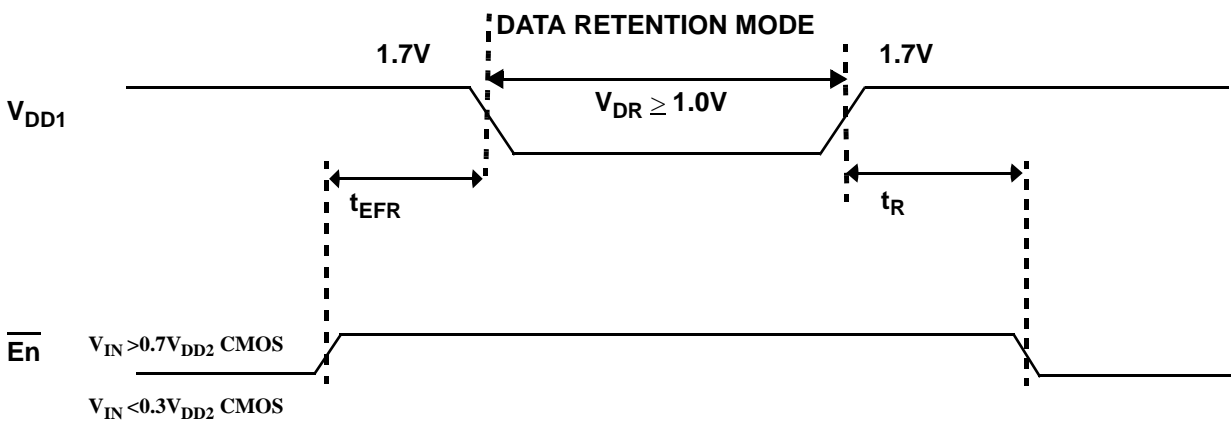
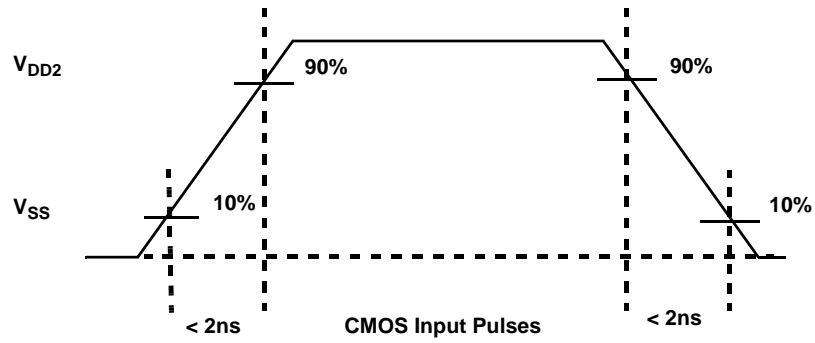
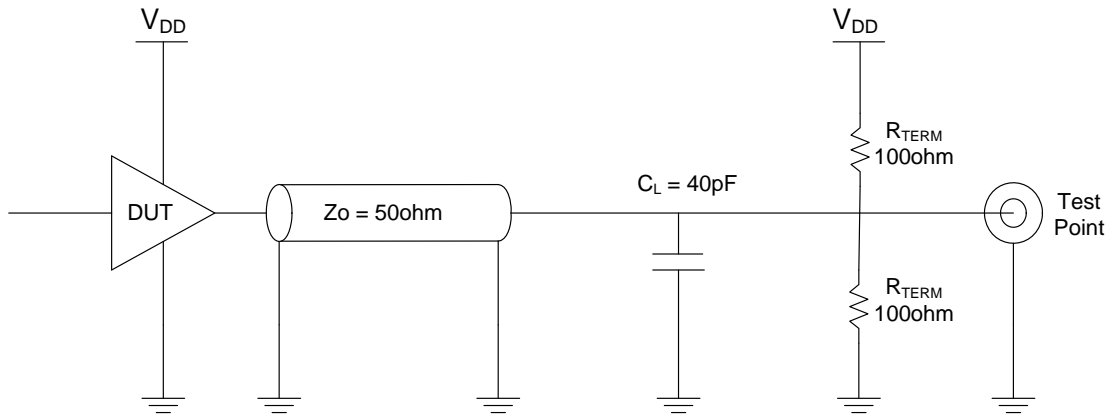

Figure 5. Low V_{DD} Data Retention Waveform



Notes:

1. Measurement of data output occurs at the low to high or high to low transition mid-point (i.e., CMOS input = $V_{\text{DD}2}/2$)

Figure 6. AC Test Loads and Input Waveforms

PACKAGING

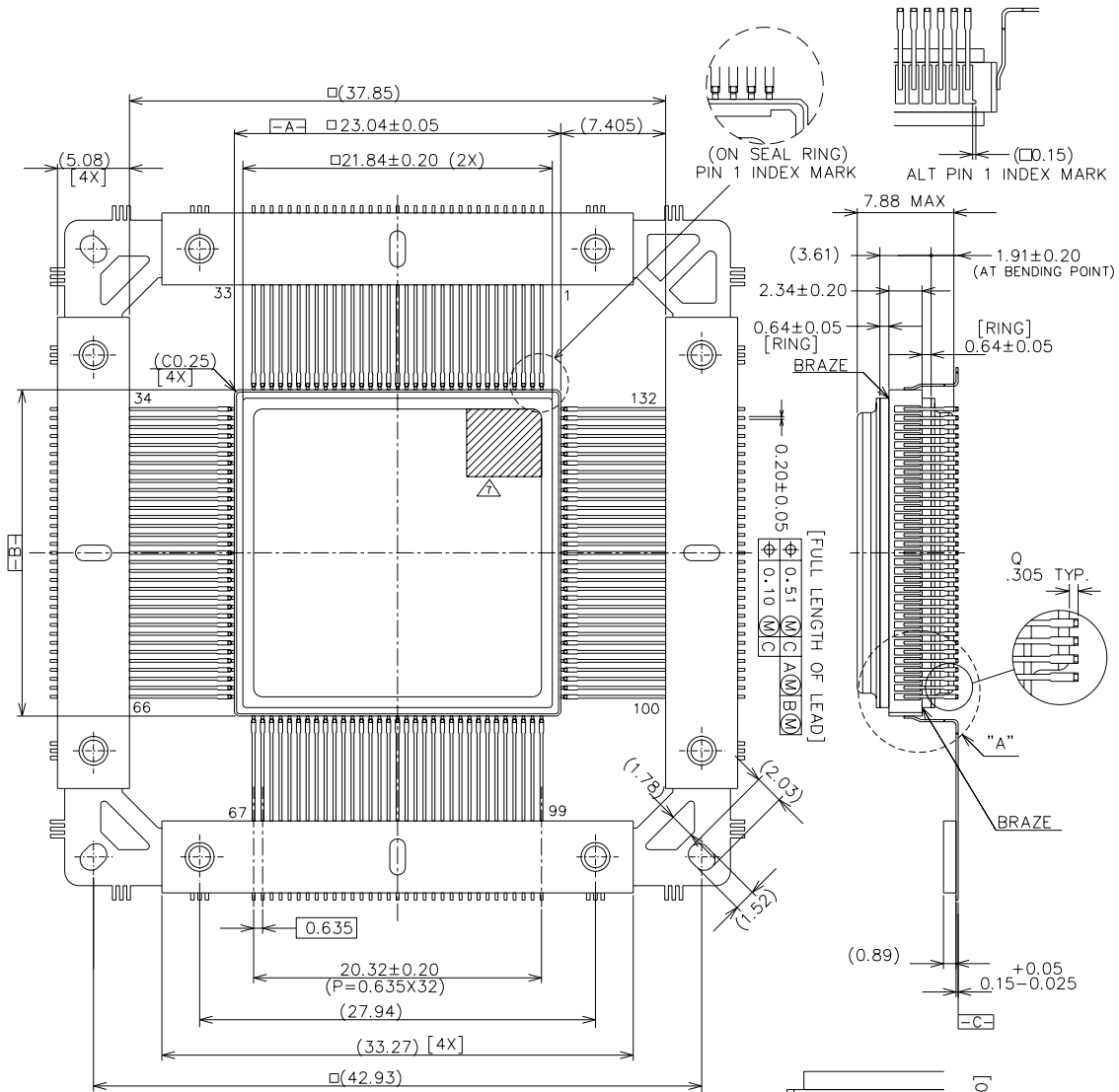

NOTES:

1. PACKAGE MATERIAL: OPAQUE 90% MINIMUM ALUMINA CERAMIC.
2. ALL EXPOSED METAL AREAS MUST BE GOLD PLATED
2.5um TO 5.7um THICK OVER ELECTROPLATED NICKEL
UNDERCOATING 2.5um TO 8.9um THICK PER MIL-PRF-38535.
3. THE SEAL RING IS ELECTRICALLY CONNECTED TO VSS.
4. DOGLEG GEOMETRIES OPTIONAL WITHIN DIMENSIONS SHOWN.
5. TIEBAR MAY HAVE EXCIZE SLOTS OF VARIOUS CONFIGURATIONS AND ARE VENDOR OPTION.
6. CIRCLED LETTERS ARE FOR AEROFLEX USE ONLY.
7. PACKAGE MARK WILL INCLUDE A DOT TO INDICATE THE PIN 1 CORNER WITHIN THE AREA SHOWN.
8. SEAL RING TO BE CONNECTED TO VSS.

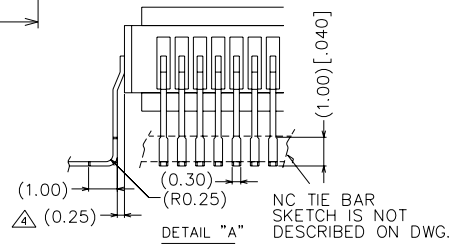

355/A

Figure 7. 132-Lead Side-Brazed Dual Cavity Ceramic Quad Flatpack

ORDERING INFORMATION

40Mbit (1Mx39) SRAM MCM
80Mbit (2Mx39) SRAM MCM
160Mbit (4Mx39) SRAM MCM

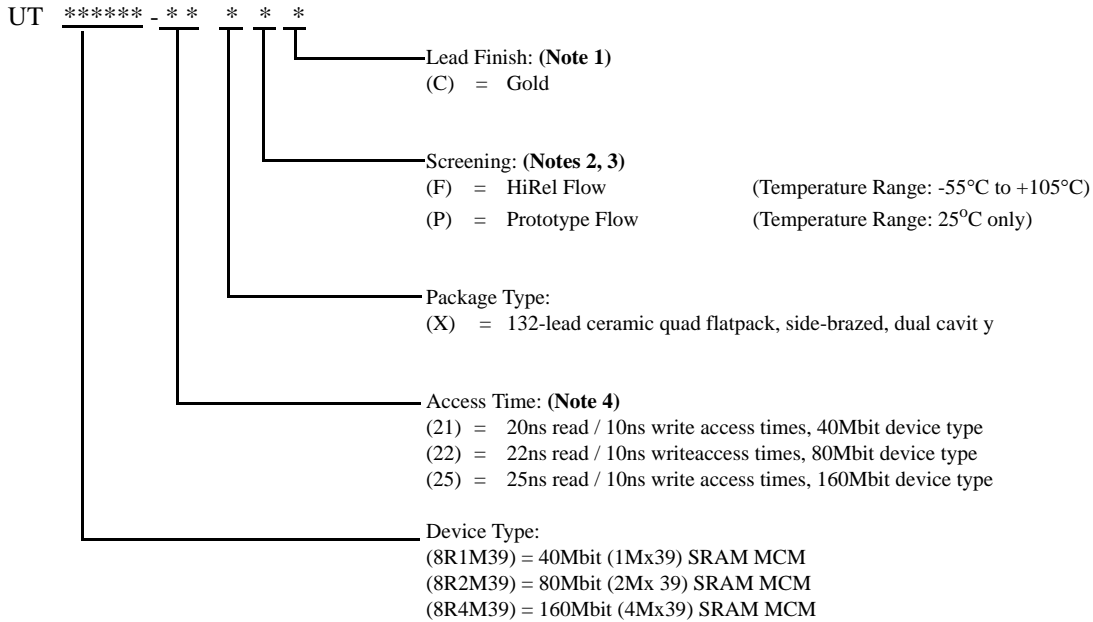

Notes:

1. Lead finish is "C" (Gold) only.
2. Prototype Flow per Aeroflex Manufacturing Flows Document. Devices are tested at 25°C only. Lead finish is GOLD "C" only. Radiation is neither tested nor guaranteed.
3. HiRel flow per Aeroflex Manufacturing Flows Document. Radiation is neither tested nor guaranteed.
4. Device option (21) applicable to 40Mbit device type only. Option (22) applicable to 80Mbit device type only. Option (25) applicable to 160Mbit device type only.

40Mbit (1Mx39) SRAM MCM: SMD
80Mbit (2Mx39) SRAM MCM: SMD
160Mbit (4Mx39) SRAM MCM: SMD

5962 * ***** ** * * *

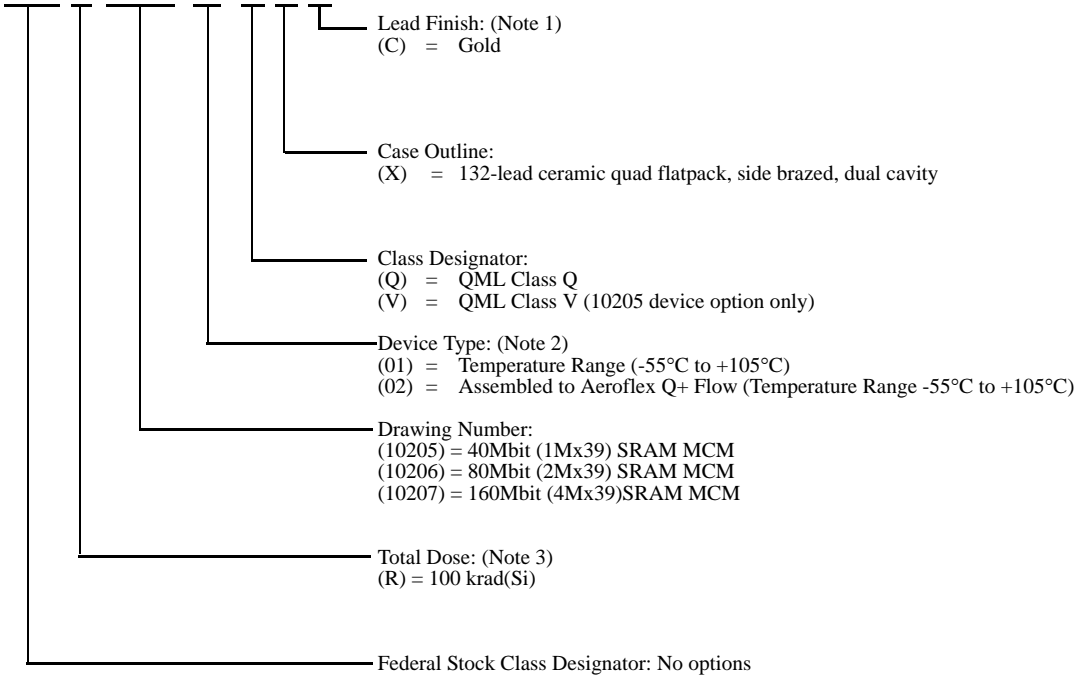

Notes:

1. Lead finish is "C" (Gold) only.
2. Aeroflex's Q+ assembly flow, as defined in section 4.2.2.d of the SMD, provides QML-Q product through the SMD that is manufactured with Aeroflex's standard QML-V flow and has completed QML-V qualification per MIL-PRF-38535.
3. TID tolerance guarantee of 1E5 is tested in accordance with MIL-STD-883 Test Method 1019 (condition A and section 3.11.2) resulting in an effective dose rate of 1 rad(Si)/sec.

Aeroflex Colorado Springs - Datasheet Definition

Advanced Datasheet - Product In Development

Preliminary Datasheet - Shipping Prototype

Datasheet - Shipping QML & Reduced Hi-Rel

COLORADO

Toll Free: 800-645-8862
Fax: 719-594-8468

INTERNATIONAL

Tel: 805-778-9229
Fax: 805-778-1980

NORTHEAST

Tel: 603-888-3975
Fax: 603-888-4585

SE AND MID-ATLANTIC

Tel: 321-951-4164
Fax: 321-951-4254

WEST COAST

Tel: 949-362-2260
Fax: 949-362-2266

CENTRAL

Tel: 719-594-8017
Fax: 719-594-8468

www.aeroflex.com info-ams@aeroflex.com

Aeroflex Colorado Springs, Inc., reserves the right to make changes to any products and services herein at any time without notice. Consult Aeroflex or an authorized sales representative to verify that the information in this data sheet is current before using this product. Aeroflex does not assume any responsibility or liability arising out of the application or use of any product or service described herein, except as expressly agreed to in writing by Aeroflex; nor does the purchase, lease, or use of a product or service from Aeroflex convey a license under any patent rights, copyrights, trademark rights, or any other of the intellectual rights of Aeroflex or of third parties.



Our passion for performance is defined by three attributes represented by these three icons: solution-minded, performance-driven and customer-focused