

January 11, 2007



FEATURES

- Upscreened PMC-Sierra RM7065C
- Military and Industrial Grades Available
- Dual issue symmetric superscaler microprocessor with instruction prefetch optimized for system level price/performance
 - o 450MHz operating frequency
- High-performance system interface
 - o Multiplexed address/data bus (SysAD) supports 2.5V, 3.3V I/O logic
 - o Processor clock multipliers 2, 2.5, 3, 3.5, 4, 4.5, 5, 6, 7, 8, 9
 - o Support for 64-bit or 32-bit external agents
- Integrated primary and secondary caches
 - o All are 4-way set associative with 32-byte line size
 - o 16-Kbytes instruction, 16-Kbytes data, 256-Kbytes on-chip secondary
 - o Per line cache locking in primaries and secondary
 - o Fast Packet Cache™ increases system efficiency in networking applications
- High-performance floating-point unit — 1600MFLOPS maximum
 - o Single cycle repeat rate for common single-precision operations and some double-precision operations
 - o Single cycle repeat rate for single-precision combined multiply-add operations
 - o Two cycle repeat rate for double-precision multiply and double-precision combined multiply-add operations
- MIPS IV superset instruction set architecture
 - o Data PREFETCH instruction allows the processor to overlap cache miss latency and instruction execution
 - o Single-cycle floating-point multiply-add
- Integrated memory management unit
 - o Fully associative joint TLB (shared by I and D translations)
 - o 64/48 dual entries map 128/96 pages
 - o Variable page size
- Embedded application enhancements
 - o Specialized DSP integer Multiply-Accumulate instructions, (MAD/MADU) and three-operand multiply instruction (MUL)
 - o I&D Test/Break-point (Watch) registers for emulation & debug
 - o Performance counter for system and software tuning & debug
 - o Fourteen fully prioritized vectored interrupts — 10 external, 2 internal, 2 software
- Fully static CMOS design with dynamic power down logic
- 216-EPad LQFP 24x24mm are pin compatible with the RM7965 and RM5261A EPad™ products

NOTE: 216-Enhanced Pad package, EPad MIPS64 and Fast Packet Cache are Trademarks of PMC-Sierra

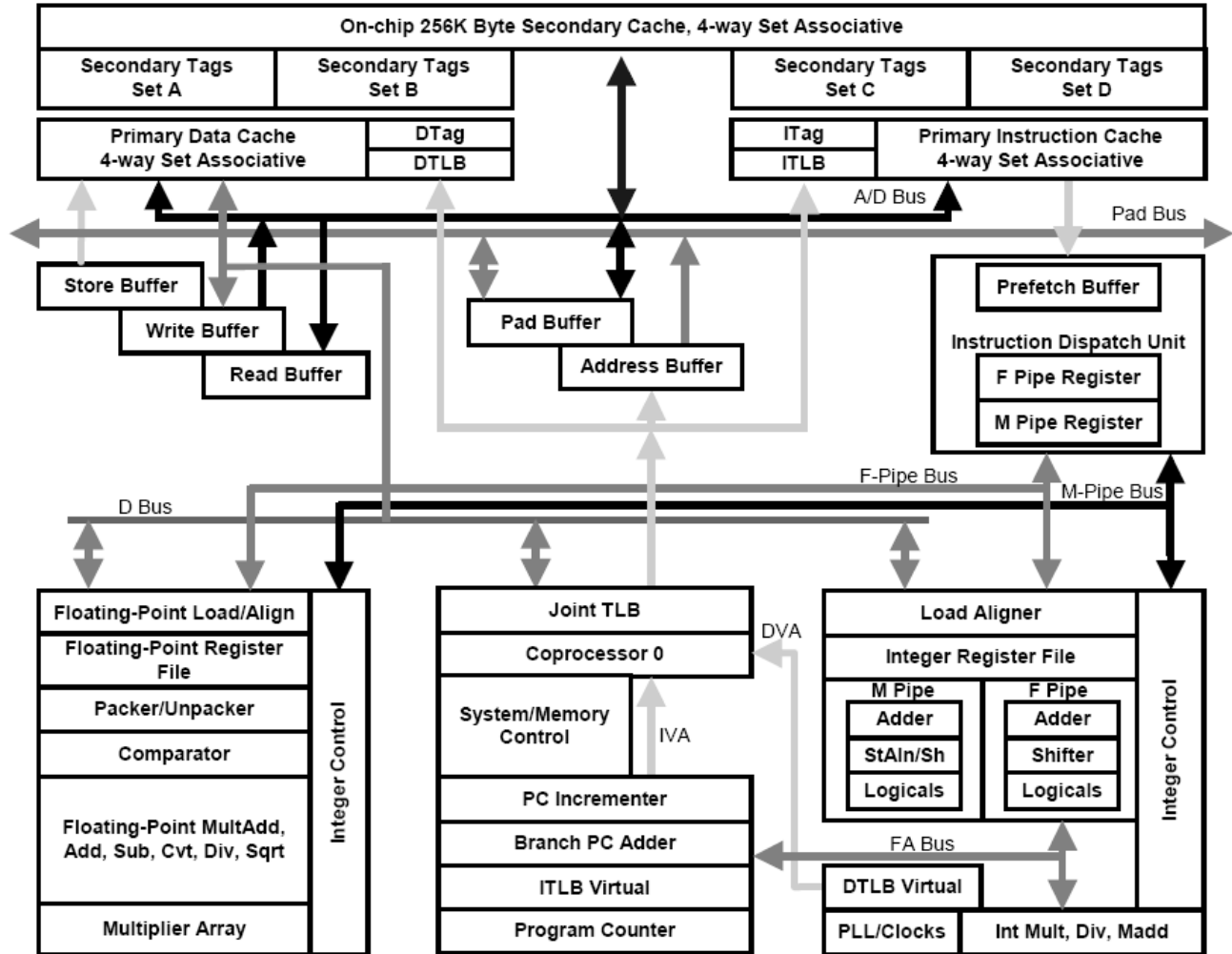

BLOCK DIAGRAM

DESCRIPTION

The MIP7365 Microprocessor is a highly integrated symmetric superscalar microprocessor capable of issuing two instructions each processor cycle. It has two highperformance 64-bit integer units as well as a high-throughput, fully pipelined 64-bit floating point unit.

The MIP7365 integrates 16 Kbytes 4-way set associative instruction and data caches along with an integrated 256 Kbytes 4-way set associative secondary cache. The primary data and secondary caches are write-back and non-blocking.

The memory management unit contains a 64/48-entry fully associative TLB and a 64-bit system interface supporting multiple outstanding reads with out-of-order return and hardware prioritized and vectored interrupts.

The MIP7365 is available in a 216-EPad LQFP package. The 216-EPad package is pin compatible with previous RM7965 and the RM5261A ExposedPad products.

The MIP7365 ideally suits high-end embedded control applications such as internetworking, high-performance image manipulation, high-speed printing, and 3-D visualization. The MIP7365 is also applicable to the low end workstation market where its balanced integer and floating-point performance provides outstanding price/performance.

For additional Detail Information regarding the operation of the PMC-Sierra see the latest PMC-Sierra datasheet for the RM7065C Family Microprocessors Data Sheet, Issue No. 5: August 2006; Document No. PMC-2021816, Issue 5

PIN DESCRIPTIONS

The following is a list of control, data, clock, interrupt, and miscellaneous pins of MIP7365.

System Interface

PIN NAME	TYPE	DESCRIPTION
ExtRqst*	Input	External request Signals that the external agent is submitting an external request.
Release*	Output	Release interface Signals that the processor is releasing the system interface to slave state
RdRdy*	Input	Read Ready Signals that an external agent can now accept a processor read.
WrRdy*	Input	Write Ready Signals that an external agent can now accept a processor write request.
ValidIn*	Input	Valid Input Signals that an external agent is now driving a valid address or data on the bus and a valid command or data identifier on the SysCmd bus.
ValidOut*	Output	Valid output Signals that the processor is now driving a valid address or data on the SysAD bus and a valid command or data identifier on the SysCmd bus.
PRqst*	Output	Processor Request When asserted this signal requests that control of the system interface be returned to the processor. This is enabled by Mode Bit 26
PAck*	Input	Processor Acknowledge When asserted, in response to PRqst*, this signal indicates to the processor that it has been granted control of the system interface.
RspSwap*	Input	Response Swap RspSwap* is used by the external agent to signal the processor when it is about to return a memory reference out of order; i.e., of two outstanding memory references, the data for the second reference is being returned ahead of the data for the first reference. In order that the processor will have time to switch the address to the tertiary cache, this signal must be asserted a minimum of two cycles prior to the data itself being presented. Note that this signal works as a toggle; i.e., for each cycle that it is held asserted the order of return is reversed. By default, anytime the processor issues a second read it is assumed that the reads will be returned in order; i.e., no action is required if the reads are indeed returned in order. This is enabled by Mode Bit 26.
RdType	Output	Read Type During the address cycle of a read request, RdType indicates whether the read request is an instruction read or a data read.
SysAD[63:0]	Input/Output	System address/data bus A 64-bit address and data bus for communication between the processor and an external agent.
SysADC[7:0]	Input/Output	System address/data check bus An 8-bit bus containing parity check bits for the SysAD bus during data cycles.
SysCmd[8:0]	Input/Output	System command/data identifier bus A 9-bit bus for command and data identifier transmission between the processor and an external agent.
SysCmdP	Input/Output	System Command/Data Identifier Bus Parity For the MIP7365, unused on input and zero on output.

Clock/Control Interface

PIN NAME	TYPE	DESCRIPTION
Master Clock	Input	System clock Master clock input used as the system interface reference clock. All output timings are relative to this input clock. Pipeline operation frequency is derived by multiplying this clock up by the factor selected during boot initialization.

Power Supply

PIN NAME	TYPE	DESCRIPTION
VccInt	Input	Power supply for core.
VccIO	Input	Power supply for I/O.
VccP	Input	Vcc for PLL Quiet VccInt for the internal phase locked loop. Must be connected to VccInt through a filter circuit.
VccJ	Input	Power supply used for JTAG.
Vss	Input	Ground Return.
VssP	Input	Vss for PLL Quiet Vss for the internal phase locked loop. Must be connected to Vss through a filter circuit.

Interrupt Interface

PIN NAME	TYPE	DESCRIPTION
INT[9:0]*	Input	Interrupt Ten general processor interrupts, bit-wise ORed with bits 9:0 of the interrupt register.
NMI*	Input	Non-maskable interrupt Non-maskable interrupt, ORed with bit 15 of the interrupt register (bit 6 in R5000 compatibility mode).

JTAG Interface

PIN NAME	TYPE	DESCRIPTION
JTDI	Input	JTAG data in
JTCK	Input	JTAG clock input
JTDO	Output	JTAG data out
JTMS	Input	JTAG command
JTRST*	Input	JTAG reset.

Notes:

1. The **JTRST*** input was added to the RM70xxC and RM79xx CPUs to directly control the reset to the JTAG state machine. JTAG boundary scan test equipment must be able to drive **JTRST*** high to allow JTAG boundary scan operation.
2. The **JTRST*** input must be connected to GND (**Vss**) through a 220 Ω to 1 K Ω pull-down resistor to force the JTAG state machine into the reset state to allow normal operation (JTAG boundary scan mode disabled).
3. The JTAG interface electrical characteristics are dependent on the **VccJ** level chosen (2.5 V or 3.3 V).

Initialization Interface

PIN NAME	TYPE	DESCRIPTION
BigEndian	Input	Big Endian / Little Endian Control Allows the system to change the processor addressing
VccOK	Input	Vcc is OK When asserted, this signal indicates to the MIP7365 that the VccInt power supply has been above the recommended value for more than 100 milliseconds and will remain stable. The assertion of VccOK initiates the reading of the boot-time mode control serial stream.
ColdReset*	Input	Cold Reset This signal must be asserted for a power on reset or a cold reset. ColdReset must be de-asserted synchronously with SysClock.
Reset*	Input	Reset This signal must be asserted for any reset sequence. It may be asserted synchronously or asynchronously for a cold reset, or synchronously to initiate a warm reset. Reset must be de-asserted synchronously with SysClock.
ModeClock	Output	Boot Mode Clock Serial boot-mode data clock output at the system clock frequency divided by two hundred and fifty six.
Modein	Input	Boot Mode Data In Serial boot-mode data input.

ABSOLUTE MAXIMUM RATINGS¹

SYMBOL	RATING	RANGE	UNITS
V _{TERM}	Terminal Voltage with respect to V _{SS}	-0.5 ² to 3.9	V
T _c	Operating Temperature I = Industrial R = Extended T = Military M = Military, Screened	-40 to +85 -55 to +110 -55 to +125 -55 to +125	°C °C °C °C
T _{STG}	Storage Temperature	-55 to +125	°C
I _{IN}	DC Input Current	±20	mA
I _{OUT}	DC Output Current ⁴	±20	mA

Notes:

1. Stresses above those listed under "*AbsoluteMaximums Rating*" may cause permanent damage to the device. This is a stress rating only and functional operation of the device at these or any other conditions above those indicated in the operational sections of this specification is not implied. Exposure to absolute maximum rating conditions for extended periods may affect device reliability.
2. V_{IN} minimum = -2.0V for pulse width less than 15nS. V_{IN} maximum should not exceed +3.95 Volts.
3. When V_{IN} < 0V or V_{IN} > V_{CCIO}.
4. No more than one output should be shorted at one time. Duration of the short should not exceed more than 30 second.

RECOMMENDED OPERATING CONDITIONS

GRADE	CPU SPEED	TEMP (CASE)	V _{SS}	V _{CCInt}	V _{CCIO}	V _{CCP}	V _{CCJ}
Industrial	450 MHz	-40°C to +85°C	0 V	1.3 V ± 50 mV	3.3 V ± 150 mV or 2.5 V ± 200 mV	1.3 V ± 50 mV	3.3 V ± 150 mV or 2.5 V ± 200 mV
Extended	450 MHz	-55°C to +110°C	0 V	1.3 V ± 50 mV	3.3 V ± 150 mV or 2.5 V ± 200 mV	1.3 V ± 50 mV	3.3 V ± 150 mV or 2.5 V ± 200 mV
Military	450 MHz	-55°C to +125°C Note 5	0 V	1.3 V ± 50 mV	3.3 V ± 150 mV or 2.5 V ± 200 mV	1.3 V ± 50 mV	3.3 V ± 150 mV or 2.5 V ± 200 mV

Notes

1. V_{CCIO} should not exceed V_{CCInt} by greater than 2.5 V during the power-up sequence.
2. Applying a logic high state to any I/O pin before V_{CCInt} becomes stable is not recommended.
3. As specified in IEEE 1149.1 (JTAG), the JTMS pin must be held high during reset to avoid entering JTAG test mode. Refer to the RM7000 User Manual.
4. V_{CCP} must be connected to V_{CCInt} through a passive filter circuit. See RM7000 User Manual fo recommended circuit.
5. Contact factory for extended military temperature range products (CQFP hermetic MCM packages will be screened at -55°C to + 125°C).

DC ELECTRICAL CHARACTERISTICS

V_{ccIO} = 3.15 - 3.45V

PARAMETER	MINIMUM	MAXIMUM	CONDITIONS
V _{OL}	-	0.2V	I _{OUT} = 100μA
V _{OH}	V _{ccIO} - 0.2V	-	
V _{OL}	-	0.4V	I _{OUT} = 2mA
V _{OH}	2.4V	-	
V _{IL}	-0.3V	0.8V	-
V _{IH}	2.0V	V _{ccIO} + 0.3V	-
I _{IN}	-	±5μA	V _{IN} = 0
	-	±5μA	V _{IN} = V _{ccIO}

V_{ccIO} = 2.3V – 2.7V

PARAMETER	MINIMUM	MAXIMUM	CONDITIONS
V _{OL}	-	0.2V	I _{OUT} = 100μA
V _{OH}	2.1V	-	
V _{OL}	-	0.4V	I _{OUT} = 1mA
V _{OH}	2.0V	-	
V _{OL}	-	0.7V	I _{OUT} = 2mA
V _{OH}	1.7V	-	
V _{IL}	-0.3V	0.7V	-
V _{IH}	1.7V	V _{ccIO} + 0.3V	-
I _{IN}	-	±15μA	V _{IN} = 0
	-	±15μA	V _{IN} = V _{ccIO}

POWER CONSUMPTION

PARAMETER		CONDITIONS	CPU SPEED	
			450MHz (IND)	450MHz (MIL)
			MAX	MAX
V _{CCINT} Power (mWatts)	Standby		1350	1350
	Active	Maximum with no FPU operation ²	3100	3250
		Maximum worst case instruction mix	3250	3400

Notes:

1. Worst case supply voltage (maximum V_{ccInt}) with worst case temperature (maximum T_{CASE}).
2. Dhrystone 2.1 instruction mix.
3. I/O supply power is application dependant, but typically <20% of V_{ccInt}.

AC CHARACTERISTICS

CAPACITIVE LOAD DERATION

SYMBOL	PARAMETER	MINIMUM	MAXIMUM	UNITS	Mode
CLD	Load Derate	-	2	ns/25pF	LVTTL

CLOCK PARAMETERS

PARAMETER	SYMBOL	TEST CONDITIONS	BUS SPEED		UNITS
			LVTTL		
			MIN	MAX	
SysClock High	t_{SCHigh}	Transition $\leq 2ns$	3	-	ns
SysClock Low	t_{SCLow}	Transition $\leq 2ns$	3	-	ns
SysClock Frequency ¹			33.3	133	MHz
SysClock Period	t_{SCP}		7.5	30	ns
Clock Jitter for SysClock	$t_{JitterIn}$		-	± 150	ps
SysClock Rise Time	t_{SCRise}		-	2	ns
SysClock Fall Time	t_{SCFall}		-	2	ns
ModeClock Period	$t_{ModeCKP}$		-	256	ns
JTAG Clock Period	$t_{JTAGCKP}$		4	-	ns

Notes:

1. Operation of the MIP7365 is only guaranteed with the Phase Loop enabled.

SYSTEM INTERFACE PARAMETERS

PARAMETER ¹	SYM	TEST CONDITIONS ^{5,6}	I/O TYPE		UNITS
			LVTTL I/O		
			MIN	MAX	
Data Output ^{2,6,7}	t_{DO}	LVTTL ($V_{ccIO} = 3.3V$): mode[14:13] = 10 (fastest)	0.75	4.5	ns
		LVTTL ($V_{ccIO} = 3.3V$): mode[14:13] = 01 (slowest)	0.75	5.5	ns
Data Setup ⁴	t_{DS}	$t_{RISE} =$ See above table	2.5	-	ns
Data Hold ⁴	t_{DH}	$t_{FALL} =$ See above table	1.0	-	ns

Notes

1. In LVTTL mode, timings are measured from $0.425 \times V_{ccIO}$ of clock to $0.425 \times V_{ccIO}$ of signal for 3.3V I/O, and from $0.48 \times V_{ccIO}$ of clock to $0.48 \times V_{ccIO}$ of signal for 2.5V I/O. Input Rise/Fall time = 1V/1ns.
2. Capacitive load for all LVTTL maximum output timings is 50 pF. Minimum output timings are for theoretical no load conditions - untested.
4. Data Output timing applies to all signal pins whether tristate I/O or output only.
5. Setup and Hold parameters apply to all signal pins whether tristate I/O or input only.
6. Only mode 14:13 = 01 is tested and guaranteed.
7. Data shown is for 3.3 V I/O. For 2.5 V I/O: derate t_{DO} min by 0.25 nS, and t_{DO} max by 0.5 nS. Mode setting is mode [14:13] = 10 (fastest) or 01 (slowest).

TIMING DIAGRAMS

CLOCK TIMING

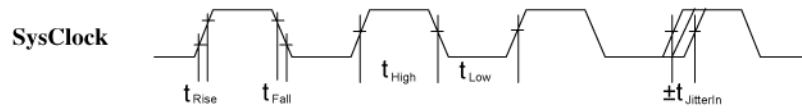

SYSTEM INTERFACE TIMING

(SysAD, SysCmd, ValidIn*, ValidOut*, etc.)

INPUT TIMING

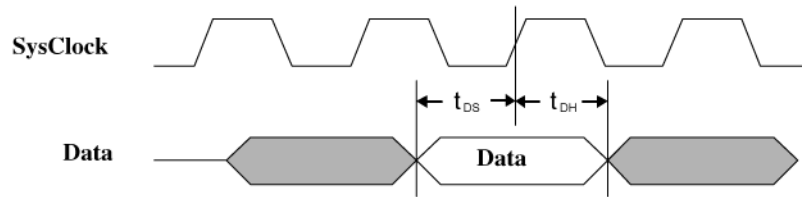

OUTPUT TIMING

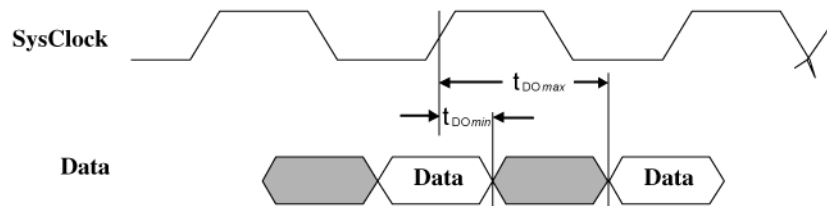

THERMAL INFORMATION

This product is designed to operate over a wide temperature range when used with a heat sink.

Maximum long-term operating junction temperature to ensure adequate long-term life	TBD at 450 MHz
Maximum junction temperature for short-term excursions with guaranteed continued functional performance	TBD at 450 MHz
Minimum ambient temperature	TBD

Device Compact Model ²	
θ_{JT} (°C/W)	4.19
θ_{JB} (°C/W)	5.43
θ_{JA} (°C/W)	11.65

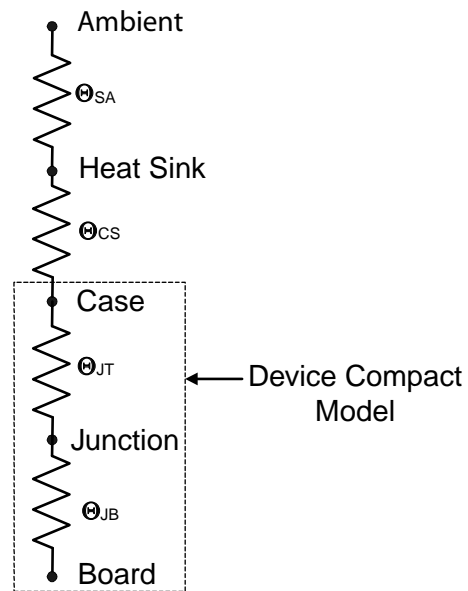

Operating power is dissipated in any package (watts) offered at worst case power supply		
Power at 450MHz	$V_{ccInt} = 1.3 \text{ V}, V_{ccIO} = 3.3 \text{ V}$	2.8W

Notes

1. Short-term is understood as the definition stated in Telcordia Generic Requirements GR-63-Core.
2. θ_{JC} , the junction-to-case thermal resistance, θ_{JB} , the junction-to-board thermal resistance are obtained from Package vendor.
3. θ_{SA} is the thermal resistance of the heat sink to ambient. θ_{CS} is the thermal resistance of the heat sink attached material.
4. The actual θ_{SA} required may vary according to the air speed at the location of the device in the system with all the components in place.

MIP7365 216-PIN EPad LQFP PACKAGE OUTLINE

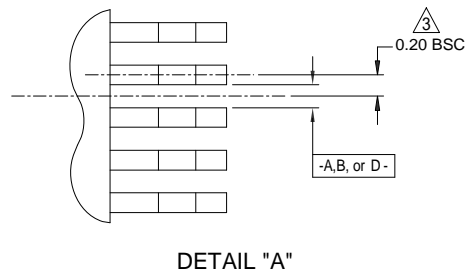
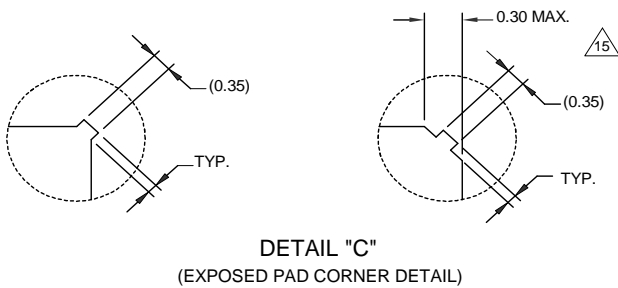
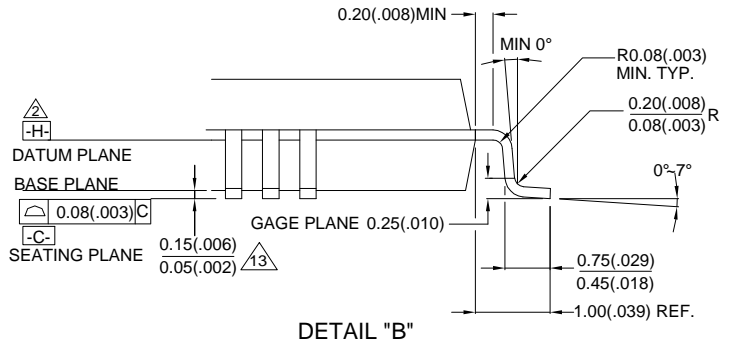
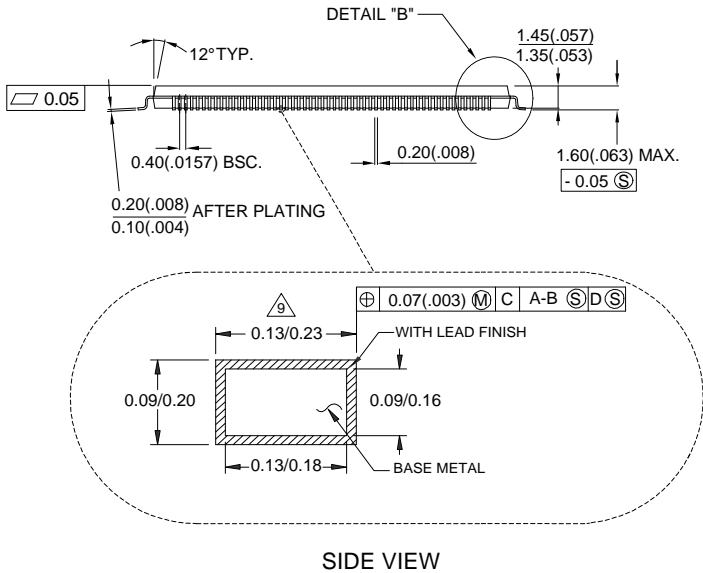
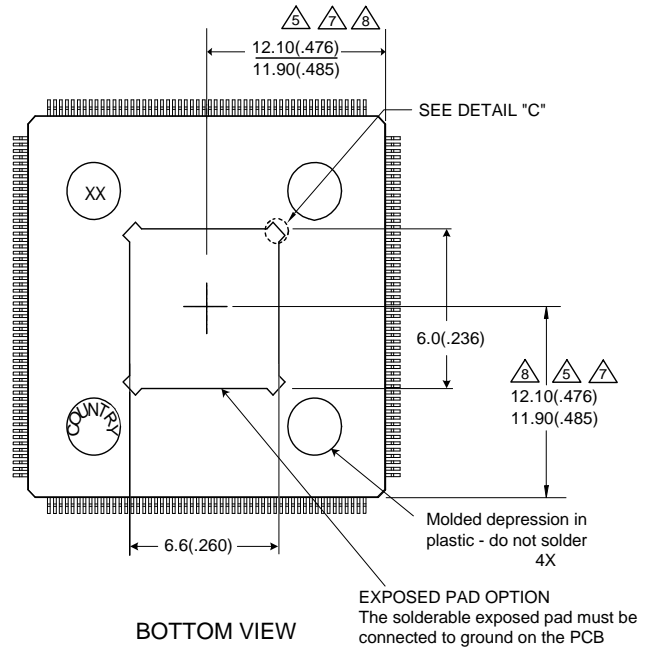
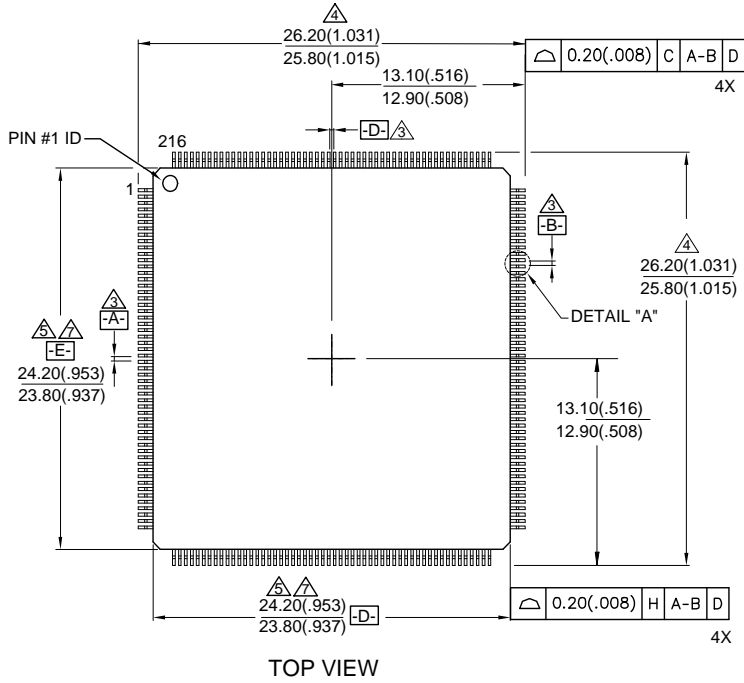

MIP7365 216-PIN EPad LQFP PACKAGE OUTLINE NOTES

Notes

1. All dimensions and tolerancing conform to ANSI Y14.5-1982. Inches are shown in parentheses.

△2. Datum plane -H- located at mold parting line and coincident with lead, where lead exits plastic body at bottom of parting line.

△3. Datums A-B and -D- to be determined at centerline between leads where leads exit plastic body at datum plane -H-.

△4. To be determined at seating plane -C-.

△5. Dimensions do not include mold protrusion. Allowable mold protrusion is 0.254 mm on dimensions.

6. 216 is the total number of terminals.

△7. These dimensions to be determined at datum plane -H-.

△8. Package top dimensions are smaller than bottom dimensions and top of package will not overhang bottom of package.

△9. Dimension does not include Dambar protrusion. Allowable Dambar protrusion shall be 0.08 mm total in excess of the dimension at maximum material condition. Dambar cannot be located on the lower radius or the foot.

10. Controlling dimension: millimeter.

11. Maximum allowable die thickness to be assembled in this package family is 0.38 mm.

12. This outline conforms to JEDEC publication 95, registration MS-026, variation BGB.

△13. Defined as the distance from the seating plane to the lowest point of the package body.

14. Exposed pad shall be coplanar with bottom of package within 0.05.

△15. Corner chamfer of exposed die pad shall be within 0.30 mm.

MIP7365 216-EPad LQFP NUMERICAL PINOUT vs FUNCTION 1,2

PIN	FUNCTION	PIN	FUNCTION	PIN	FUNCTION	PIN	FUNCTION
1	VccIO	39	SysAD48	77	VccIO	115	JTDO
2	Do Not Connect	40	SysAD16	78	SysCmd5	116	VccIO
3	Do Not Connect	41	VccInt	79	SysCmd4	117	ModeClock
4	Do Not Connect	42	BigEndian	80	SysCmd3	118	VccInt
5	Do Not Connect	43	VccIO	81	SysCmd2	119	PRQST*
6	VccInt	44	VccOK	82	VccInt	120	PACK*
7	SysAD59	45	ColdReset*	83	SysCmd1	121	RspSwap*
8	SysAD27	46	Reset*	84	SysCmd0	122	VccIO
9	SysAD58	47	ExtRqst*	85	Do Not Connect	123	VccInt
10	VccInt	48	NMI*	86	Do Not Connect	124	SysAD47
11	VccIO	49	VccInt	87	Do Not Connect	125	SysAD15
12	SysAD26	50	INT9*	88	VccInt	126	VccInt
13	VccInt	51	INT8*	89	Do Not Connect	127	SysAD46
14	SysAD57	52	INT7*	90	Do Not Connect	128	SysAD14
15	SysAD25	53	INT6*	91	VccInt	129	SysAD45
16	SysAD56	54	VccIO	92	Do Not Connect	130	SysAD13
17	SysAD24	55	VccJ	93	Do Not Connect	131	SysAD44
18	SysAD55	56	VccIO	94	Do Not Connect	132	SysAD12
19	SysAD23	57	INT5*	95	VccInt	133	VccInt
20	VccInt	58	INT4*	96	Do Not Connect	134	SysAD43
21	SysAD54	59	INT3*	97	Master Clock	135	SysAD11
22	SysAD22	60	INT2*	98	VssP	136	VccIO
23	SysAD53	61	INT1*	99	VccP	137	VccIO
24	SysAD21	62	INT0*	100	Release*	138	SysAD42
25	VccIO	63	VccInt	101	ValidOut*	139	SysAD10
26	VccIO	64	VccInt	102	ValidIn*	140	SysAD41
27	VccIO	65	Do Not Connect	103	WrRdy*	141	SysAD9
28	SysAD52	66	Do Not Connect	104	RdRdy*	142	VccInt
29	SysAD20	67	Do Not Connect	105	Do Not Connect	143	SysAD40
30	VccInt	68	VccIO	106	ModeIn	144	SysAD8
31	SysAD51	69	Do Not Connect	107	RdType	145	SysAD39
32	SysAD19	70	Do Not Connect	108	Do Not Connect	146	SysAD7
33	SysAD50	71	Do Not Connect	109	VccJ	147	SysAD38
34	SysAD18	72	VccInt	110	JTRST*	148	SysAD6
35	SysAD49	73	SysCmdP	111	VccIO	149	VccInt
36	SysAD17	74	SysCmd8	112	JTMS	150	SysAD37
37	VccIO	75	SysCmd7	113	JTCK	151	SysAD5
38	VccInt	76	SysCmd6	114	JTDI	152	SysAD36

MIP7365 216-EPad LQFP NUMERICAL PINOUT vs FUNCTION ^{1,2} CON'T

PIN	FUNCTION	PIN	FUNCTION
153	SysAD4	191	VccIO
154	VccInt	192	SysADC7
155	Do Not Connect	193	SysADC3
156	Do Not Connect	194	VccInt
157	VccInt	195	SysADC6
158	Do Not Connect	196	VccIO
159	Do Not Connect	197	SysADC2
160	Do Not Connect	198	SysAD63
161	Do Not Connect	199	SysAD31
162	VccIO	200	Do Not Connect
163	Do Not Connect	201	SysAD62
164	VccIO	202	SysAD30
165	VccIO	203	VccIO
166	Do Not Connect	204	VccIO
167	Do Not Connect	205	VccInt
168	Do Not Connect	206	SysAD61
169	Do Not Connect	207	SysAD29
170	SysAD35	208	VccInt
171	SysAD3	209	SysAD60
172	VccInt	210	SysAD28
173	SysAD34	211	Do Not Connect
174	SysAD2	212	Do Not Connect
175	VccInt	213	Do Not Connect
176	VccIO	214	Do Not Connect
177	VccInt	215	VccIO
178	SysAD33	216	VccIO
179	SysAD1		
180	SysAD32		
181	SysAD0		
182	SysADC5		
183	SysADC1		
184	VccIO		
185	VccInt		
186	SysADC4		
187	SysADC0		
188	Do Not Connect		
189	VccInt		
190	VccIO		

Notes:

1. The exposed pad on the bottom of the EPad LQFP package acts as the sole device ground and as the primary heat conduction path. As such, it must be soldered to the printed circuit board.
2. See PMC-[2030256](#), 216-EPad LQFP Design Guidelines Application Note for details.

SAMPLE ORDERING INFORMATION

PART NUMBER	SCREENING	PIPELINE FREQ (MHZ) Note 2	PACKAGE
MIP7365-450PI	Industrial Temperature Range -40°C to +85°C Testing	450	216-EPad LQFP
MIP7365-450PR	Extended Temperature Range -55°C to +110°C Testing Note 1		

Notes

1. Contact factory for extended military temperature range products (CQFP hermetic MCM package will be screened at -55°C to + 125°C).
2. Contact factory for higher speed product options.
3. Contact factory for availability.
4. The EEPad "M" pkg EOL is Nov 2006. The EPad LQFP "P" package is the replacement.

PART NUMBER BREAKDOWN

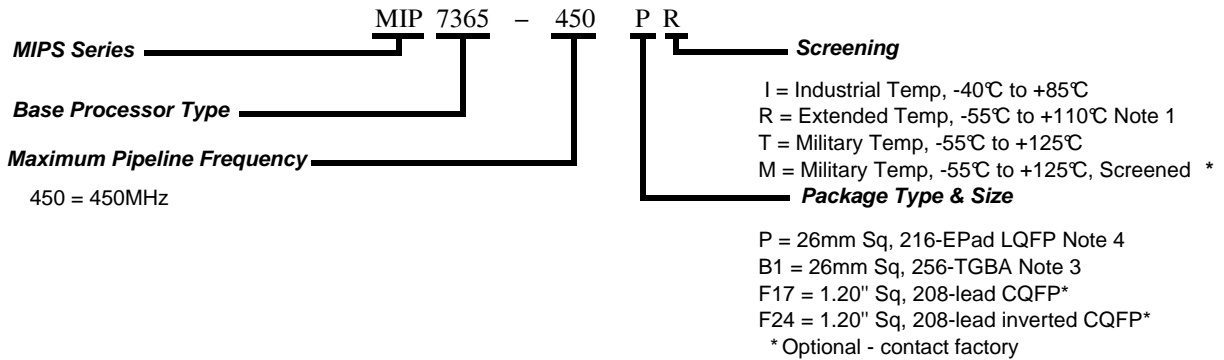

* Screened to the individual test methods of MIL-STD-883

PLAINVIEW, NEW YORK
 Toll Free: 800-THE-1553
 Fax: 516-694-6715

INTERNATIONAL
 Tel: 805-778-9229
 Fax: 805-778-1980

NORTHEAST
 Tel: 603-888-3975
 Fax: 603-888-4585

SE AND MID-ATLANTIC
 Tel: 321-951-4164
 Fax: 321-951-4254

WEST COAST
 Tel: 949-362-2260
 Fax: 949-362-2266

CENTRAL
 Tel: 719-594-8017
 Fax: 719-594-8468

www.aeroflex.com info-ams@eroflex.com

Aeroflex Microelectronic Solutions reserves the right to change at any time without notice the specifications, design, function, or form of its products described herein. All parameters must be validated for each customer's application by engineering. No liability is assumed as a result of use of this product. No patent licenses are implied. All trademarks are acknowledged. Parent company Aeroflex, Inc. 2003.



Our passion for performance is defined by three attributes represented by these three icons: solution-minded, performance-driven and customer-focused