

QQ-73

Digitally Controlled Analog Phase Shifters



Features

- 8 bit Digital logic standard
- Octave bands up to 18 GHz
- RF power operation 10 mW peak/CW, RF power survival 100mW peak/CW
- Custom configurations available

Specifications:

Parameter	Specification	Units
Frequency Range (min)	8.0 – 10.0	GHz
Phase Shift	180	Degrees
Insertion Loss (Max)	6	dB
Amplitude Ripple (Max)	1.0	±dB
VSWR (Max)	2.0:1	Ratio

Screening:

Internal Visual per MIL-STD-883, Method 2017
 Temperature Cycle: -65 °C to +100 °C, 10 cycles

Hermetically-sealed switches are fine and gross leak checked per MIL-STD-883, Method 1014.

Optional High-Rel screening available upon request. Contact the factory to discuss your screening requirements.

Environmental Specifications:

- Designed to meet:
- MIL-E-5400, MIL-STD-202, MIL-E-16400
 - Operating Temp: -0 °C to +60°C
 - Storage Temp: -65°C to +150°C
 - Humidity: MIL-STD-202F, M103, Cond B
 - Shock: MIL-STD-202F, M213, Cond B
 - Altitude: MIL-STD-202F, M105, Cond B
 - Vibration: MIL-STD-202F, M204, Cond B
 - Thermal Shock: MIL-STD-202F, M107, Cond A
 - Temperature Cycle: MIL-STD-202F, M105C, Cond D

Additional Electrical Specifications:

- DC Supply: +15 V ±0.5 V @ +50 mA
-15 V ±0.5 V @ -50 mA
- Control: 8 Bits command
- Logic Levels: TTL/HMOS

Mechanical Specifications:

- Case Style: QQ Outline
- Connectors: SMA Female per MIL-C-39012
- Connector Control: 15 Pin D
- Mounting: ø0.10" through holes (4) places



40 Industrial Way East, Eatontown, NJ 07724 [USA]
 Phone: (732) 460-0212, Fax: (732) 460-0214
 www.aeroflex.com/acc, email: acc-sales@eroflex.com

Outline Drawing:

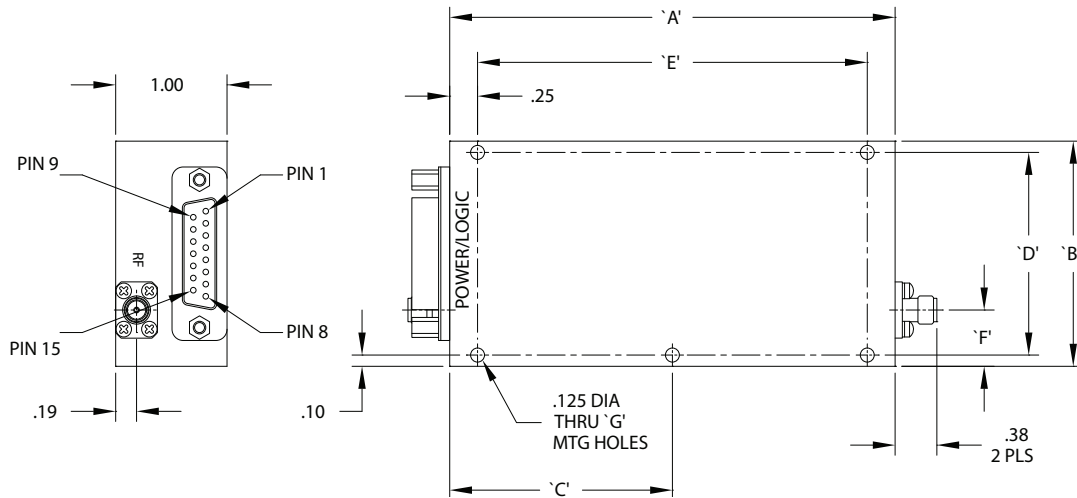

Outline	A'	B'	C'	D'	E'	F'	G'
4	3.00	2.00	1.50	1.80	2.50	0.30	3 PLCS

OUTLINE CASE STYLE QQ

Notes:

1. The voltages required are $\pm 15V @ 50mA$.
2. The Phase shift varies with frequency at any voltage setting. This variation, referenced to 0° at logic 0 for each frequency, is approximately $\pm 15\%$ for octave models, 10% for models with 25% bandwidth, and $\pm 7.5\%$ for models with 10% bandwidth. Phase flatness of the QQ-65 & QQ-74 is $\pm 25\%$.
3. Switching speed on all models is 200 nS .
4. Monotonicity is Guaranteed.
5. Least Significant BIT = Total Phase Shift divided by the number of steps. $8 \text{ BITS} = 256 \text{ steps}$.

Custom Options – Contact the Factory

- Gray epoxy paint per MIL-C-22750
- Video transient suppression
- GPO connectors
- ECL logic input
- Phase and amplitude tracking
- Other frequency ranges available from 1 MHz to 26 GHz
- Reversed logic
- Available without SMA connectors for drop-in applications
- High rel screening

Aeroflex Control Components
Aeroflex Microelectronic Solutions
40 Industrial Way East
Eatontown, NJ 07724 [USA]
Fax: (732) 460-0214

Sales
Phone: (732) 460-0212
ACC-sales@aeroflex.com

www.aeroflex.com/Microwave www.aeroflex.com/ACC

Aeroflex Control Components reserves the right to make changes to any products and services herein at any time without notice. Consult Aeroflex or an authorized sales representative to verify that the information in this data sheet is current before using this product. Aeroflex does not assume any responsibility or liability arising out of the application or use of any product or service described herein, except as expressly agreed to in writing by Aeroflex; nor does the purchase, lease, or use of a product or service from Aeroflex convey a license under any patent rights, copyrights, trademark rights, or any other of the intellectual rights of Aeroflex or of third parties.

Copyright 2011 Aeroflex Control Components. All rights reserved.

ISO 9001:2008 certified



Our passion for performance is defined by three attributes represented by these three icons: solution-minded, performance-driven and customer-focused.