

Mechanical Phase Shifters



Model 980 Coaxial Phase Shifters SMA Connectors

dc to 3.0/7.0/12.0 GHz
10 Watts

RoHS

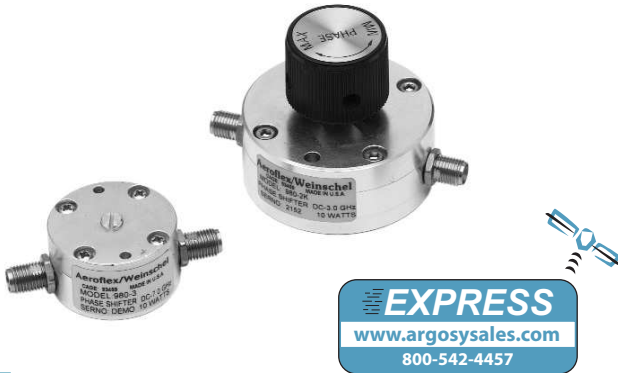

Features

- /// **Self Locking** - Internal mechanism eliminates the need for a locking nut. Ideal for phase trimming in densely packaged systems with minimum accessibility.
- /// **Available Express Models** - 980-2, 980-2K, 980-3, 980-4
Other models may be available for Express Delivery.
- /// **Linear** - Nominally linear phase over the frequency range.
- /// **Optimized for Wireless OEM Applications.**
- /// **New Models with Adjustment Knobs**
(See Models 980-1K through 980-4K).

Specifications

NOMINAL IMPEDANCE: 50 Ω

FREQUENCY RANGE:

Model 980-1 & 980-1K: dc to 3.0 GHz
 Model 980-2 & 980-2K: dc to 3.0 GHz
 Model 980-3 & 980-3K: dc to 7.0 GHz
 Model 980-4 & 980-4K: dc to 12.0 GHz

INCREMENTAL PHASE SHIFT (typical):

Model 980-1 & 980-1K: 140° @ 3.0 GHz
 Model 980-2 & 980-2K: 340° @ 3.0 GHz
 Model 980-3 & 980-3K: 170° @ 7.0 GHz
 Model 980-4 & 980-4K: 290° @ 12.0 GHz

Incremental phase shift is adjustable phase range over and above it's insertion phase

PHASE VS FREQUENCY: Nominally linear response

INSERTION PHASE:

Model 980-1 & 980-1K: 560° (Typical) @ 3.0 GHz
 Model 980-2 & 980-2K: 780° (Typical) @ 3.0 GHz
 Model 980-3 & 980-3K: 700° (Typical) @ 7.0 GHz
 Model 980-4 & 980-4K: 1200° (Typical) @ 12.0 GHz

MAXIMUM INSERTION LOSS (dB):

Model No.	Frequency Range (GHz)			
	1.5	3.0	7.0	12.0
980-1 & -1K	0.70 dB	1.20 dB	---	---
980-2 & -2K	1.50 dB	2.00 dB	---	---
980-3 & -3K	0.50 dB	0.50 dB	0.50 dB	---
980-4 & -4K	1.00 dB	1.00 dB	1.00 dB	1.00 dB

MAXIMUM SWR:

Frequency Range (GHz)	Model No.			
	980-1/1K	980-2/2K	980-3/3K	980-4/4K
dc - 3	1.30	1.35	1.30	1.30
3 - 7	---	---	1.30	1.30
7 - 12	---	---	---	1.60

POWER RATING: 10 watts average

TEMPERATURE RANGE:

Operating: -50°C to 85°C
 Storage: -50°C to 125°C

CONNECTOR: SMA female connector per MIL-STD-348 interface dimensions - mate nondestructively with MIL-C-39012 connector.

WEIGHT: Models 980-1 & 980-2: 65 g (2.29 oz)
 Models 980-1K & 980-2K: 78 g (2.75 oz)
 Model 980-3 & 980-4: 35 g (1.24 oz)
 Model 980-3K & 980-4K: 48 g (1.69 oz)

PHYSICAL DIMENSIONS:

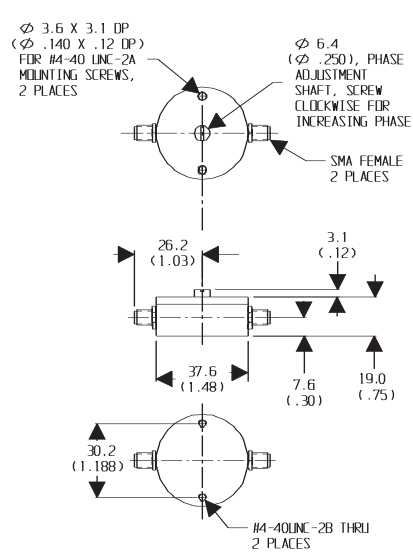

MODEL 980-1

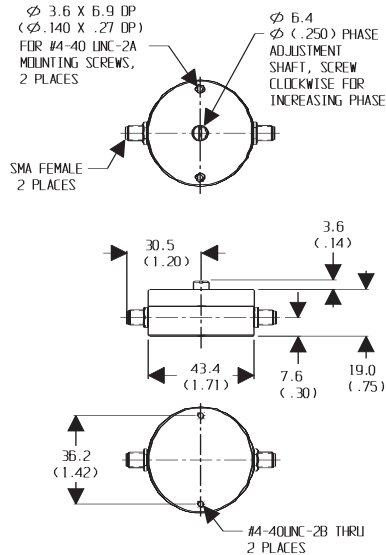

MODEL 980-2

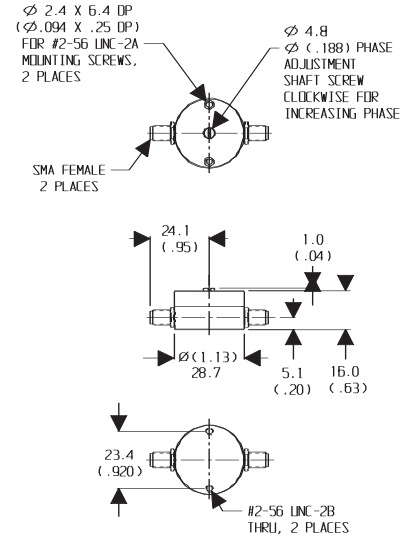

MODELS 980-3 & 980-4

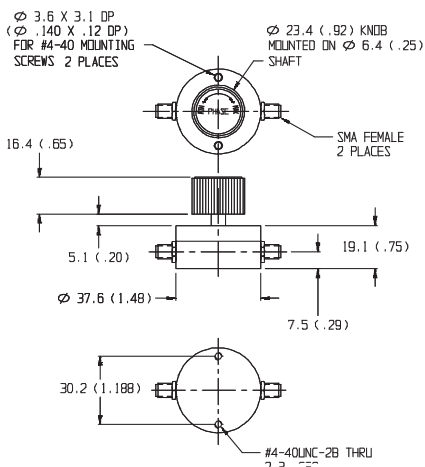

MODEL 980-1K

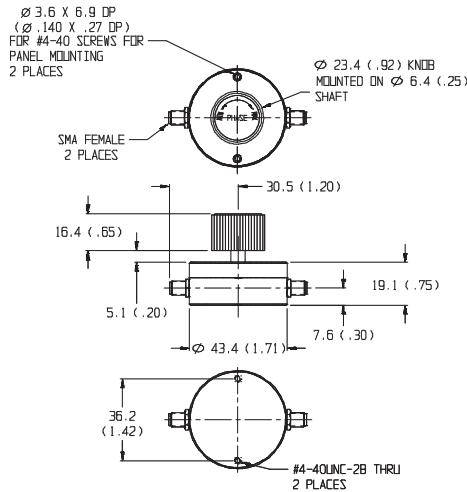

MODEL 980-2K

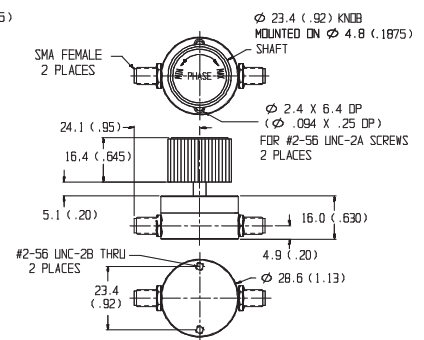

MODEL 980-3K & 980-4K

NOTE: All dimensions are given in mm (inches) and are maximum, unless otherwise specified.