

# Standard Products

## PCS5035 Quintet Precision Current Sources

### Built-In Comparators

Radiation Tolerant

[www.aeroflex.com/pcs](http://www.aeroflex.com/pcs)

September 12, 2012

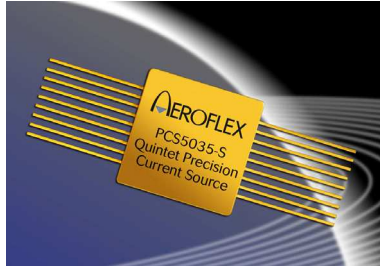

**AEROFLEX**  
A passion for performance.

## FEATURES

- Radiation Performance
  - Total dose  $\geq 100$  krad (Si), Dose rate = 50 - 300 rads(Si)/s
  - ELDRS  $\geq 15$  krads (Si), Dose rate = .01 rads(Si)/s
- Five high precision 80 $\mu$ A current source outputs/comparator inputs
- Monolithic construction
- Designed for thermistor temperature monitoring
- Enable control
- Long term stability
- Low drift
- Zener protected input
- DC supply voltage +5V
- Low supply current
- High impedance sensor interface
- Designed for aerospace and high reliability space applications
- 0.63" Sq x 0.125" Ht, 18 lead, hermetic flat package
- **Aeroflex Plainview's Radiation Hardness Assurance Plan is DLA Certified to MIL-PRF-38534, Appendix G.**

## GENERAL DESCRIPTION

The Aeroflex Plainview PCS5035 contains "Five Monolithic" precision current sources designed for thermistor current monitor and resistive sensor applications. The precision current source (80 $\mu$ A  $\pm$  2 $\mu$ A)/Comparator inputs are compared to an external reference of 0V<sub>DC</sub> to 3V<sub>DC</sub>. A precision internal 2.0V<sub>DC</sub> reference is provided if an external reference is not available. See Figure 1.

The comparator outputs of two (2) PCS5035 can be wired or 'ed to provide 10 sensors inputs. Current source output/comparator inputs of two or more units can be tied together to provide more sensor current. A logic "high" of 3.4V<sub>DC</sub> maximum on the enable pin turns on the current source/comparators. Any unused current source output/comparator inputs can be left open circuit without affecting other I/O's.

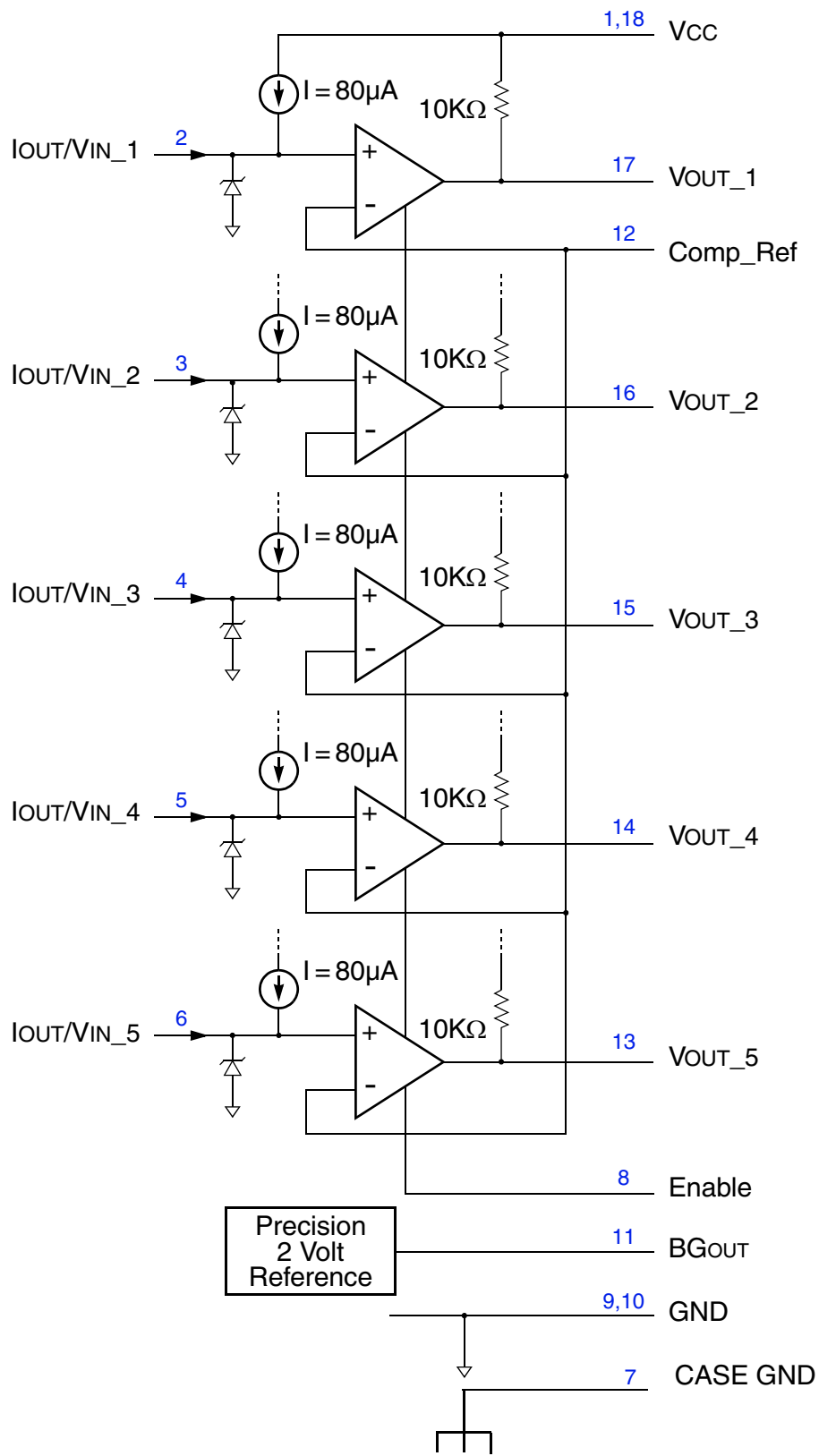

**FIGURE 1 – Schematic Diagram**

## ABSOLUTE MAXIMUM RATINGS

Parameter	Range	Units
Operating Case Temperature	-55 to +125	°C
Storage Case Temperature	-65 to +150	°C
Power Supply Voltages (VCC)	+7.0	V

NOTICE: Stresses above those listed under "Absolute Maximum Ratings" may cause permanent damage to the device. These are stress rating only; functional operation beyond the "Operation Conditions" is not recommended and extended exposure beyond the "Operation Conditions" may affect device reliability.

## ELECTRICAL PERFORMANCE CHARACTERISTICS

(T<sub>C</sub> = -55°C TO +125°C, +V<sub>CC</sub> = +5.0VDC ±5% -- UNLESS OTHERWISE SPECIFIED )

Parameter	Symbol	Condition	Min	Max	Unit
Source Current 1-5	I <sub>O</sub>	0 ≤ V <sub>IN</sub> ≤ 3.1V, V <sub>EN</sub> = V <sub>ENH</sub>	78	82	μA
	I <sub>OFF</sub>	0 ≤ V <sub>IN</sub> ≤ 3.1V, V <sub>EN</sub> = V <sub>ENL</sub>	-	150	nA
Comparator In Voltage <sup>1/</sup>	V <sub>IN</sub>	I <sub>OUT</sub> = 80μA	0	3.1	V
Comparator Ref In Voltage <sup>1/</sup>	V <sub>REF</sub>		-	3.1	V
Comparator Ref In Current	I <sub>REF</sub>		-	1200	nA
Enable Input Voltage Low	V <sub>ENL</sub>		-	0.8	V
Enable Input Voltage High	V <sub>ENH</sub>		2.4	-	V
Comparator Hysteresis <sup>1/</sup>	-		-	30	mV
Output Voltage Low 1-5	V <sub>OL</sub>	I <sub>SINK</sub> ≤ 2.0mA	-	0.4	V
Output Voltage High 1-5	V <sub>OH</sub>		4.4	-	V
Input Open Circuit Voltage	V <sub>INOC</sub>		4.0	4.6	V
Band Gap Regulator Output Voltage	V <sub>BG</sub>	T <sub>A</sub> = 25°C	1.990	2.010	V
		T <sub>C</sub> = -55°C, +125°C	1.980	2.020	V
Band Gap Load Regulation	$\frac{\Delta V_{BG}}{\Delta I_{BG}}$	I <sub>BG</sub> = 0 to 2mA	-5	5	mV
Internal Output Pull-Up Resistor	R <sub>INT</sub>		8	12	KΩ
Comparator Pulse Delay Low to High	t <sub>DLH</sub>	C <sub>L</sub> = 37pF, V <sub>EN</sub> = V <sub>ENH</sub> , V <sub>REF</sub> = 1V, V <sub>IN</sub> = 2V, I <sub>SINK</sub> = 0, See Figure 2 <sup>2/</sup>	0.2	10	μS
Comparator Pulse Delay High to Low	t <sub>DHL</sub>		80	150	nS
Enable Delay to Vout	t <sub>EDVLH</sub>	C <sub>L</sub> = 37pF, V <sub>IN</sub> = 0V, V <sub>REF</sub> = 1V, I <sub>SINK</sub> = 0, See Figure 2 <sup>2/</sup>	100	1500	nS
	t <sub>EDVHL</sub>		500	3000	nS
Enable Delay to Iout	t <sub>EDILH</sub>	C <sub>L</sub> = 68pF, I <sub>SINK</sub> = 0, See Figure 2 <sup>2/</sup>	100	250	nS
	t <sub>EDIHL</sub>		100	250	nS
Supply current Disabled Enabled	I <sub>CCD</sub> I <sub>CCE</sub>		-	4.0	mA
			-	7.0	mA

Notes:

<sup>1/</sup> Guaranteed by design, but not tested.

<sup>2/</sup> Test fixture node capacitance plus 10pF scope capacitance.

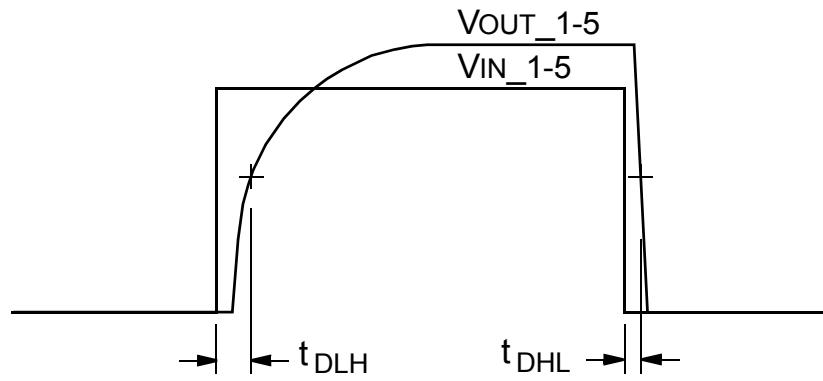

Comparator Pulse Delay

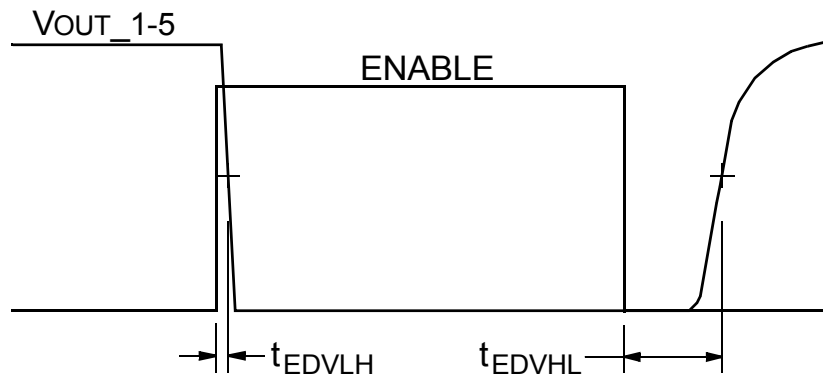

ENABLE Delay to VOUT\_1-5

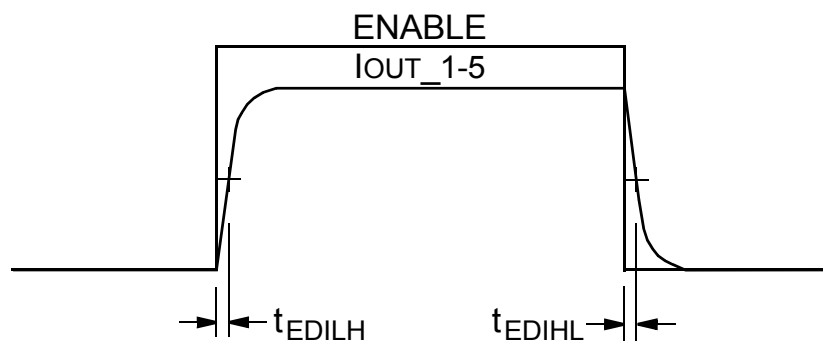

ENABLE Delay to IOUT\_1-5

**FIGURE 2 – TIMING DIAGRAMS**

One primary application for the Aeroflex PCS5035, as shown in Figure 3 below, would be to monitor the temperature of different electronic bay areas in a Satellite, and report when any bay area has exceeded a maximum temperature limit.

Thermistors with defined temperature characteristics are used as the sensors, and by providing a constant stable current to the external Thermistor (Temp T1 to Temp T5), an accurate analog voltage of a specified temperature trip point can be established. The comparator voltage reference input can be tailored to set the trip point for the characteristic of the particular thermistor sensor used. The on-board precision 2V reference can be used directly for voltages of 2 volts or less, or can be scaled with an external operational amplifier to provide a voltage between 2 volts and the maximum input of 3.1V. Various temperature trip points could be accomplished by using thermistors with different temperature characteristics.

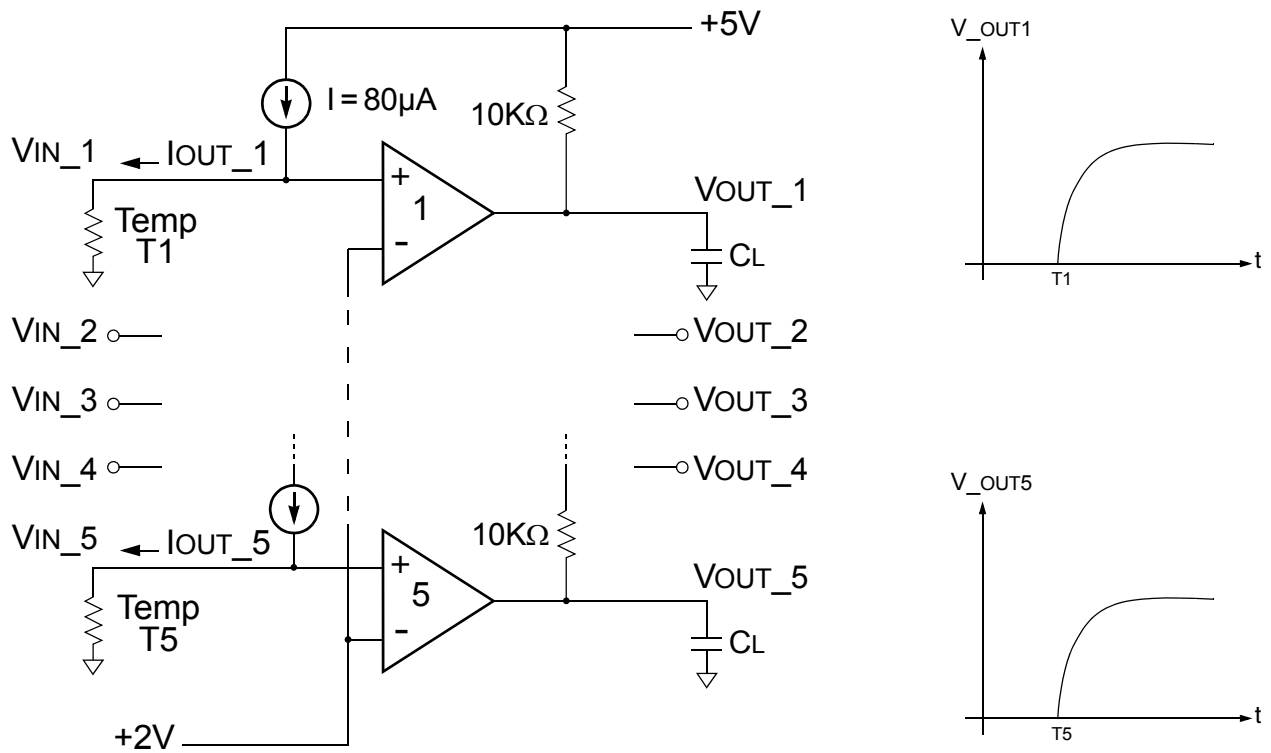

**FIGURE 3 – Typical Temperature Sensing Application**

Another application for the Aeroflex PCS5035 device is to provide precision excitation sources and threshold detection for five temperature sensors. The temperature sensors are typically thermistors, but can also be RTDs or silicon diodes. A typical application is shown below. The PCS5035 contains five independent current sources, internally trimmed to 80 uA ( $\pm 2\mu\text{A}$ ) each. The PCS5035 also contains an internal precision bandgap voltage reference, set to 2.000 Volts ( $\pm 0.010\text{Volts}$ ). Five complete temperature monitor circuits can be obtained by connecting external thermistors as shown below. The table below provides a selection of GE Sensing thermistors that may be used to provide six different threshold temperatures. These devices have negative temperature coefficients, ranging from  $-3.83\%/^{\circ}\text{C}$  to  $-4.84\%/^{\circ}\text{C}$ . In each case, the threshold is reached when the temperature of the thermistor is exactly 12.5KW. If the temperature is below the threshold, the sensor voltage is greater than 2.000 Volts and the comparator output is high; when the temperature exceeds the threshold, the sensor voltage drops below the 2.000 Volt reference and the comparator output goes low. The comparator output configurations are open-collector, with internal 10KW pullup resistors. This allows the comparator outputs to be wire-ORed.

To set the thresholds at other temperatures, several options are available: Other thermistor types may be selected; shunt resistors may be used to adjust the sensor response; an external reference voltage may be used.

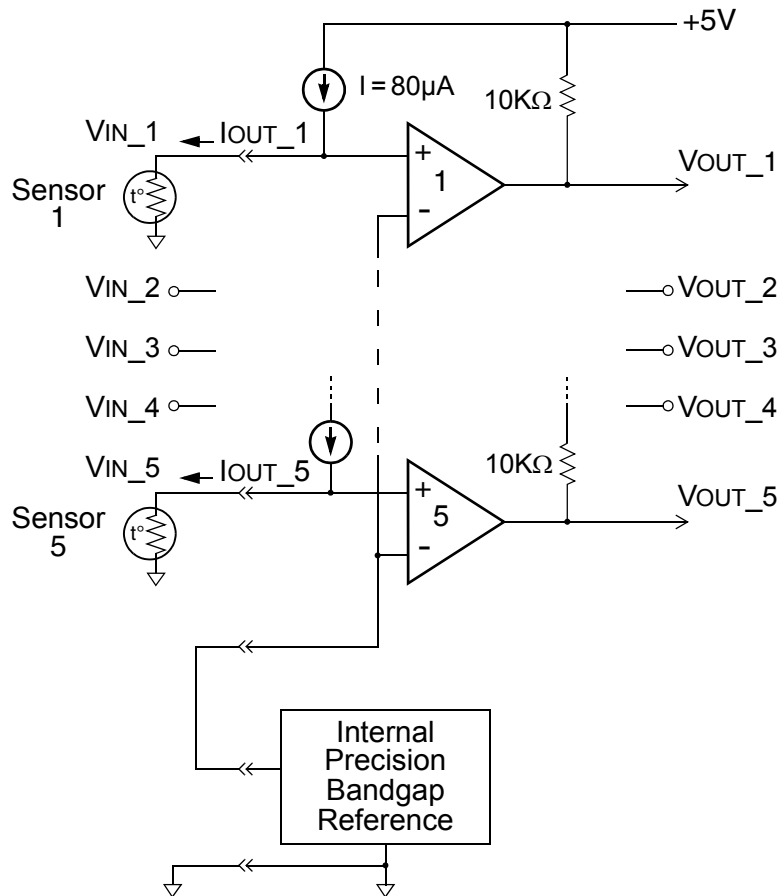

### Temperature Threshold Monitor with Internal Bandgap Reference Voltage

GE Sensing Thermistor Type	R (ohms) at 25°C	Temperature at 2.00V Threshold
RL0503-1248-73-MS	2K	- 17°C
RL0503-2890-95-MS	5K	+ 5°C
RL0503-5820-97-MS	10K	+ 20°C
RL0503-17.56K-96-MS	30K	+ 47°C
RL0503-27.53K-120-MS	50K	+ 56°C
RL0503-55.36K-122-MS	100K	+72°C

### Thermistor Types vs. Temperature Thresholds

When more "Temperature Sensing" inputs are needed two PCS5035 hybrids can be used as shown below in Figure 4.

The outputs of the two PCS5035 hybrids can be wired together to produce a wired "OR" function. Each bank of 5 inputs can then be separately controlled by its associated Enable input.

One application of this multiple input arrangement could be circuit board temperature monitoring using the temperature characteristics of a PN (diode) junction. With a constant current to the diode sensor the diode voltage can be a calibrated function of temperature. Diodes can be placed on or near vital electronic components to monitor their case temperatures so that they can be shutdown before a catastrophic temperature failure occurs.

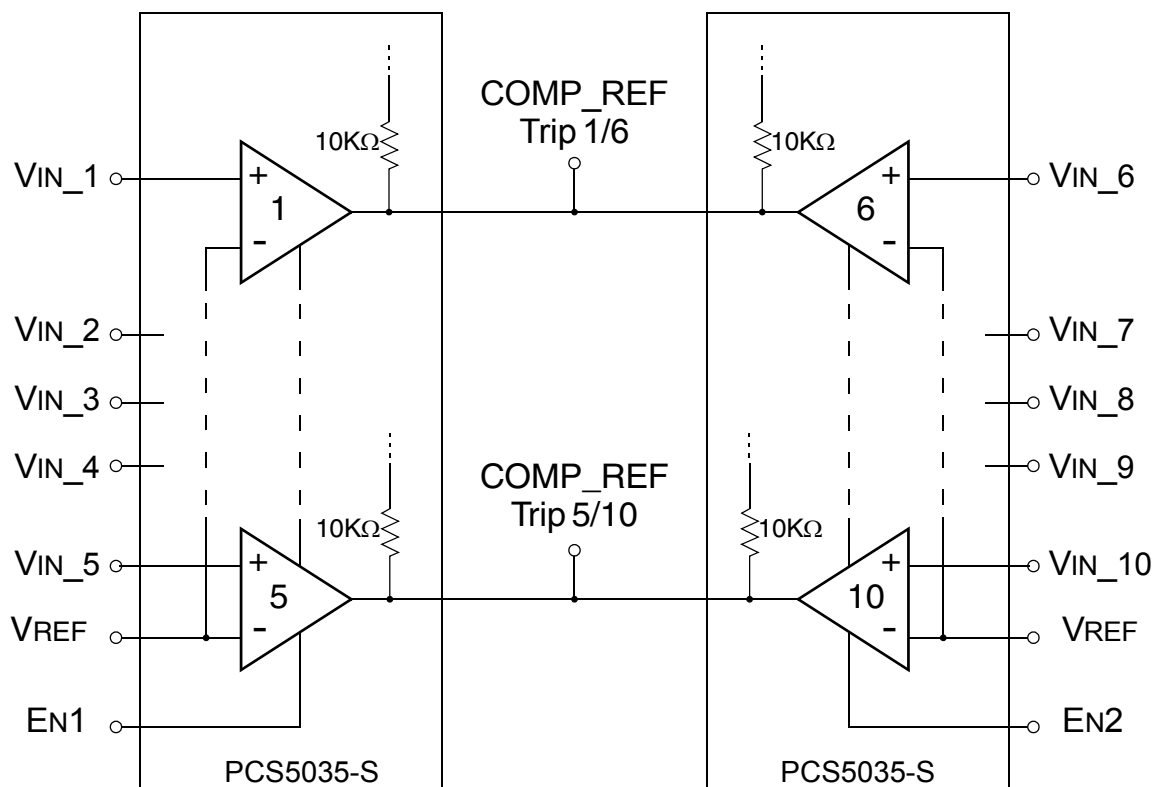

**FIGURE 4 – Wired "OR" Application**

## SIGNAL DESCRIPTION

Pin #	Signal Names	Description
1, 18	VCC	+5VDC $\pm$ 5%
2 - 6	IOUT/VIN_1 thru IOUT/VIN_5	Current Source Outputs / Comparator Inputs 1 thru 5
8	ENABLE	Turns all Current/Comparators "ON" or "OFF"
9, 10	GND	Logic and Power Return.
17 - 13	VOUT_1 thru VOUT_5	Voltage Outputs corresponding to Current source outputs 1 thru 5, includes 10K pull-ups
11	BG Reg OUT	Band Gap Regulator Precision Output 2.0Vdc
7	CASE_GND	Case Ground
12	COMPREF	External voltage to all 5 comparator inputs

## PIN # vs FUNCTION TABLE

Pin #	Function	Pin #	Function
1	Vcc	10	GND
2	IOUT/VIN_1	11	BG Reg OUT
3	IOUT/VIN_2	12	COMPREF
4	IOUT/VIN_3	13	VOUT_5
5	IOUT/VIN_4	14	VOUT_4
6	IOUT/VIN_5	15	VOUT_3
7	CASE_GND	16	VOUT_2
8	ENABLE	17	VOUT_1
9	GND	18	Vcc



## ORDERING INFORMATION

Model	DLA SMD #	Screening	Package
PCS5035-7	-	Commercial Flow, +25°C testing only	18 lead Flat Package
PCS5035-S	-	Military Temperature, -55°C to +125°C Screened in accordance with the individual Test Methods of MIL-STD-883 for Space Applications.	
PCS5035-201-1S PCS5035-201-2S	5962-0923401KXC 5962-0923401KXA	In accordance with DLA SMD	

## PACKAGE CONFIGURATION OUTLINE

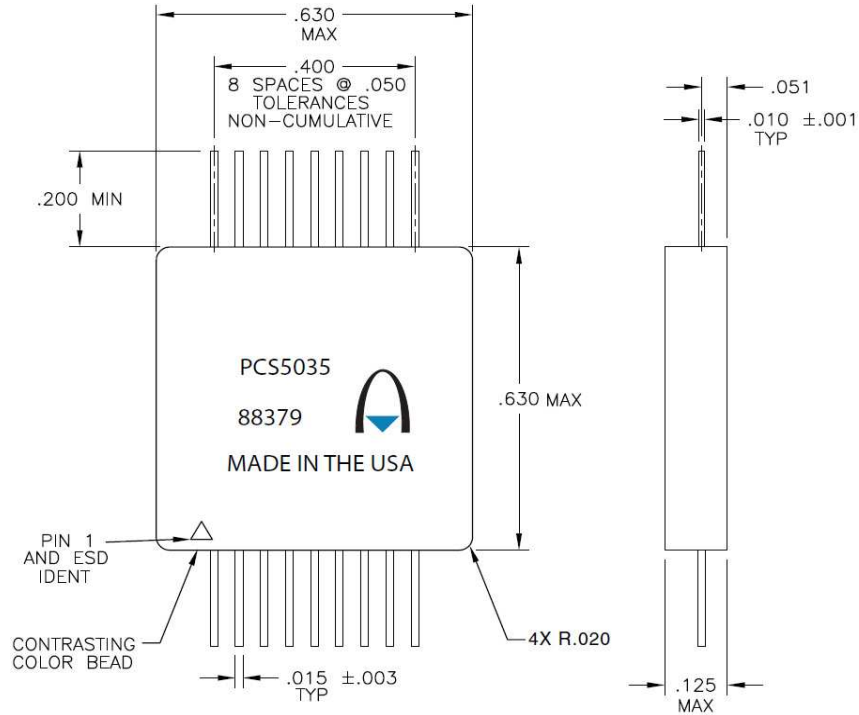

### EXPORT CONTROL:

*This product is controlled for export under the International Traffic in Arms Regulations (ITAR). A license from the U.S. Department of State is required prior to the export of this product from the United States.*

### EXPORT WARNING:

*Aeroflex's military and space products are controlled for export under the International Traffic in Arms Regulations (ITAR) and may not be sold or proposed or offered for sale to certain countries. (See ITAR 126.1 for complete information.)*

**PLAINVIEW, NEW YORK**  
Toll Free: 800-THE-1553  
Fax: 516-694-6715

**INTERNATIONAL**  
Tel: 805-778-9229  
Fax: 805-778-1980

**NORTHEAST**  
Tel: 603-888-3975  
Fax: 603-888-4585

**SE AND MID-ATLANTIC**  
Tel: 321-951-4164  
Fax: 321-951-4254

**WEST COAST**  
Tel: 949-362-2260  
Fax: 949-362-2266

**CENTRAL**  
Tel: 719-594-8017  
Fax: 719-594-8468

[www.aeroflex.com](http://www.aeroflex.com)    [info-ams@aeroflex.com](mailto:info-ams@aeroflex.com)



Aeroflex Microelectronic Solutions reserves the right to change at any time without notice the specifications, design, function, or form of its products described herein. All parameters must be validated for each customer's application by engineering. No liability is assumed as a result of use of this product. No patent licenses are implied.



Our passion for performance is defined by three attributes represented by these three icons: solution-minded, performance-driven and customer-focused