

SERIES ANT, ANR RESISTORS & TERMINATIONS

RoHS
Compliant

High Power, Aluminum Nitride, Thin Film, Drop-in – 10-600 Watts, DC-4 GHz



GENERAL INFORMATION

These high power devices are designed to dissipate power in RF circuits when mounted to an appropriate heat sink. The terminations provide a low VSWR under maximum power conditions. The resistor configurations are typically used in "Wilkinson" type power divider networks, or to terminate 3 dB stripline or microstrip hybrids. Aluminum nitride is used for those applications where the use and disposal of beryllium oxide is a concern.

NOTES

1. Input power ratings are based on flange temperature of 100° C maximum.
2. 50 and 100 Ohms standard. Other values from 10-500 Ohms available on special order. Contact factory for details. Standard tolerance $\pm 5\%$. Specify resistance value when ordering.
3. VSWR applies to termination style only.

AVERAGE POWER DERATING CURVE

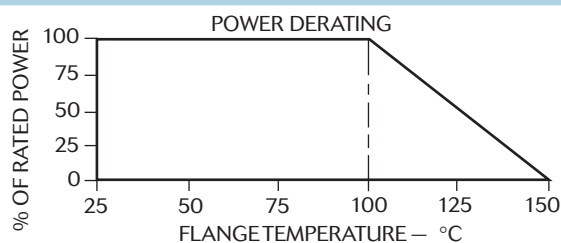





GENERAL SPECIFICATIONS

Resistive Element	Thin Film
Substrate	Aluminum Nitride
Cover	Alumina Ceramic
Mounting Flange	Copper, Nickel Plated per QQ-N-290
Tab	Beryllium Copper, Gold Plated per MIL-G-4520 4

PERFORMANCE SPECIFICATIONS

Model	Frequency Range	Input Power (Watts Avg.)	VSWR (Typical) (Note 3)	Capacitance (pF) (Typ.)	Figure No.
ANT & ANR 300-10	DC-4.0 GHz	10	1.25:1	1.0	1
ANT & ANR 515-40	DC-2.5 GHz	40	1.15:1	1.0	2
ANT & ANR 515-80	DC-1.0 GHz	80	1.25:1	1.6	2
ANT & ANR 800-100	DC-2.0 GHz	100	1.25:1	1.4	3
ANT & ANR 870-150	DC-2.0 GHz	150	1.25:1	4.5	4
ANT & ANR 975-200	DC-1.0 GHz	200	1.25:1	4.5	5
ANT & ANR 1250-400	DC-500 MHz	400	1.50:1	7.0	6
ANT & ANR 1900-600	DC-500 MHz	600	1.50:1	15.0	7

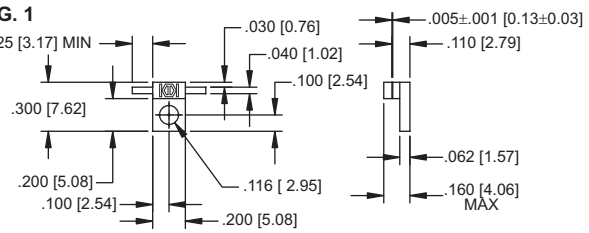

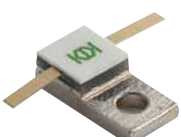
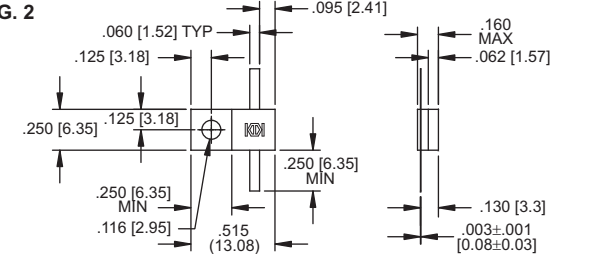
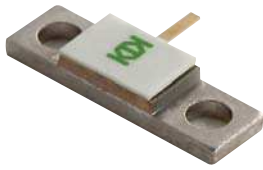
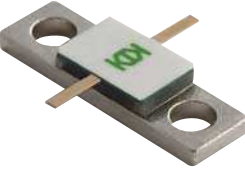
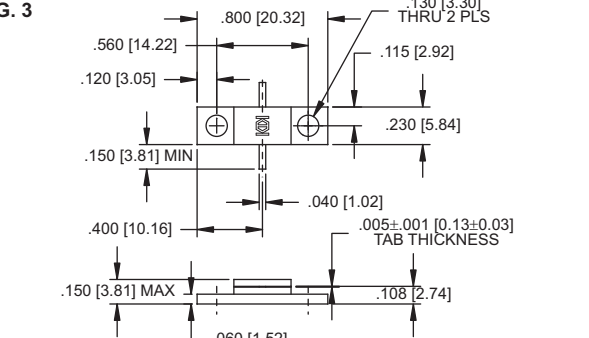



PHYSICAL DIMENSIONS

TERMINATIONS (ANT) SERIES	RESISTORS (ANR) SERIES	FIGURES
ANT 300-10 — 10 WATTS Flange Mounted 	ANR 300-10 — 10 WATTS Flange Mounted 	FIG. 1 
ANT 515-40 — 40 WATTS ANT 515-80 — 80 WATTS Flange Mounted 	ANR 515-40 — 40 WATTS ANR 515-80 — 80 WATTS Flange Mounted 	FIG. 2 
ANT 800-100 — 100 WATTS Flange Mounted 	ANR 800-100 — 100 WATTS Flange Mounted 	FIG. 3 

KEY: Inches [Millimeters] .XX \pm .03 .XXX \pm .010 LX \pm 0.8 XX \pm 0.25]

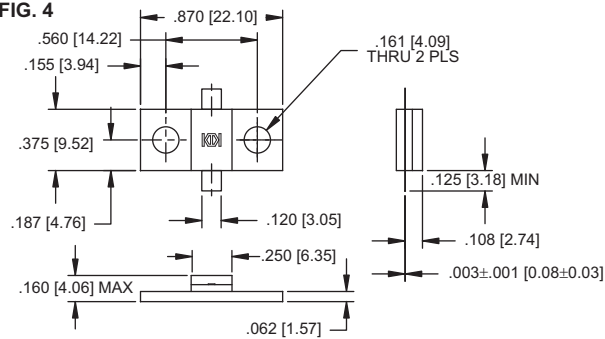
SERIES ANT, ANR RESISTORS & TERMINATIONS

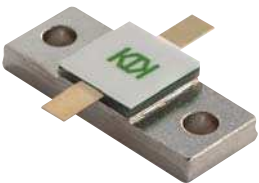
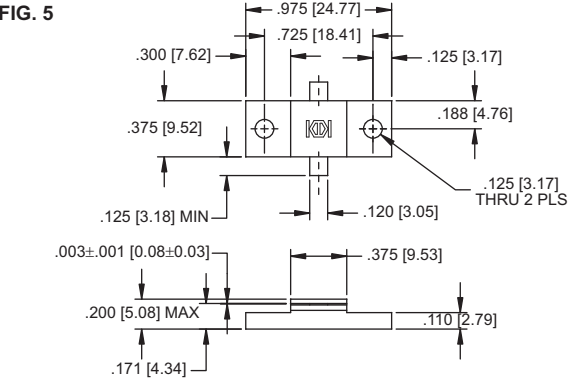
PHYSICAL DIMENSIONS

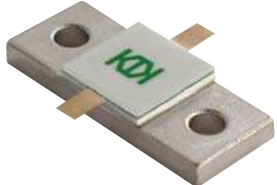
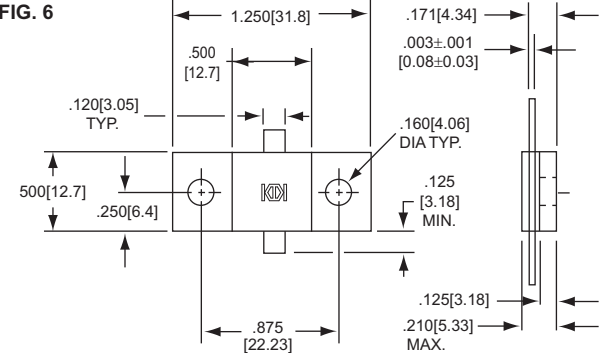
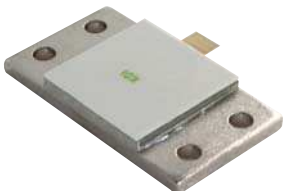
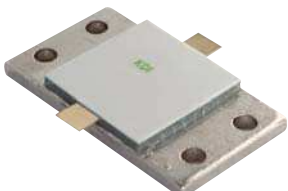
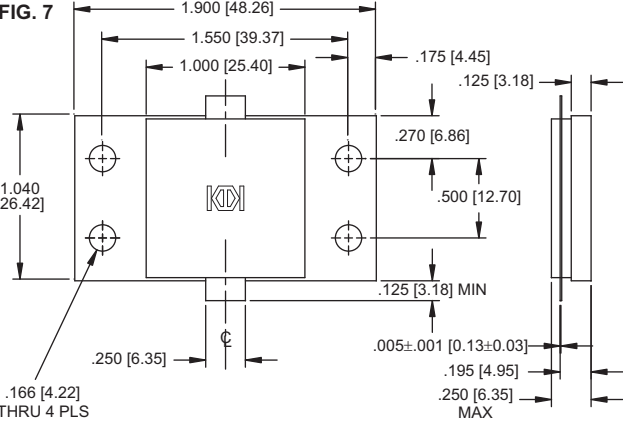
TERMINATIONS (ANT) SERIES	RESISTORS (ANR) SERIES	FIGURES
ANT 870-150 — 150 WATTS Flange Mounted 	ANR 870-150 — 150 WATTS Flange Mounted 	FIG. 4 
ANT 975-200 — 200 WATTS Flange Mounted 	ANR 975-200 — 200 WATTS Flange Mounted 	FIG. 5 
ANT 1250-400 — 400 WATTS Flange Mounted 	ANR 1250-400 — 400 WATTS Flange Mounted 	FIG. 6 
ANT 1900-600 — 600 WATTS Flange Mounted 	ANR 1900-600 — 600 WATTS Flange Mounted 	FIG. 7 

KEY: Inches [Millimeters] .XX ±.03 .XXX ±.010 [X ±0.8 .XX ±0.25]