

# UT200SpWPHY01 SpaceWire Physical Layer Transceiver



## FEATURES

- ❑ 2-bit Serializer/Deserializer (SerDes) functionality
- ❑ LVDS physical layer
- ❑ Data rates to 200 Mbits/sec
- ❑ Data/Strobe transmit skew <500pS
- ❑ 3.3V power supply
- ❑ Cold spare on LVDS pins
- ❑ Radiation-hardened design; total dose irradiation testing to MIL-STD-883 Method 1019
  - Total-dose: 100 krad(Si)
  - Latchup immune (LET > 109 MeV-cm<sup>2</sup>/mg)
- ❑ ESD rating Class 1
- ❑ Packaged in a 28-pin flatpack
- ❑ Standard Microcircuit Drawing 5962-06232
  - QML Q and V compliant part

## INTRODUCTION

Aeroflex Colorado Springs' UT200SpWPHY01 Physical Layer Transceiver (PHY) is designed to handle the critical timing issues associated with the SpaceWire Data/Strobe Encoding scheme.

The receiver operates on both edges of the recovered RxClk and provides data on the digital outputs in bit pairs. The transmitter operation is the reverse of the receiver. Bit pairs of data and strobe are written into the device on the WrClk signal and the PHY serializes data and strobe onto the LVDS bus using the TxClk signal. The advantages of this SerDes functionality is the interfacing FPGA or ASIC can run at reduced clock rate with high-speed clock not requiring a stringent phase relationship.

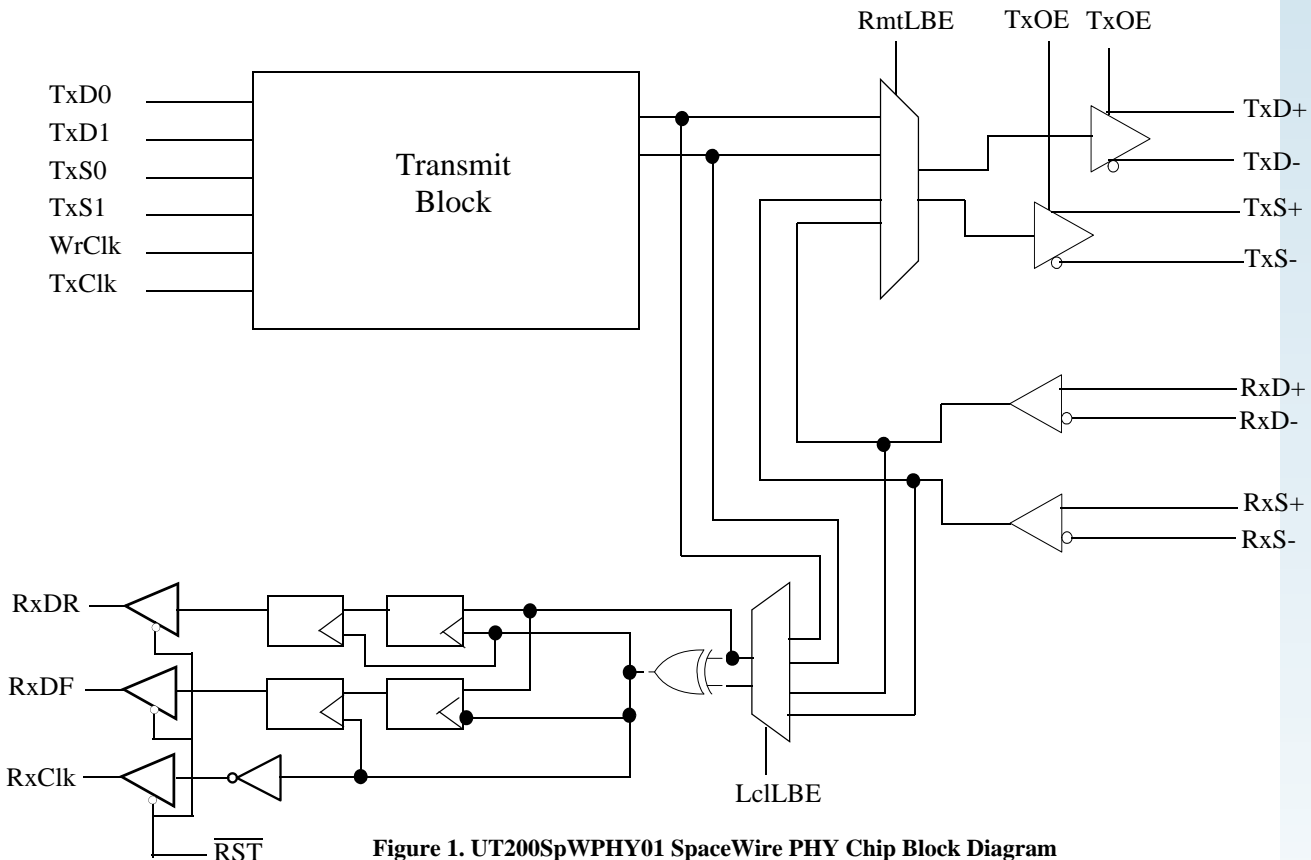


Figure 1. UT200SpWPHY01 SpaceWire PHY Chip Block Diagram

## APPLICATIONS INFORMATION

Aeroflex Colorado Springs' UT200SpWPHY01 SpaceWire Physical Layer Transceiver is designed to maximize the speed of SpaceWire links implemented in Field Programmable Gate Arrays. The UT200SpWPHY01 is designed to handle the critical timing issues associated with the SpaceWire data/strobe encoding scheme.

### Receiver Fail-Safe

The UT200SpWPHY01 SpaceWire Physical Layer Transceiver is a high gain, high speed device that amplifies a small differential signal (20mV) to TTL logic levels. Due to the high gain and tight threshold of the receiver, care should be taken to prevent noise from appearing as a valid signal.

The receiver's internal fail-safe circuitry is designed to source/sink a small amount of current, providing fail-safe protection (a stable known state of HIGH output voltage) for floating, terminated or shorted receiver inputs.

1. **Open Input Pins.** If an application requires an unused channel, the inputs should be left OPEN. Do not tie unused receiver inputs to ground or any other voltages. The input is biased by internal high value pull up and pull down resistors to set the output to a HIGH state. This internal circuitry will guarantee a HIGH, stable output state for open inputs.

2. **Terminated Input.** If the driver is disconnected (cable unplugged), or if the driver is in a three-state or power-off condition, the receiver output will again be in a HIGH state, even with the end of cable 100 $\Omega$  termination resistor across the input pins. The unplugged cable can become a floating antenna which can pick up noise. If the cable picks up more than 10mV of differential noise, the receiver may see the noise as a valid signal and switch. To insure that any noise is seen as common-mode and not differential, a balanced interconnect should be used. Twisted pair cable offers better balance than flat ribbon cable.

**Shorted Inputs.** If a fault condition occurs that shorts the receiver inputs together, thus resulting in a 0V differential input voltage, the receiver output remains in a HIGH state. Shorted input fail-safe is not supported across the common-mode range of the device ( $V_{SS}$  to 2.4V). It is only supported with inputs shorted and no external common-mode voltage applied.

**Table 1: SpaceWire Physical Layer Transceiver Device Operation Truth Table**

| TxOE | $\overline{\text{RST}}$ | LclLBE | RmtLBE | Tx Outputs     | Rx Outputs     |
|------|-------------------------|--------|--------|----------------|----------------|
| 0    | 0                       | X      | X      | Hi-Z           | Hi-Z           |
| 1    | 1                       | 0      | 0      | CMOS Tx Inputs | LVDS Rx Inputs |
| 0    | 1                       | 0      | X      | Hi-Z           | LVDS Rx Inputs |
| 0    | 1                       | 1      | X      | Hi-Z           | CMOS Tx Inputs |
| 1    | 0                       | X      | 0      | 0              | Hi-Z           |
| 1    | 0                       | X      | 1      | LVDS Rx Inputs | Hi-Z           |
| 1    | 1                       | 0      | 1      | LVDS Rx Inputs | LVDS Rx Inputs |
| 1    | 1                       | 1      | 0      | CMOS Tx Inputs | CMOS Tx Inputs |
| 1    | 1                       | 1      | 1      | LVDS Rx Inputs | CMOS Tx Inputs |

## RADIATION

| Parameter   | Limit              | Units                   |
|---|--------------------|-------------------------|
| Total Ionizing Dose (TID)                                 | >3E5<br>and<br>1E6 | rads(Si)                |
| Single Event Latchup (SEL) <sup>1, 2</sup>                | >109               | MeV-cm <sup>2</sup> /mg |
| SEU Saturated Cross-Section ( $\sigma_{\text{sat}}$ )     | 1.0E-8             | cm <sup>2</sup> /device |
| Onset Single Event Upset (SEU) LET Threshold <sup>3</sup> | 109                | MeV-cm <sup>2</sup> /mg |
| Neutron Fluence   | 1.0E14             | n/cm <sup>2</sup>       |
| Dose Rate Upset   | TBD                | rads(Si)/sec            |
| Dose Rate Survivability                                   | TBD                | rads(Si)/sec            |

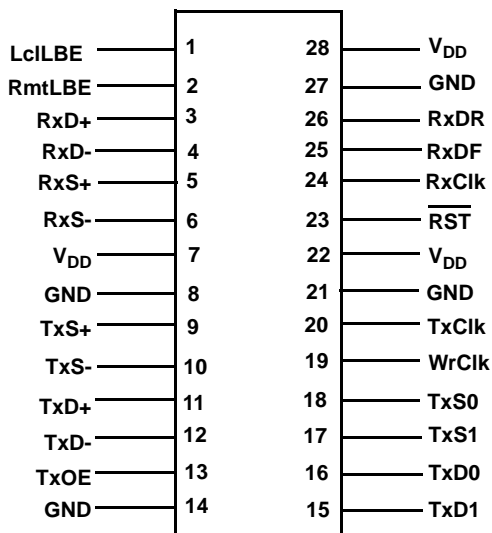
### Notes:

1. The UT200SpW02 are latchup immune to particle LETs >109 MeV-cm<sup>2</sup>/mg.
2. Worst case temperature and voltage of T<sub>C</sub> = +125°C, V<sub>DD</sub> = 3.6V, V<sub>DD</sub>Q1/Q3/Q4 = 3.6V for SEL.
3. Worst case temperature and voltage of T<sub>C</sub> = +25°C, V<sub>DD</sub> = 3.0V, V<sub>DD</sub>Q1/Q3/Q4 = 3.0V for SEU.
4. Adams 90% worst case particle environment, Geosynchronous orbit, 100mils of Aluminum shielding.

| 28-pin Flatpack Pin Description |            |                            |   |
|---------------------------------|------------|----------------------------|---|
| Pin Name                        | Pin Number | Pin Type                   | Description   |
| LclLBE                          | 1          | LVC MOS Input <sup>1</sup> | <b>Local Loopback Enable</b><br>0: No loopback, received data comes from LVDS Rx inputs (RxD+, ...)<br>1: Local loopback, received data comes from LVC MOS Tx inputs (Tx D0, ...)                               |
| RmtLBE                          | 2          | LVC MOS Input <sup>1</sup> | <b>Remote Loopback Enable</b><br>0: No loopback, Transmit LVDS data comes from the LVC MOS Tx inputs (Tx D0, ...)<br>1. Remote Loopback, Transmit LVDS data comes from LVDS Rx inputs.                          |
| RxD+                            | 3          | LVDS Input                 | LVDS Rx differential positive Data input  |
| RxD-                            | 4          | LVDS Input                 | LVDS Rx differential negative Data input  |
| RxS+                            | 5          | LVDS Input                 | LVDS Rx differential positive Strobe input  |
| RxS-                            | 6          | LVDS Input                 | LVDS Rx differential negative Strobe input  |
| V <sub>DD</sub>                 | 7, 22, 28  |                            | VDD 3.3V power supply   |
| GND                             | 8,14,21,27 |                            | V <sub>ss</sub> 0V  |
| TxS+                            | 9          | LVDS Output                | LVDS Tx differential positive Strobe output   |
| TxS-                            | 10         | LVDS Output                | LVDS Tx differential negative Strobe output   |
| TxD+                            | 11         | LVDS Output                | LVDS Tx differential positive Data output   |
| TxD-                            | 12         | LVDS Output                | LVDS Tx differential negative Data output   |
| TxOE                            | 13         | LVC MOS Input <sup>1</sup> | TxOE=High: Enables LVDS transmit<br>TxOE=Low: Tri-states LVDS transmit  |
| RxDR                            | 26         | LVC MOS Output             | Receiver rising edge (even) bit output (See Figure 7)   |
| RxDF                            | 25         | LVC MOS Output             | Receiver falling edge (odd) bit output (See Figure 7)   |
| RxCk                            | 24         | LVC MOS Output             | Receiver clock output   |
| $\overline{\text{RST}}$         | 23         | LVC MOS Input <sup>1</sup> | $\overline{\text{RST}}$ must remain low for 3 clock cycles before transitioning high, and must transition high 3 clock cycles before valid data.  |
| TxCk                            | 20         | LVC MOS Input <sup>1</sup> | Clock input to transmitter used to clock LVDS output. Any phase relationship is allowed between TxClk & WrClk but both must come from the same clock source and TxClk must be twice the frequency of the WrClk. |
| WrClk                           | 19         | LVC MOS Input <sup>1</sup> | Transmitter input data Clock used to clock CMOS input to transmitter. Any phase relationship is allowed between TxClk & WrClk but both must come from the same clock source and WrClk must 1/2 of TxClk.        |
| TxS0                            | 18         | LVC MOS Input              | First (even) bit of 2bit parallel strobe input to transmitter   |
| TxS1                            | 17         | LVC MOS Input              | Second (odd) bit of 2bit parallel strobe input to transmitter   |
| TxD0                            | 16         | LVC MOS Input              | First, even bit of 2bit parallel data input to transmitter  |
| TxD1                            | 15         | LVC MOS Input              | Second, odd bit of 2bit parallel data input to transmitter  |

Note 1. LVTTTL compatible

## PIN CONFIGURATION



## ABSOLUTE MAXIMUM RATINGS<sup>1</sup>

(Referenced to V<sub>SS</sub>)

| SYMBOL           | PARAMETER  | LIMITS                           |
|------------------|--|----------------------------------|
| V <sub>DD</sub>  | DC supply voltage                                      | -0.3 to 4.0V                     |
| V <sub>I/O</sub> | Voltage on any pin during operation                    | -0.3 to (V <sub>DD</sub> + 0.3V) |
|                  | Voltage on any LVDS pin during cold spare <sup>2</sup> | -3 to 4.0V                       |
| T <sub>STG</sub> | Storage temperature                                    | -65 to +150°C                    |
| P <sub>D</sub>   | Maximum power dissipation                              | 432 mW                           |
| Θ <sub>JC</sub>  | Thermal resistance, junction-to-case <sup>3</sup>      | 10°C/W                           |
| I <sub>I</sub>   | DC input current                                       | ±10mA                            |

### Notes:

- Stresses outside the listed absolute maximum ratings may cause permanent damage to the device. This is a stress rating only, and functional operation of the device at these or any other conditions beyond limits indicated in the operational sections of this specification is not recommended. Exposure to absolute maximum rating conditions for extended periods may affect device reliability and performance.
- LVCMOS pins are not cold spare.
- Test per MIL-STD-883, Method 1012.

## RECOMMENDED OPERATING CONDITIONS

| SYMBOL          | PARAMETER         | LIMITS                |
|-----------------|-------------------|-----------------------|
| V <sub>DD</sub> | DC Supply Voltage | 3.0V to 3.6V          |
| V <sub>IN</sub> | DC input voltage  | 0V to V <sub>DD</sub> |

**DC ELECTRICAL CHARACTERISTICS<sup>1</sup>**  
**( $V_{DD} = 3.3V \pm 0.3V$ ;  $-55^{\circ}C < T_C < +125^{\circ}C$ )**

| SYMBOL          | PARAMETER  | CONDITION   | MIN   | MAX   | UNIT    |
|-----------------|--|---|-------|-------|---------|
| $V_{IH}$        | High-level input voltage (CMOS)                                  |   | 2.0   |       | V       |
| $V_{IL}$        | Low-level input voltage (CMOS)                                   |   |       | 0.8   | V       |
| $V_{OL}$        | Low-level output voltage (LVCMOS)                                | $I_{OL} = 12mA$   |       | 0.4   | V       |
| $V_{OH}$        | High-level output voltage (LVCMOS)                               | $I_{OH} = -12mA$  | 2.4   |       | V       |
| $I_{INLVDS}$    | Input leakage current  | $V_{IN} = V_{DD}$ or GND, $V_{DD} = 3.6V$   | -20   | +20   | $\mu A$ |
| $I_{INCMOS}$    | Input leakage current  | $V_{IN} = V_{DD}$ or GND, $V_{DD} = 3.6V$   | -10   | +10   | $\mu A$ |
| $I_{CS}$        | Cold Spare Leakage Current                                       | $V_{IN}=3.6V$ , $V_{DD} = V_{SS} = 0V$  | -20   | +20   | $\mu A$ |
| $V_{TH}$        | Differential Input High Threshold                                | $V_{CM} = +1.2V$  |       | +100  | mV      |
| $V_{TL}$        | Differential Input Low Threshold                                 | $V_{CM} = +1.2V$  | -100  |       | mV      |
| $V_{OD}$        | Differential Output Voltage                                      | $R_L = 100\Omega$   | 250   | 400   | mV      |
| $\Delta V_{OD}$ | Change in Magnitude of $V_{OD}$ for Complementary Output States  | $R_L = 100\Omega$   |       | 35    | mV      |
| $V_{OS}$        | Offset Voltage   | $R_L = 100\Omega$ , $(V_{OS} = \frac{V_{OH} + V_{OL}}{2})$  | 1.125 | 1.450 | V       |
| $\Delta V_{OS}$ | Change in Magnitude of $V_{OS}$ for Complementary Output States  | $R_L = 100\Omega$   |       | 25    | mV      |
| $I_{OZ}$        | LVDS Output Three-State Current                                  | $TxOE = Gnd$<br>$V_{OUT} = 0V$ or $V_{DD}$ , $V_{DD} = 3.6V$  | -10   | +10   | $\mu A$ |
| $I_{CCL}$       | Loaded supply current, drivers enabled                           | $R_{TEST} = 50\Omega$ all channels, running in full duplex<br>$V_{IN} = V_{DD}$ or $V_{SS}$ (all inputs)<br>$C_L = 37pF$ , $F = 200MHz$ |       | 120   | mA      |
| $I_{CCZ}$       | Loaded supply current, drivers disabled                          | $D_{IN} = V_{DD}$ or $V_{SS}$<br>Clock and Data not toggling  |       | 10    | mA      |
| $I_{CCI}$       | Supply current, data toggling, clocks running, device in standby | Clock @ 200 Mhz, $TxOE = 0$<br>Data @ 200 Mbits/sec, $\overline{RST} = 0$   |       | 25    | mA      |
| $C_{IN}^2$      | LVCMOS input capacitance   | $f = 1MHz @ 0V$   |       | 7     | pF      |
| $C_{OUT}^2$     | LVCMOS output capacitance  | $f = 1MHz @ 0V$   |       | 15    | pF      |
| $C_{INLVDS}^2$  | LVDS input capacitance   | $f = 1MHz @ 0V$   |       | 6     | pF      |
| $C_{OUTLVDS}^2$ | LVDS output capacitance  | $f = 1MHz @ 0V$   |       | 7     | pF      |

**Notes:**

1. Current into device pins is defined as positive. Current out of device pins is defined as negative. All voltages are referenced to ground except differential voltages.
2. Capacitance is measured for initial qualification and when design changes may affect the input/output capacitance. Capacitance is measured between the designated terminal and  $V_{SS}$  at a frequency of 1MHz and a signal amplitude of 50mV maximum.
3.  $R_{TEST}$  is the tester load.  $R_L$  is the LVDS termination load.

## AC SWITCHING CHARACTERISTICS

( $V_{DD} = +3.3V \pm 0.3V$ ,  $T_A = -55\text{ }^\circ\text{C}$  to  $+125\text{ }^\circ\text{C}$ )

| SYMBOL          | PARAMETER   | MIN | MAX | UNIT           |
|-----------------|---|-----|-----|----------------|
| $t_{CDLH}$      | TxCk to differential Data output low to high prop delay $R_{TEST}=50$ , $C_L = 37\text{pF}$ (figure 2)  | 2   | 4   | ns             |
| $t_{CDHL}$      | TxCk to differential Data output high to low prop delay $R_{TEST}=50$ , $C_L = 37\text{pF}$ (figure 2)  | 2   | 4   | ns             |
| $t_{CSLH}$      | TxCk to differential Strobe output low to high prop delay $R_{TEST}=50$ , $C_L = 37\text{pF}$ (figure 2)  | 2   | 4   | ns             |
| $t_{CSHL}$      | TxCk to differential Strobe output high to low prop delay $R_{TEST}=50$ , $C_L = 37\text{pF}$ (figure 2)  | 2   | 4   | ns             |
| $t_{DCS}$       | Differential Channel Skew   |     | 0.4 | ns             |
| $t_{CCS}^1$     | Channel to Channel Skew   |     | 0.5 | ns             |
| $t_{TLH}^2$     | Rise time LVDS Driver (figure 2) $R_L=100$ , $C_L = 37\text{pF}$  |     | 1.5 | ns             |
| $t_{THL}^2$     | Fall time LVDS Driver (figure 2) $R_L=100$ , $C_L = 37\text{pF}$  |     | 1.5 | ns             |
| $t_{OEZH}$      | Output Enable Low to Data or Strobe High to Z (figure 3, 4) $R_{TEST} = 50$ , $C_L = 37\text{pF}$   |     | 5   | ns             |
| $t_{OELZ}$      | Output Enable Low to Data or Strobe Low to Z (figure 3, 4) $R_{TEST} = 50$ , $C_L = 37\text{pF}$  |     | 5.0 | ns             |
| $t_{OEZH}$      | Output Enable High to Data or Strobe Z to High (figure 3, 4) $R_{TEST} = 50$ , $C_L = 37\text{pF}$  |     | 5   | ns             |
| $t_{OEZL}$      | Output Enable High to Data or Strobe Z to Low (figure 3, 4) $R_{TEST} = 50$ , $C_L = 37\text{pF}$   |     | 5.0 | ns             |
| $t_{SETUP\ TX}$ | Minimum required setup of Data or Strobe with respect to WrClk (figure 6)   | 2   |     | ns             |
| $t_{HOLD\ TX}$  | Minimum required hold of Data or Strobe with respect to WrClk (figure 6)  | 0   |     | ns             |
| $t_{INRISE}^3$  | Maximum rise time into Data/Strobe inputs (0.8V to 2V)  |     | 14  | % of bit width |
| $t_{INFALL}^3$  | Maximum fall time into Data/Strobe inputs (0.8V to 2V)  |     | 14  | % of bit width |
| $t_{DRST}$      | Minimum number of full clock cycles (WrClk) between rising edge of $\overline{RST}$ and rising edge of first valid data or strobe (TxDO, TxD1, TxS0, TxS1) (figure 5) | 3   |     | WrClk cycles   |
| $t_{CRST}$      | Minimum number of full clock cycles (WrClk) that $\overline{RST}$ must remain low before $\overline{RST}$ can transition high (figure 5)                              | 3   |     | WrClk cycles   |
| $t_{CO}$        | Delay between RxClk falling and data edge (figure 7)  |     | 1   | ns             |
| $t_{RLZ}$       | Delay between $\overline{RST}$ going low and CMOS output tri-state (figure 7) $R_{TEST} = 50$ , $C_L = 37\text{pF}$   |     | 5   | ns             |
| $t_{RHV}$       | Delay between $\overline{RST}$ going high and CMOS output valid (figure 7) $R_{TEST} = 50$ , $C_L = 37\text{pF}$  |     | 5   | ns             |
| $t_{RISE}$      | CMOS 20-80% Receiver output rise time (figure 8) $C_L = 37\text{pF}$  |     | 1   | ns             |
| $t_{FALL}$      | CMOS 20-80% Receiver output fall time (figure 8) $C_L = 37\text{pF}$  |     | 1   | ns             |
| $t_S^3$         | LVDS Rx input data to strobe separation (figure 9)  | 2.5 |     | ns             |
| $TxCk_{PMIN}$   | Minimum Transmit Clock period   |     | 5   | ns             |
| $WrClk_{PMIN}$  | Minimum Write Clock period  |     | 10  | ns             |
| $t_{CPMIN}$     | Minimum High or Low Clock Pulse Width   | 2   |     | ns             |

### Notes:

1. Includes differential skew
2. Guaranteed by characterization
3. Specified as a design guidelines only, not tested.
4. 2.5 ns of separation requires a  $R_{XOUT}$  Load of  $\leq 10\text{pF}$

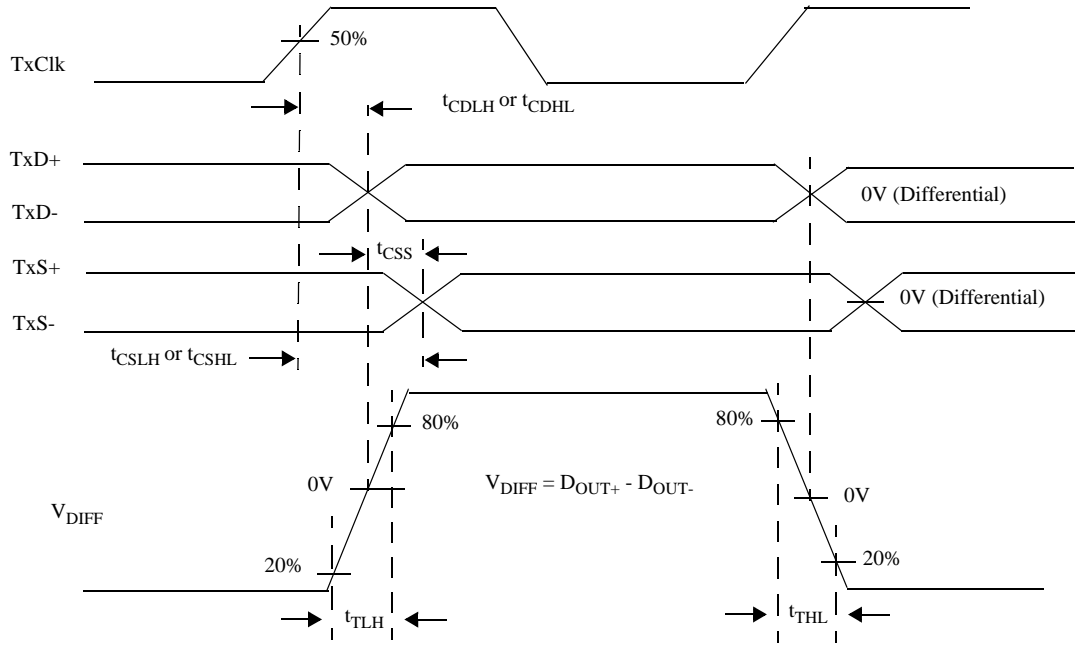


Figure 2. Driver Rise and Fall times and Channel Skew

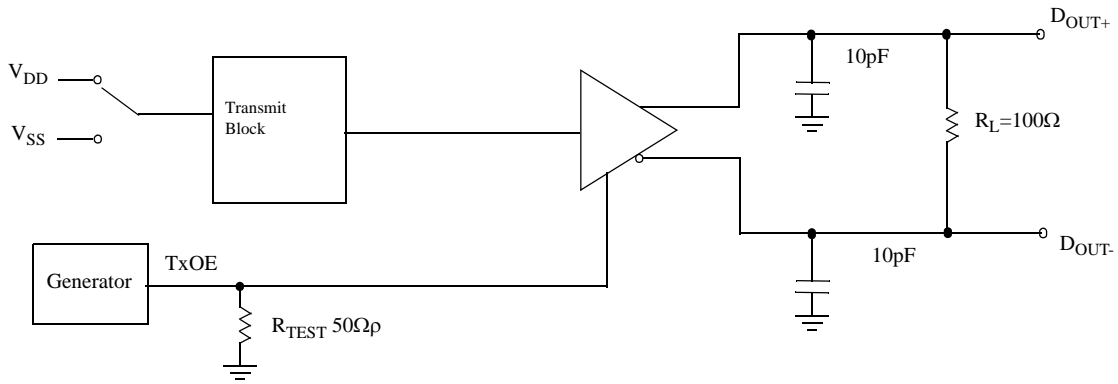
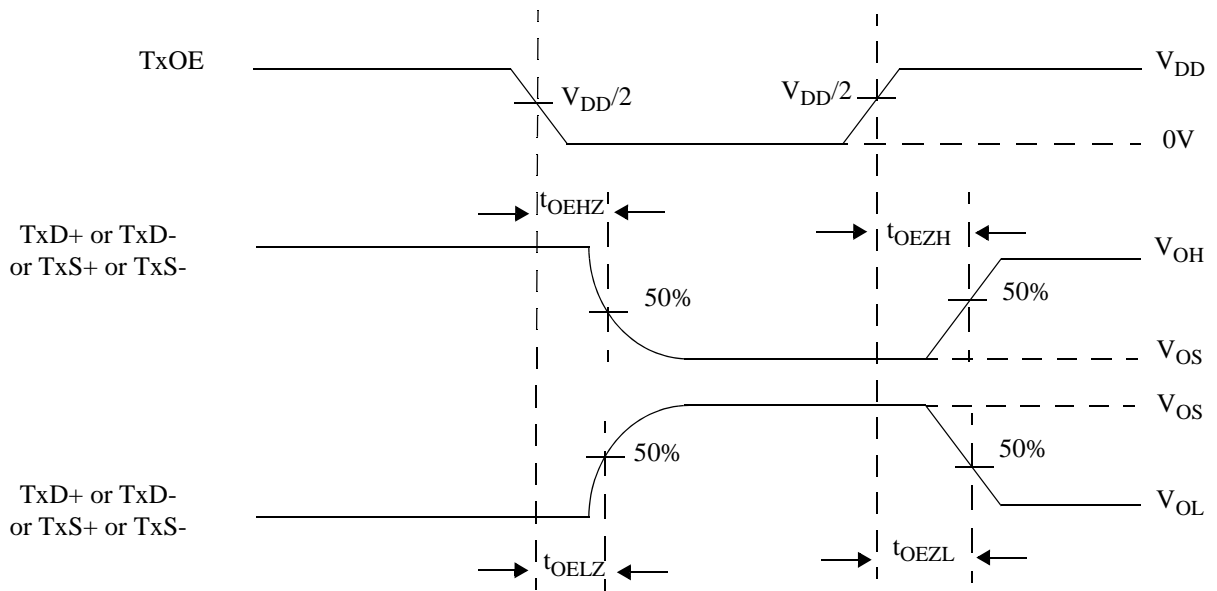
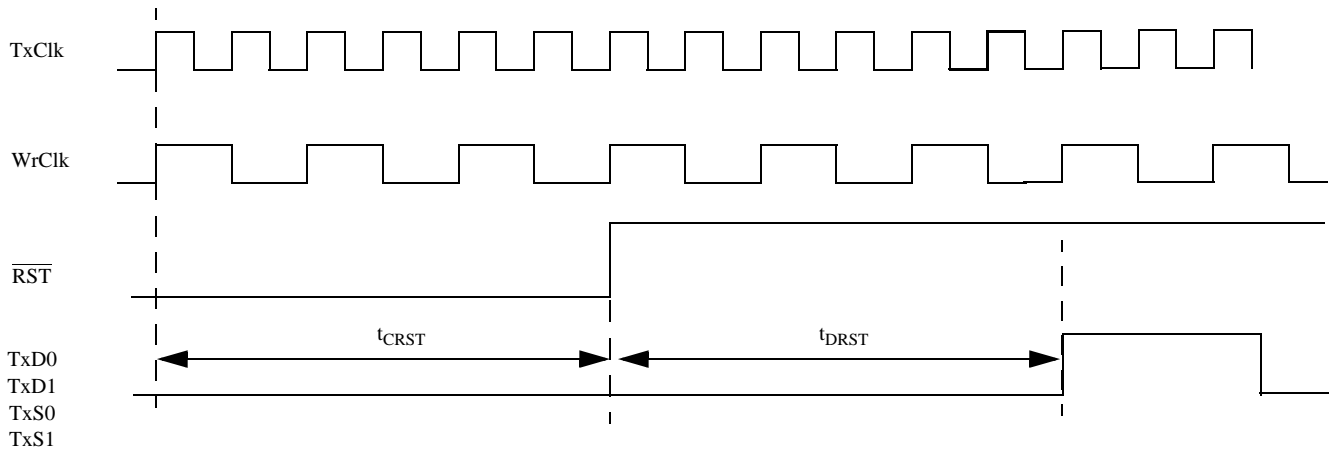


Figure 3. Driver Three-State Delay Time Test or Equivalent Circuit

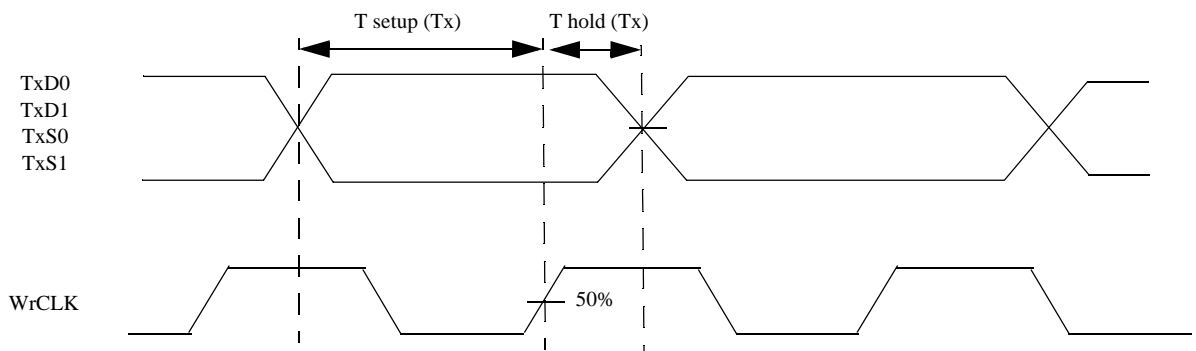




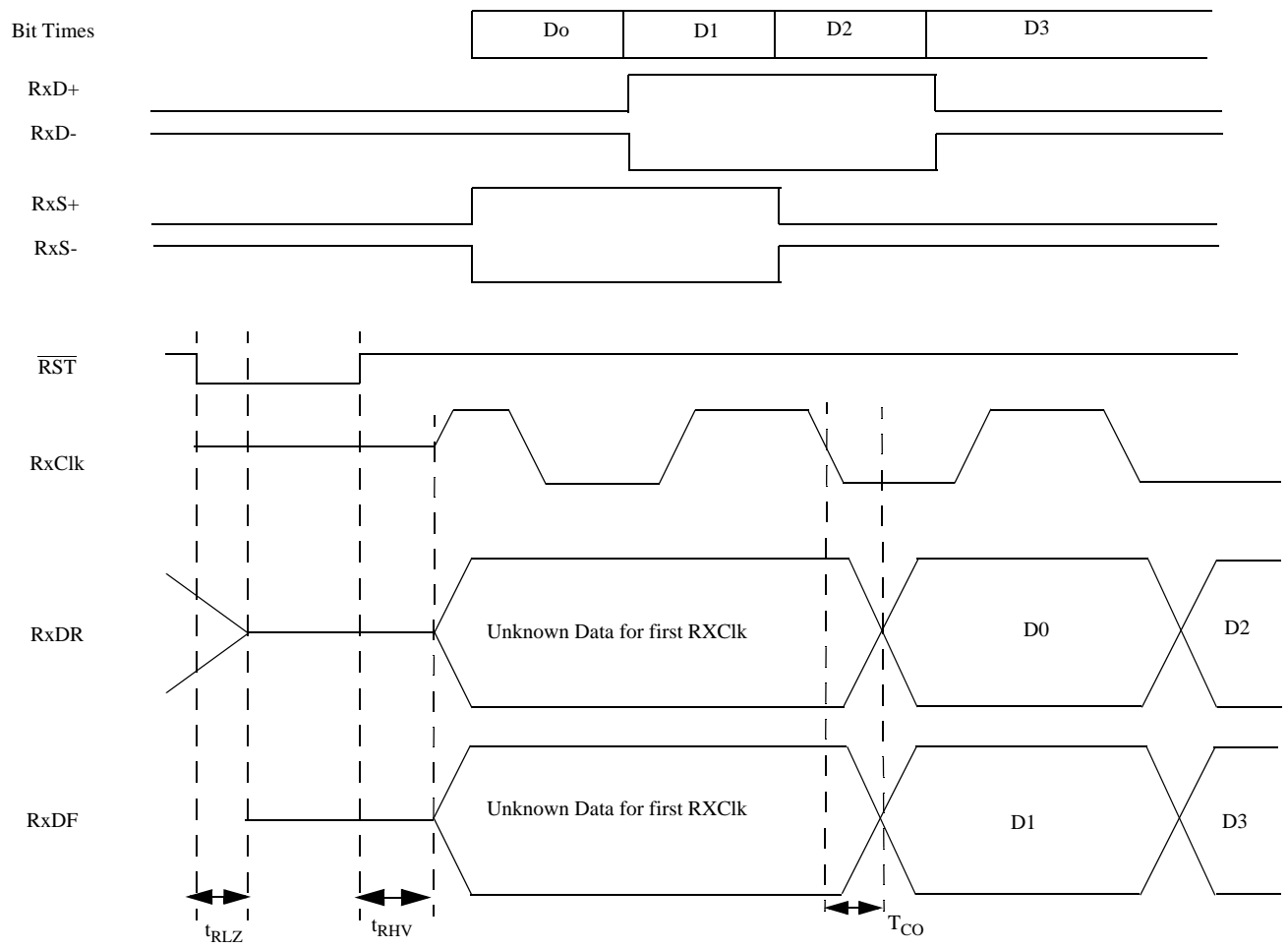
**Figure 4. Output Enable to Data Out Timing**



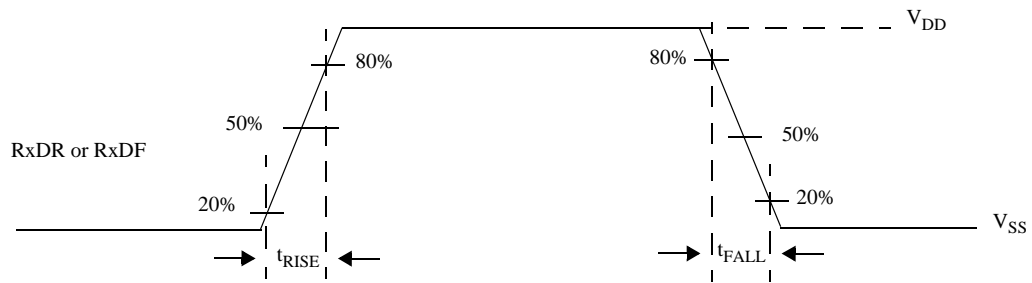
**Figure 5. Reset Timing Diagram**



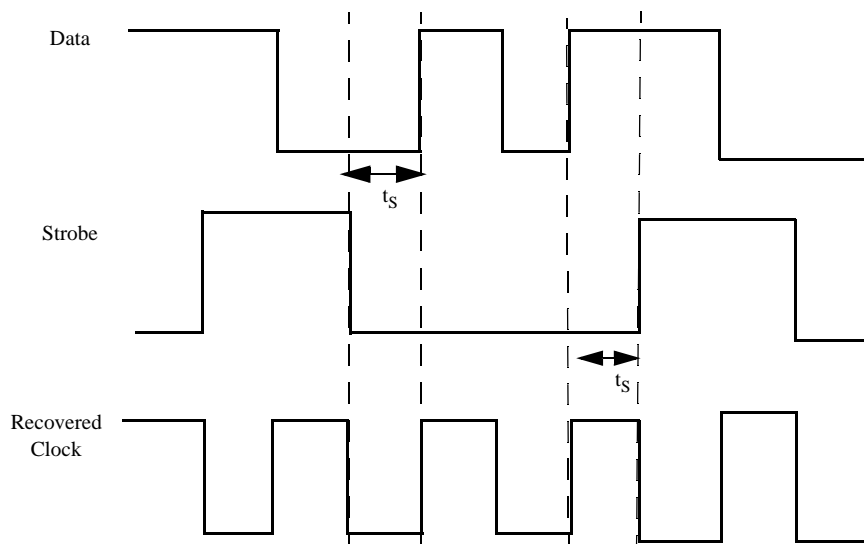
**Figure 6. Transmitter Input Timing Diagram**



**Figure 7. Receiver Output Timing Diagram**

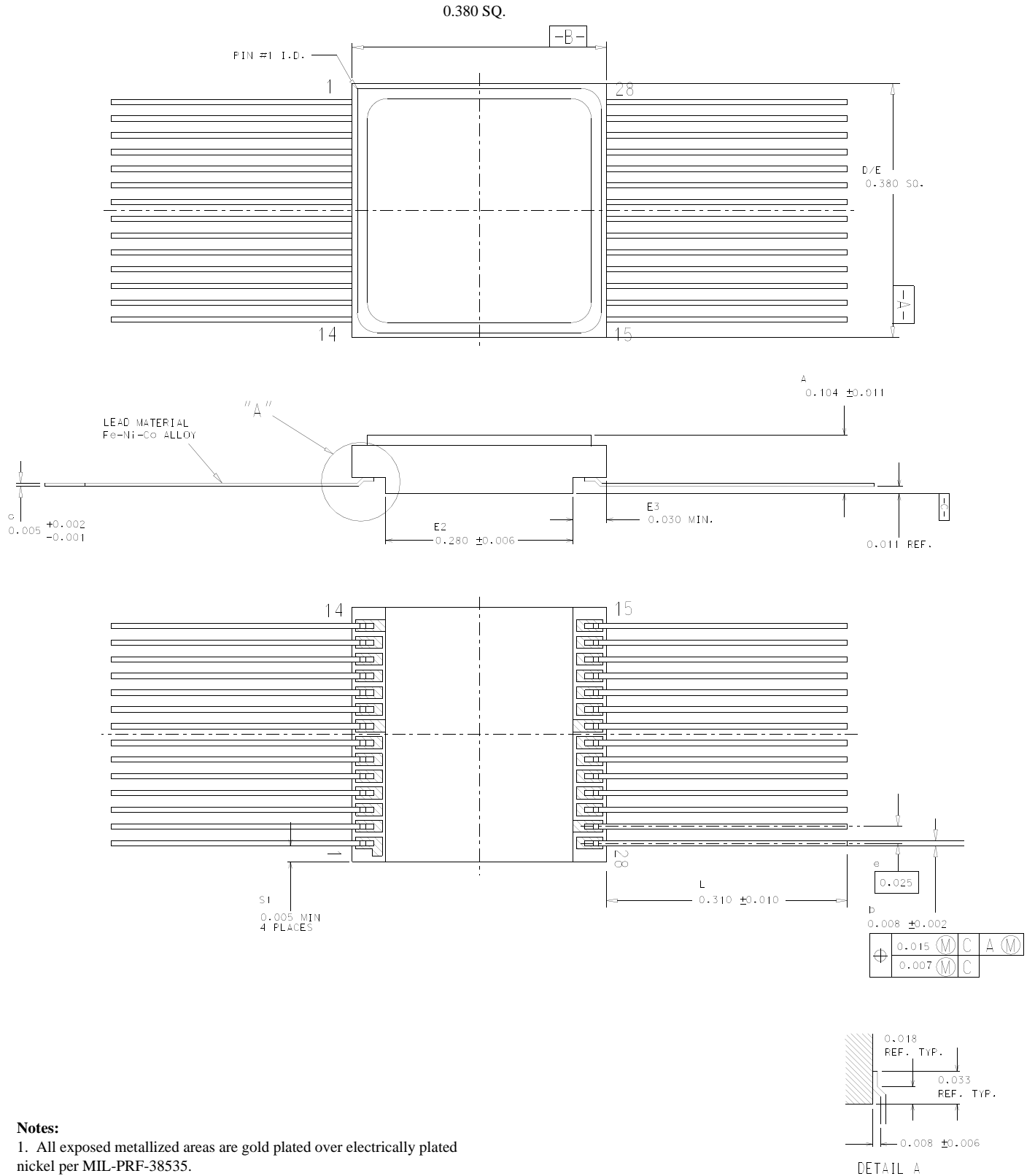


**Figure 8. Receiver Output Rise and Fall Times Waveform**



**Figure 9. Data/Strobe Separation**

# PACKAGING



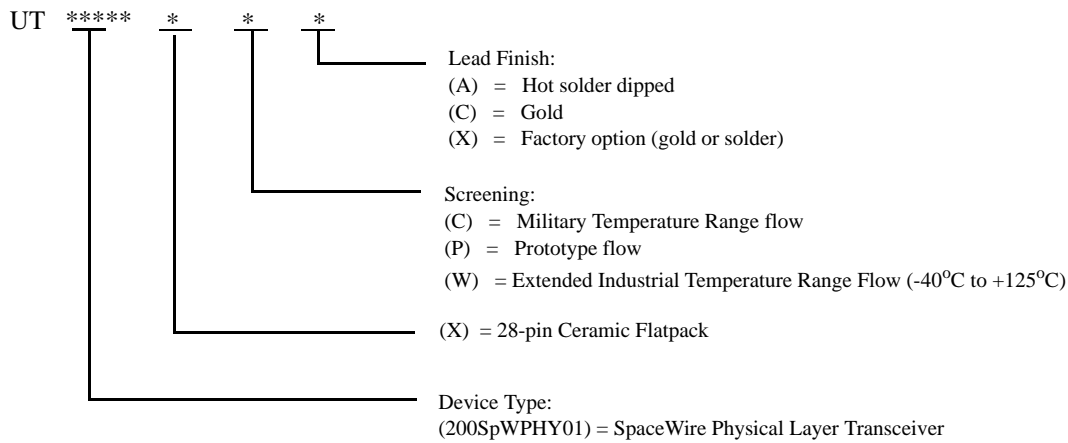
### Notes:

1. All exposed metallized areas are gold plated over electrically plated nickel per MIL-PRF-38535.
2. The lid is electrically connected to  $V_{SS}$ .
3. Lead finishes are in accordance with MIL-PRF-38535.
4. Dimension symbology is in accordance with MIL-PRF-38535.
5. Lead position and coplanarity are not measured.
6. ID mark symbol is vendor option: no alphanumerics.

**Figure 10. 28-pin Flatpack**

## ORDERING INFORMATION

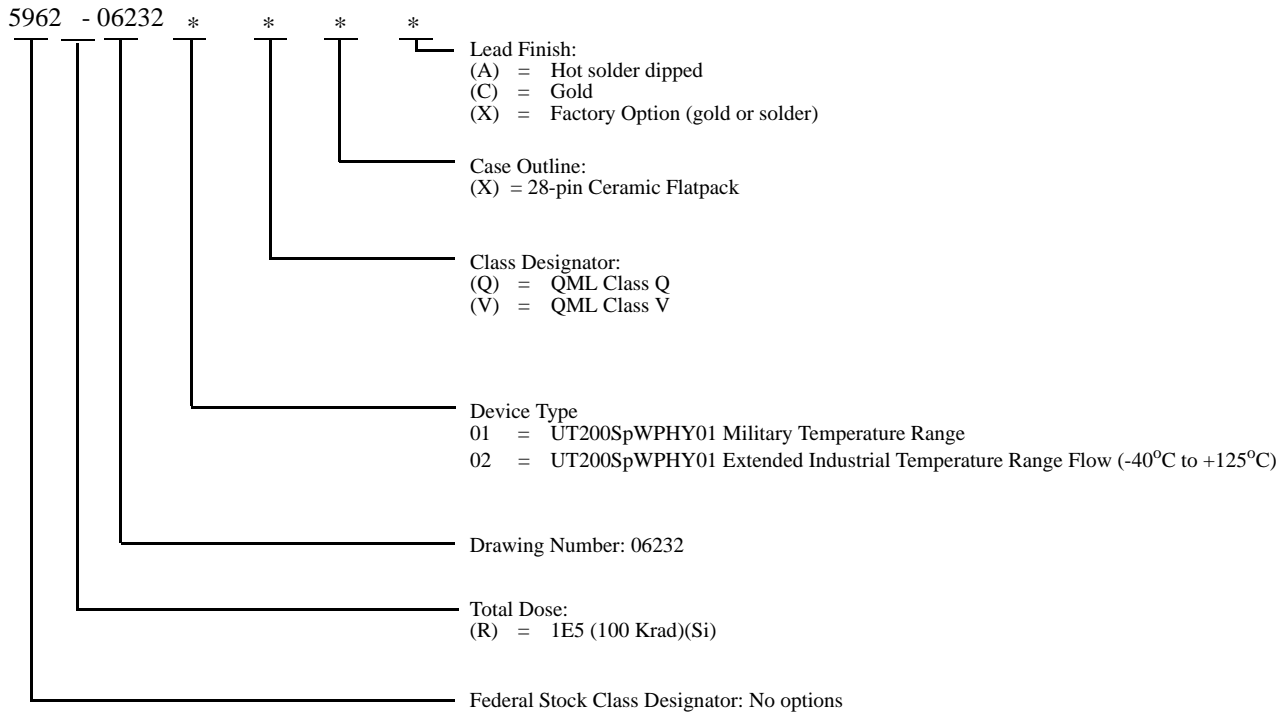
### UT200SpWPHY01: SpaceWire Physical Layer Transceiver



#### Notes:

1. Lead finish (A,C, or X) must be specified.
2. If an "X" is specified when ordering, then the part marking will match the lead finish and will be either "A" (solder) or "C" (gold).
3. Prototype flow per Aeroflex Manufacturing Flows Document. Tested at 25°C only. Lead finish is GOLD ONLY. Radiation neither tested nor guaranteed.
4. Military Temperature Range flow per Aeroflex Manufacturing Flows Document. Devices are tested at -55°C, room temp, and 125°C. Radiation neither tested nor guaranteed.
5. Extended Industrial Range flow per Aeroflex Colorado Springs Manufacturing Flows Document. Devices are tested at -40°C, room temp, and 125°C. Radiation neither tested nor guaranteed.

## UT200SpWPHY01: SMD



### Notes:

1. Lead finish (A, C, or X) must be specified.
2. If an "X" is specified when ordering, part marking will match the lead finish and will be either "A" (solder) or "C" (gold).
3. Total dose radiation must be specified when ordering. QML Q and QML V not available without radiation hardening.

## ***Aeroflex Colorado Springs - Datasheet Definition***

**Advanced Datasheet - Product In Development**

**Preliminary Datasheet - Shipping Prototype**

**Datasheet - Shipping QML & Reduced Hi-Rel**

### **COLORADO**

Toll Free: 800-645-8862  
Fax: 719-594-8468

### **INTERNATIONAL**

Tel: 805-778-9229  
Fax: 805-778-1980

### **NORTHEAST**

Tel: 603-888-3975  
Fax: 603-888-4585

### **SE AND MID-ATLANTIC**

Tel: 321-951-4164  
Fax: 321-951-4254

### **WEST COAST**

Tel: 949-362-2260  
Fax: 949-362-2266

### **CENTRAL**

Tel: 719-594-8017  
Fax: 719-594-8468

***www.aeroflex.com      info-ams@aeroflex.com***

Aeroflex Colorado Springs, Inc., reserves the right to make changes to any products and services herein at any time without notice. Consult Aeroflex or an authorized sales representative to verify that the information in this data sheet is current before using this product. Aeroflex does not assume any responsibility or liability arising out of the application or use of any product or service described herein, except as expressly agreed to in writing by Aeroflex; nor does the purchase, lease, or use of a product or service from Aeroflex convey a license under any patent rights, copyrights, trademark rights, or any other of the intellectual rights of Aeroflex or of third parties.



Our passion for performance is defined by three attributes represented by these three icons: solution-minded, performance-driven and customer-focused