

**Dual Adjustable Positive/Negative Voltage Regulators
Radiation Tolerant**

www.aeroflex.com/voltreg

September 9, 2011



FEATURES

- Manufactured using  Linear Technology Corporation® Space Qualified RH117 and RH137 die
- Radiation performance
 - Total dose: 100 krad(Si), Dose rate = 50 - 300 rads(Si)/s
 - ELDRS: 50 krad(Si), Dose rate ≤ 10 mrad(Si)/s
- Two-Independent voltage regulators
- Thermal shutdown
- 1.5A output current
- Adjustable Output Voltages
- **Packaging** – Hermetic metal
 - Thru-hole or Surface mount
 - 6 Leads, .655"L x .415"W x .200"Ht
 - Power package
 - Weight - 5 gm max
- Designed for aerospace and high reliability space applications
- **Aeroflex Plainview's Radiation Hardness Assurance Plan is DLA Certified to MIL-PRF-38534, Appendix G.**

- **Positive** regulator features (RH117)
 - Output voltage adjustable: +1.25V to 37V
 - 3-Terminal
 - Voltage reference: 1.25V
 - Load regulation: 1.9% max
 - Line regulation: 0.06% max
 - Ripple rejection: >66dB
- **Negative** regulator features (RH137)
 - Output voltage adjustable: -1.25V to -27V
 - 3-Terminal
 - Voltage reference: 1.25V
 - Load regulation: 1.0% typ
 - Line regulation: .05% typ
 - Ripple rejection: >66dB

DESCRIPTION

The Aeroflex Plainview VGR8601/02 consists of a positive (RH117) and a negative (RH137) voltage regulator each capable of supplying in excess of 1.5Amps over the output voltage range as defined under recommended operating conditions. Each regulator is exceptionally easy to set-up, requiring only 2 external resistors to set the output voltage. The module design has been optimized for excellent regulation and low thermal transients. There is full electrical isolation between positive and negative regulators and each regulator to the package.

Further, the VRG8601/02 features internal current limiting, thermal shutdown and safe-area compensation, making them virtually blowout-proof against overloads. The VRG8601/02 serves a wide variety of applications including local on-card regulation, programmable output voltage regulation or precision current regulation.

The VRG8601/02 has been specifically designed to meet exposure to radiation environments. The VRG8601 is configured for a Thru-Hole 6 lead metal power package and the VRG8602 is configured for a Surface Mount 6 lead metal power package. It is guaranteed operational from -55°C to +125°C. Available screened to MIL-STD-883, the VRG8601/02 is ideal for demanding military and space applications.

For detailed performance characteristic curves, applications information and typical applications see the latest  Linear Technology Corporation® data sheets for their RH/LT117 and RH/LT137, which is available on-line at www.linear.com.

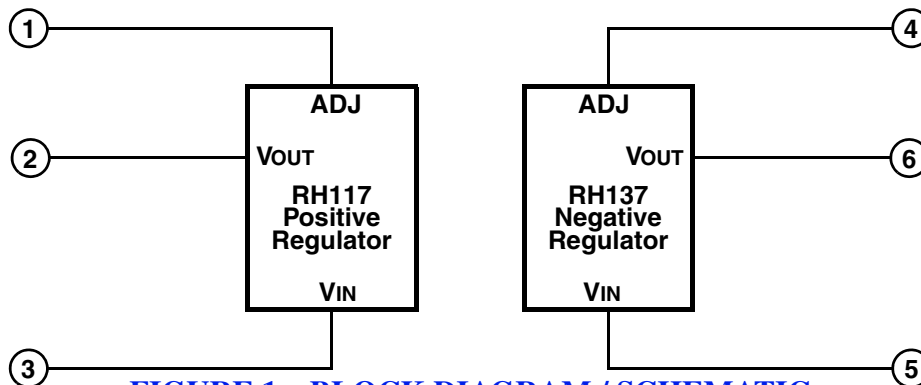

FIGURE 1 – BLOCK DIAGRAM / SCHEMATIC

ABSOLUTE MAXIMUM RATINGS

PARAMETER	RANGE	UNITS
Operating (Junction) Temperature Range	-55 to +150	°C
Lead Temperature (soldering, 10 sec)	300	°C
Storage Temperature Range	-65 to +150	°C
Input-Output Voltage Differential	40 (Pos) 30 (Neg)	V
Thermal Resistance (junction to case Θ_{JC}) each, Pos. & Neg.	5	°C/W
ESD Rating	1,999 ^{1/}	KV

^{1/} Meets ESD testing per MIL-STD-883, method 3015, Class 1C.

NOTICE: Stresses above those listed under "Absolute Maximums Rating" may cause permanent damage to the device. These are stress rating only; functional operation beyond the "Operation Conditions" is not recommended and extended exposure beyond the "Operation Conditions" may effect device reliability..

RECOMMENDED OPERATING CONDITIONS

PARAMETER	RANGE	UNITS
Output Voltage Range		
Positive Voltage Regulator	1.3 to 37	VDC
Negative Voltage Regulator	-1.3 to -27	VDC
Case Operating Temperature Range	-55 to +125	°C

POSITIVE REGULATOR – ELECTRICAL PERFORMANCE CHARACTERISTICS ^{1/}

PARAMETER	SYM	CONDITIONS (P ≤ P _{MAX})	MIN	MAX	UNITS
Reference Voltage ^{4/}	V _{REF}	3V ≤ (V _{IN} - V _{OUT}) ≤ V _{DIFF MAX} , 10mA ≤ I _{OUT} ≤ I _{MAX}	1.20	1.30	V
Line Regulation ^{2/ 4/}	$\frac{\Delta V_{OUT}}{\Delta V_{IN}}$	3V ≤ (V _{IN} - V _{OUT}) ≤ V _{DIFF MAX} , I _{OUT} = 10mA	-	0.03	%/V
Load Regulation ^{2/ 4/}	$\frac{\Delta V_{OUT}}{\Delta I_{OUT}}$	10mA ≤ I _{OUT} ≤ I _{MAX} , V _{OUT} ≤ 5V 10mA ≤ I _{OUT} ≤ I _{MAX} , V _{OUT} ≥ 5V	- -	60 1.2	mV %
Thermal Regulation		I _{OUT} = 1.5A, (V _{IN} - V _{OUT}) = 13.3V, 20ms Pulse, 20W, T _C = +25°C	-	0.07	%/W
Ripple Rejection Ratio		V _{OUT} = 10V, f = 120Hz, C _{ADJ} = 10μF	66	-	dB
Adjustment Pin Current ^{4/}	I _{ADJ}	I _{OUT} = 10mA, 3V ≤ (V _{IN} - V _{OUT}) ≤ 40V	-	100	μA
Adjustment Pin Current Change ^{4/}	ΔI _{ADJ}	10mA ≤ I _{OUT} ≤ I _{MAX} 3V ≤ (V _{IN} - V _{OUT}) ≤ 40V	-	5	μA
Minimum Load Current ^{3/ 4/}	I _{MIN}	(V _{IN} - V _{OUT}) = 40V	-	5	mA
Current Limit ^{4/ 5/}	I _{MAX}	(V _{IN} - V _{OUT}) ≤ 15V	1.5	-	A
		(V _{IN} - V _{OUT}) = 40V, T _C = +25°C	0.30	-	
Long Term Stability ^{3/}	$\frac{\Delta V_{OUT}}{\Delta TIME}$	T _C = +125°C	-	1	%
Thermal Resistance, each Regulator (Junction to Case) ^{3/}	Θ _{JC}		-	5	°C/W

NEGATIVE REGULATOR – ELECTRICAL PERFORMANCE CHARACTERISTICS 1/

PARAMETER	SYM	CONDITIONS	MIN	MAX	UNITS
Reference Voltage <u>4/</u>	V _{REF}	$3V \leq (V_{IN} - V_{OUT}) \leq V_{DIFF\ MAX}, 10mA \leq I_{OUT} \leq I_{MAX}$	-1.200	-1.300	V
Line Regulation <u>2/ 4/</u>	$\frac{\Delta V_{OUT}}{\Delta V_{IN}}$	$3V \leq (V_{IN} - V_{OUT}) \leq 30V,$	-	0.05	%/V
Load Regulation <u>2/ 4/</u>	$\frac{\Delta V_{OUT}}{\Delta I_{OUT}}$	$10mA \leq I_{OUT} \leq I_{MAX}, V_{OUT} \leq 5V$	-	50	mV
		$10mA \leq I_{OUT} \leq I_{MAX}, V_{OUT} \geq 5V$	-	1.0	%
Thermal Regulation		$I_{OUT} = 1.5A, (V_{IN} - V_{OUT}) = 13.3V, 20ms\ Pulse, 20W,$ $T_C = +25^\circ C$	-	0.02	%/W
Ripple Rejection		$V_{OUT} = -10V, f = 120Hz, C_{ADJ} = 10\mu F$	66	-	dB
Adjustment Pin Current <u>4/</u>	I _{ADJ}	$I_{OUT} = 10mA, 3V \leq (V_{IN} - V_{OUT}) \leq 30V$	-	100	μA
Adjustment Pin Current Change <u>4/</u>	ΔI_{ADJ}	$10mA \leq I_{OUT} \leq I_{MAX}$ $3V \leq (V_{IN} - V_{OUT}) \leq 30V$	-	5	μA
Minimum Load Current <u>3/ 4/</u>	I _{MIN}	$(V_{IN} - V_{OUT}) = 30V$	-	5	mA
		$(V_{IN} - V_{OUT}) \leq 10V$	-	3	
Current Limit <u>4/ 5/</u>	I _{MAX}	$(V_{IN} - V_{OUT}) \leq 15V$	1.5	-	A
		$(V_{IN} - V_{OUT}) = 30V, T_C = +25^\circ C$	0.24	-	
Long Term Stability <u>3/</u>	$\frac{\Delta V_{OUT}}{\Delta TIME}$	$T_C = +125^\circ C$	-	1	%
Thermal Resistance, each Regulator (Junction to Case) <u>3/</u>	Θ_{JC}		-	5	$^\circ C/W$

Notes:

1/ Unless otherwise specified, these specifications apply for $(V_{in} - V_{out}) = 5V, I_{out} = 0.5A$ and $-55^\circ C < T_c < +125^\circ C$.

2/ Regulation is measured at a constant junction temperature, using pulse testing with a low duty cycle. Changes in output voltage due to heating effects are covered under the specification for thermal regulation. Measurements taken at the output lead must be adjusted for lead resistance.

3/ Not tested. Shall be guaranteed to the specified limits.

4/ Specification derated to reflect High Dose Rate (1019 condition A) to 100 krad(Si) and Low Dose Rate (1019 condition D) to 50 krad(Si), @ $+25^\circ C$.

5/ Pulsed @ $< 10\%$ duty cycle @ $+25^\circ C$.

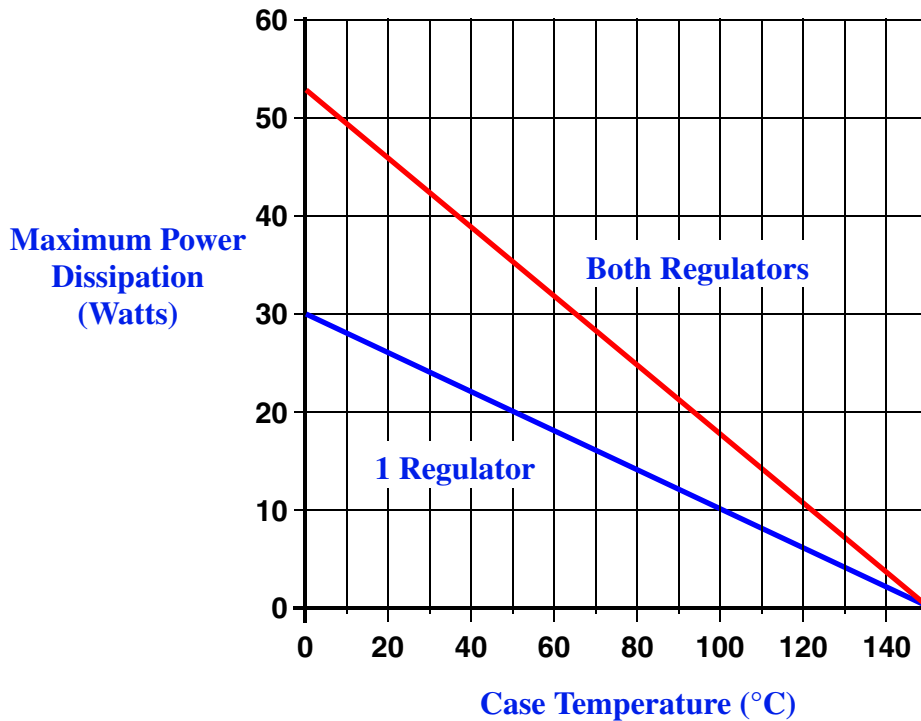
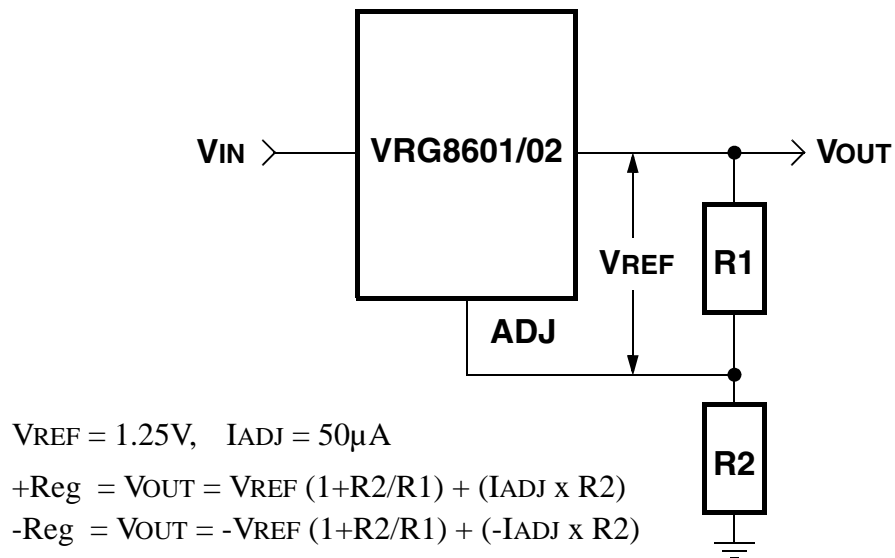

FIGURE 2 – MAXIMUM POWER vs CASE TEMPERATURE

The maximum Power dissipation is limited by the thermal shutdown function of each regulator chip in the VRG8601/02. The graph above represents the achievable power before the chip shuts down. The first line in the graph represents the maximum power dissipation of the VRG8601/02 with one regulator on (the other off) and the other line represents both regulators on dissipating equal power. If both regulators are on and one regulator is dissipating more power than the other, the maximum power dissipation of the VRG8601/02 will fall between the two lines. This graph is based on the maximum junction temperature of 150°C and a thermal resistance (Θ_{JC}) of 5°C/W.



Adjustable Regulator

FIGURE 3 – TYPICAL APPLICATIONS

PIN NUMBERS vs FUNCTION

PIN	FUNCTION
1	POS_ADJ_1
2	POS_VOUT_1
3	POS_VIN_1
4	NEG_ADJ_2
5	NEG_VIN_2
6	NEG_VOUT_2

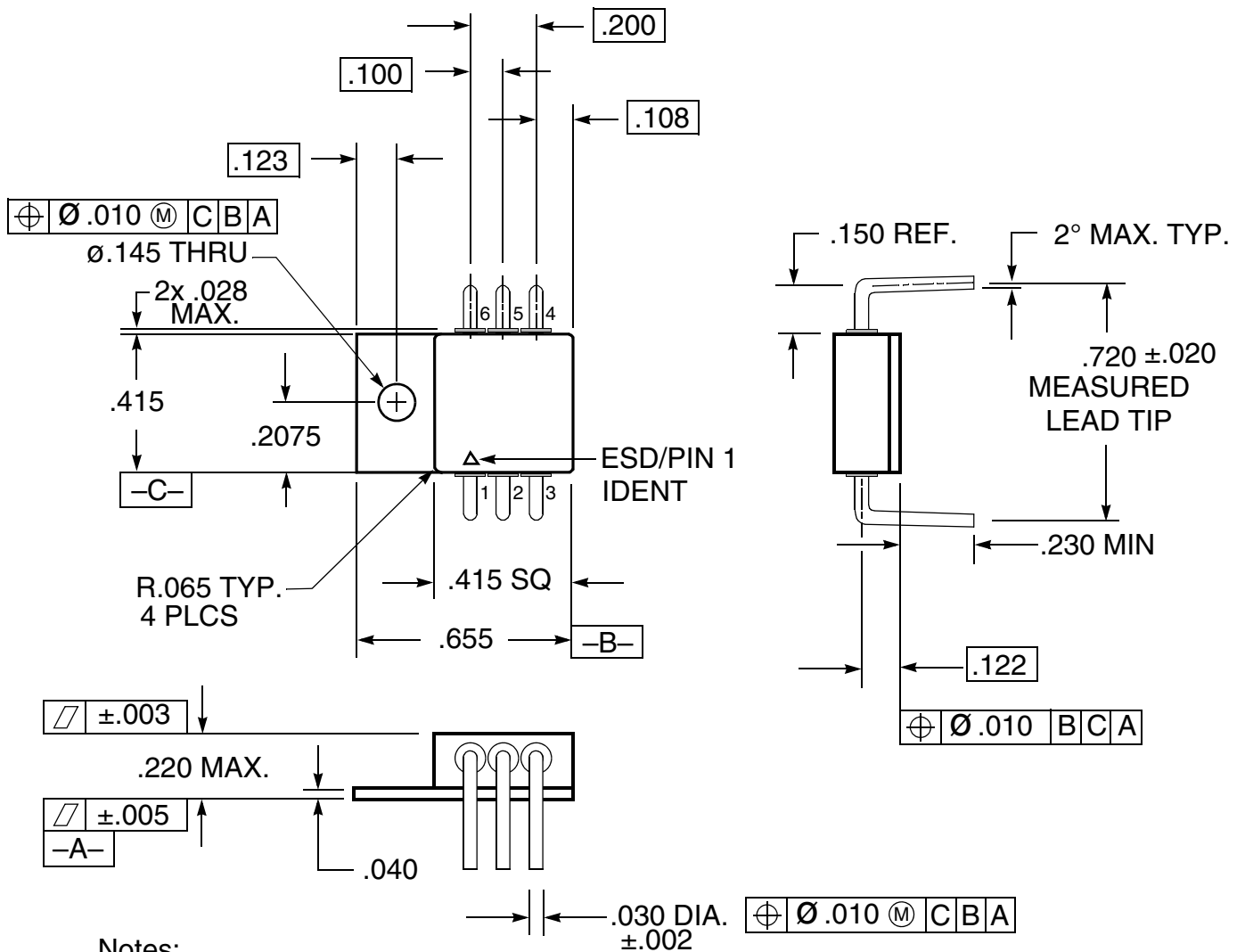

Notes:

1. Dimension Tolerance: $\pm .005$ inches
2. Package contains BeO substrate
3. Case electrically isolated

FIGURE 4 – PACKAGE OUTLINE — THRU-HOLE POWER PACKAGE

PIN NUMBERS vs FUNCTION

PIN	FUNCTION
1	POS_ADJ_1
2	POS_VOUT_1
3	POS_VIN_1
4	NEG_ADJ_2
5	NEG_VIN_2
6	NEG_VOUT_2

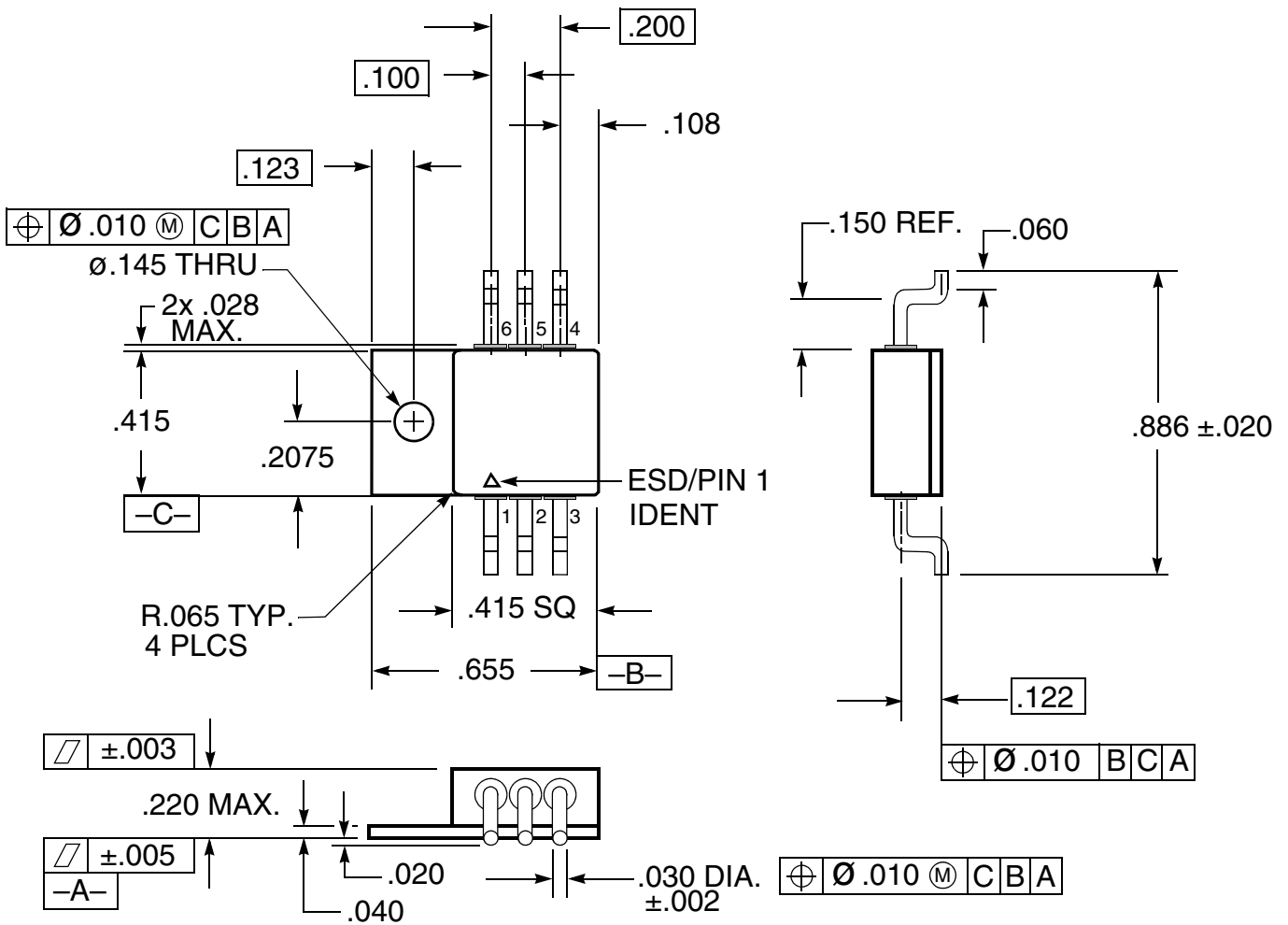

Notes:

1. Dimension Tolerance: $\pm .005$ inches
2. Package contains BeO substrate
3. Case electrically isolated

FIGURE 5 – PACKAGE OUTLINE — SURFACE MOUNT POWER PACKAGE

ORDERING INFORMATION

MODEL	DLA SMD #	SCREENING	PACKAGE
VRG8601-7	-	Commercial Flow, +25°C testing only	6 Lead Thru-Hole Power Pkg
VRG8601-S	-	Military Temperature, -55°C to +125°C Screened in accordance with the individual Test Methods of MIL-STD-883 for Space Applications	
VRG8601-201-1S	5962-0521901KXC	In accordance with DLA SMD	
VRG8601-201-2S	5962-0521901KXA		
VRG8601-901-1S	5962R0521901KXC	In accordance with DLA Certified RHA Program Plan to RHA level "R", 100 krad(Si)	
VRG8601-901-2S	5962R0521901KXA		
VRG8602-7	-	Commercial Flow, +25°C testing only	6 Lead Surface Mount Power Pkg
VRG8602-S	-	Military Temperature, -55°C to +125°C Screened in accordance with the individual Test Methods of MIL-STD-883 for Space Applications	
VRG8602-201-1S	5962-0521901KYC	In accordance with DLA SMD	
VRG8602-201-2S	5962-0521901KYA		
VRG8602-901-1S	5962R0521901KYC	In accordance with DLA Certified RHA Program Plan to RHA level "R", 100 krad(Si)	
VRG8602-901-2S	5962R0521901KYA		

EXPORT CONTROL:

This product is controlled for export under the International Traffic in Arms Regulations (ITAR). A license from the U.S. Department of State is required prior to the export of this product from the United States.

EXPORT WARNING:

Aeroflex's military and space products are controlled for export under the International Traffic in Arms Regulations (ITAR) and may not be sold or proposed or offered for sale to certain countries. (See ITAR 126.1 for complete information.)

PLAINVIEW, NEW YORK

Toll Free: 800-THE-1553
Fax: 516-694-6715

INTERNATIONAL

Tel: 805-778-9229
Fax: 805-778-1980

NORTHEAST

Tel: 603-888-3975
Fax: 603-888-4585

SE AND MID-ATLANTIC

Tel: 321-951-4164
Fax: 321-951-4254

WEST COAST

Tel: 949-362-2260
Fax: 949-362-2266

CENTRAL

Tel: 719-594-8017
Fax: 719-594-8468



www.aeroflex.com info-ams@aeroflex.com

Aeroflex Microelectronic Solutions reserves the right to change at any time without notice the specifications, design, function, or form of its products described herein. All parameters must be validated for each customer's application by engineering. No liability is assumed as a result of use of this product. No patent licenses are implied.



Our passion for performance is defined by three attributes represented by these three icons: solution-minded, performance-driven and customer-focused

 and the Linear Technology logo are registered trademarks and RH117 & RH137 are a copyright of Linear Technology Corporation.