

Standard Products

VRG8666

Voltage Regulator, 1.0 Amp, Positive Ultra Low Dropout (ULDO), Adjustable Radiation Tolerant

www.aeroflex.com/voltreg

December 12, 2012

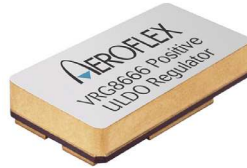

AEROFLEX
A passion for performance.

FEATURES

- ❑ Manufactured using  Space Qualified RH3080 die
- ❑ Radiation performance
 - ♦ Total dose: 100 krad(Si), Dose rate = 50 - 300 rads(Si)/s
 - ♦ ELDRS: 50 krad(Si), Dose rate \leq 0.01 rads(Si)/s
- ❑ Current Limit with Foldback and Over-temperature protection
- ❑ Output voltage adjustable: 0V to 36V
- ❑ Outputs may be paralleled for higher current
- ❑ Post Radiated Dropout voltage:
 - ♦ 0.60V @ 1.0Amps
 - ♦ 0.39V @ 0.5Amps
- ❑ Output current: 1.0Amps
- ❑ Packaging – Hermetic Ceramic
 - ♦ Hermetic Surface Mount Power
 - ♦ 5 Pads, .545"L x .296"W x .120"Ht
 - ♦ Weight - 2.0 gm max
- ❑ Designed for aerospace and high reliability space applications

- ❑ Aeroflex Plainview's Radiation Hardness Assurance Plan is DLA Certified to MIL-PRF-38534, Appendix G.

DESCRIPTION

The Aeroflex Plainview VRG8666 consists of a Positive Adjustable (RH3080) ULDO voltage regulator capable of supplying 1.0Amps over the output voltage range as defined under recommended operating conditions. The VRG8666 offers excellent line and load regulation specifications and ripple rejection.

The VRG8666 serves a wide variety of applications including SCSI-2 Active Terminator, High Efficiency Linear Regulators, Post Regulators for Switching Supplies, Constant Current Regulators, Battery Chargers and Microprocessor Supply.

The VRG8666 has been specifically designed to meet exposure to radiation environments and is configured for an SMD power package. It is guaranteed operational from -55°C to +125°C. Available screened to MIL-STD-883, the VRG8666 is ideal for demanding military and space applications.

Dropout ($V_{IN} - V_{OUT}$) decreases at lower load currents.

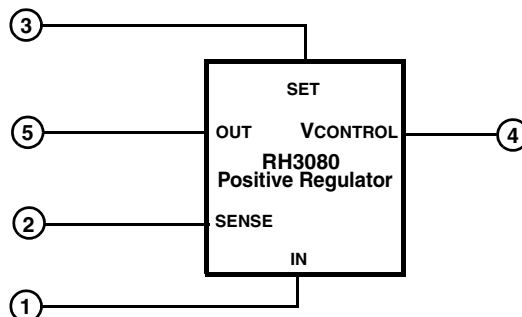

FIGURE 1 – BLOCK DIAGRAM / SCHEMATIC

ABSOLUTE MAXIMUM RATINGS

Parameter	Rating	Units
Input Voltage, V _{CONTROL} (Voltages are Relative to V _{OUT})	+40, -0.3	VDC
Output Short Circuit Duration	Indefinite	-
Lead temperature (soldering 10 Sec)	300	°C
Input Output Differential	26	VDC
Output Voltage	+36	VDC
ESD <u>1/</u>	2,000 - 3,999	V
Operating Junction Temperature Range	-55 to +150	°C
Storage Temperature Range	-65 to +150	°C
Thermal Resistance (Junction to Case) Θ_{JC}	5	°C/W

1/ Meets ESD testing per MIL-STD-883, method 3015, Class 2.

NOTICE: Stresses above those listed under "Absolute Maximum Ratings" may cause permanent damage to the device. These are stress rating only; functional operation beyond the "Operation Conditions" is not recommended and extended exposure beyond the "Operation Conditions" may effect device reliability.

RECOMMENDED OPERATING CONDITIONS

Parameter	Range	Units
Output Voltage Range	0 to 35	VDC
Input Output Differential	0.5 to 26	VDC
Case Operating Temperature Range	-55 to +125	°C
Input Voltage (Voltages are Relative to V _{OUT})	1 to 36	V
V _{CONTROL} (Voltages are Relative to V _{OUT})	2 to 36	V

ELECTRICAL PERFORMANCE CHARACTERISTICS

Unless otherwise specified: -55°C ≤ T_c ≤ +125°C.

Parameter	Symbol	Conditions (P ≤ P _{MAX})	Min	Max	Units
Set Pin Current	I _{REF1}	1.0mA ≤ I _{LOAD} ≤ 1.0A, (V _{IN} - V _{OUT}) = 1.6V	9.8	10.2	μA
Set Pin Current <u>1/</u>	I _{REF2}	V _{IN} = 1V, V _{CONTROL} = 2V, I _{LOAD} = 1mA	9.8	10.2	μA
Output Offset Voltage (V _{OUT} - V _{SET}) <u>1/</u>	V _{OS}	V _{IN} = 1V, V _{CONTROL} = 2V, I _{LOAD} = 1mA,	-9.0	9.0	mV
Line Regulation <u>1/</u>	ΔV _{OS}	1V ≤ V _{IN} ≤ 26V, 2V ≤ V _{CONTROL} ≤ 26V, I _{LOAD} = 1mA, T _J = +25°C	-0.15	0.15	mV/V
Load Regulation <u>1/</u>	ΔV _{OS}	(V _{IN} - V _{OUT}) = 3V, I _{LOAD} = 1mA to 0.1A	-1.4	1.4	mV
V _{CONTROL} Dropout Voltage	V _{CDROP}	I _{LOAD} = 1.0A	-	1.60	V
		I _{LOAD} = 0.1A <u>1/</u>	-	1.60	
V _{IN} Dropout Voltage	V _{INDROP}	I _{LOAD} = 1.0A	-	0.5	V
		I _{LOAD} = 0.1A <u>1/</u>	-	0.25	
Current Limit <u>3/</u>	I _{MAX}	V _{IN} = V _{CONTROL} = +5V, V _{SET} = 0V, V _{OUT} = -0.1V	1.1	-	A
Minimum Load Current <u>1/</u> <u>4/</u>	I _{MIN}	V _{IN} = V _{CONTROL} = 26V, V _{OUT} = 0.1V	-	0.9	mA
Ripple Rejection	-	I _{LOAD} = 0.2A, (V _{IN} - V _{OUT}) = 3V, f = 120Hz, C _{OUT} = 2.2μF, C _{SET} = 0.1μF	60	-	dB
Thermal Regulation	-	30ms pulse, T _C = +25°C	-	0.03	%/W

Notes:

1/ Specification derated to reflect Total Dose exposure to 100 Krad (Si) @+25°C.

2/ Dropout results from either minimum control voltage, V_{CONTROL}, or minimum input voltage, V_{IN}, both specified with respect to V_{OUT}. These specifications represent the minimum input-to-output differential voltage required to maintain regulation.

3/ Pulsed @ <10% duty cycle @ +25°C for characterization only. (See note 1/).

4/ Not tested. Shall be quaranteed to the specified limits.

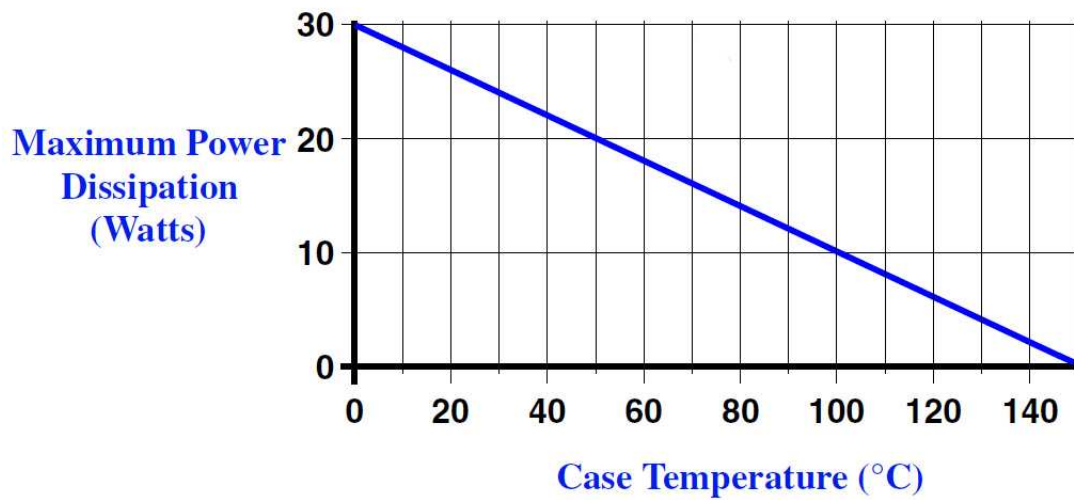

FIGURE 2 – MAXIMUM POWER vs CASE TEMPERATURE

The maximum Power dissipation is limited by the thermal shutdown function of the regulator chip in the VRG8666. The graph above represents the achievable power before the chip shuts down. The line in the graph represents the maximum power dissipation of the VRG8666. This graph is based on the maximum junction temperature of 150°C and a thermal resistance (θ_{JC}) of 5°C/W.

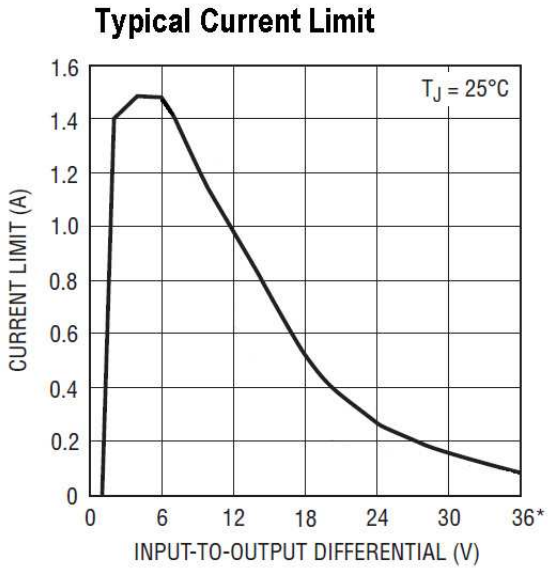

FIGURE 3 – RH3080 CURRENT LIMIT

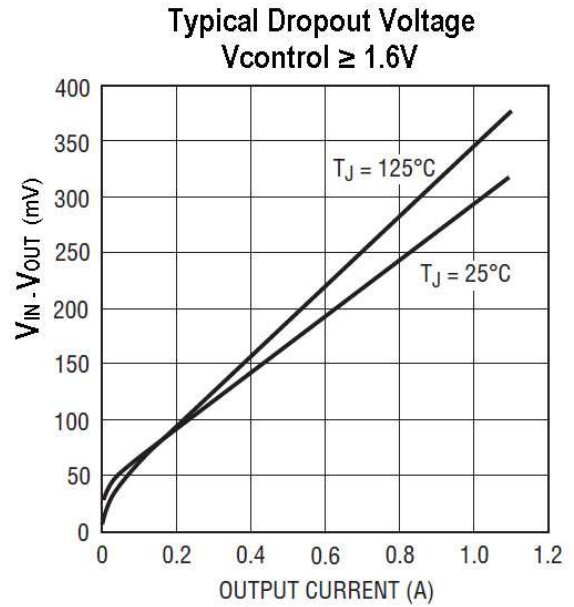

FIGURE 4 – RH3080 TYPICAL DROPOUT VOLTAGE CURVE

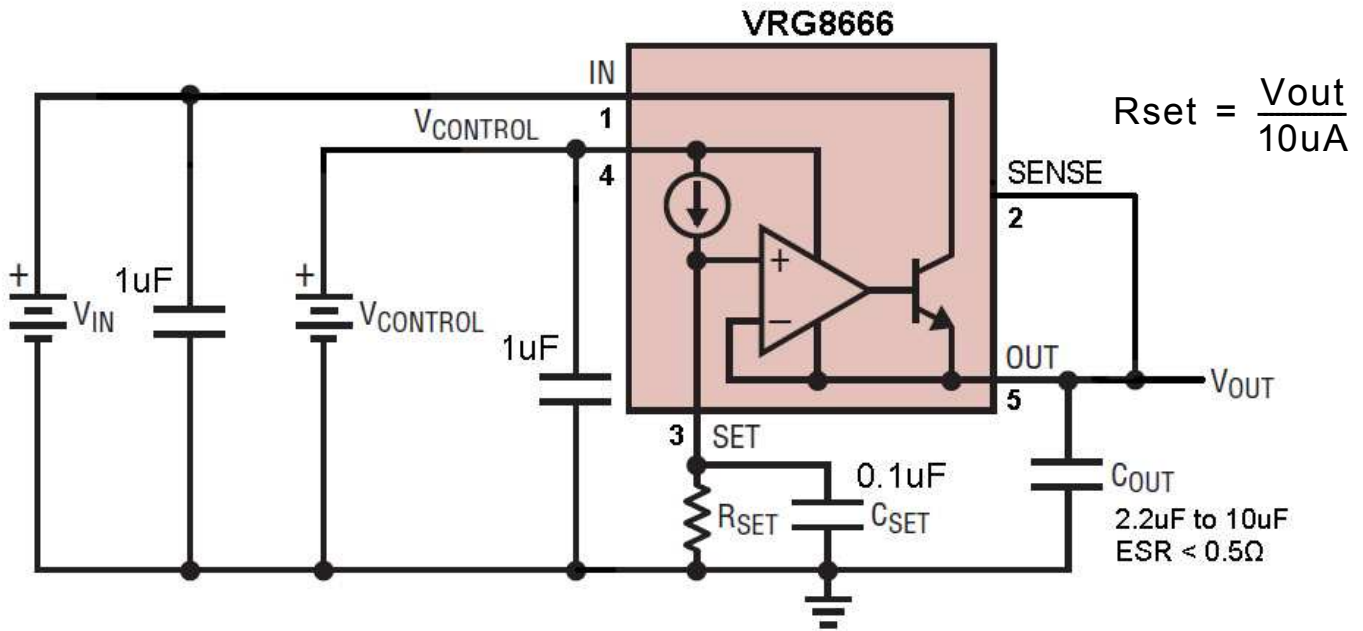



FIGURE 5 – BASIC VRG8666 ADJUSTABLE REGULATOR APPLICATION

ORDERING INFORMATION

Model	DLA SMD #	Screening	Package
VRG8666-7	-	Commercial Flow, +25°C testing only	SMD Power Pkg
VRG8666-S	-	Military Temperature, -55°C to +125°C Screened in accordance with the individual Test Methods of MIL-STD-883 for Space Applications	
VRG8666-201-1S	5962-1120501KYC	In accordance with DLA SMD	
VRG8666-201-2S	5962-1120501KYA		
VRG8666-901-1S	5962R1120501KYC	In accordance with DLA Certified RHA Program Plan to RHA Level "R", 100krads(Si)	
VRG8666-901-2S	5962R1120501KYA		

For detailed performance characteristic curves, applications information and typical applications see the latest  datasheets for their RH3080, which is available on-line at www.linear.com.

EXPORT CONTROL:

This product is controlled for export under the International Traffic in Arms Regulations (ITAR). A license from the U.S. Department of State is required prior to the export of this product from the United States.

EXPORT WARNING:

Aeroflex's military and space products are controlled for export under the International Traffic in Arms Regulations (ITAR) and may not be sold or proposed or offered for sale to certain countries. (See ITAR 126.1 for complete information.)

PLAINVIEW, NEW YORK
Toll Free: 800-THE-1553
Fax: 516-694-6715

INTERNATIONAL
Tel: 805-778-9229
Fax: 805-778-1980

NORTHEAST
Tel: 603-888-3975
Fax: 603-888-4585

SE AND MID-ATLANTIC
Tel: 321-951-4164
Fax: 321-951-4254

WEST COAST
Tel: 949-362-2260
Fax: 949-362-2266

CENTRAL
Tel: 719-594-8017
Fax: 719-594-8468



www.aeroflex.com info-ams@aeroflex.com

Aeroflex Microelectronic Solutions reserves the right to change at any time without notice the specifications, design, function, or form of its products described herein. All parameters must be validated for each customer's application by engineering. No liability is assumed as a result of use of this product. No patent licenses are implied.



Our passion for performance is defined by three attributes represented by these three icons: solution-minded, performance-driven and customer-focused

LT, LTC, , Linear Technology and the Linear logo are registered trademarks and RH3080 is copyright Linear Technology Corporation.