

DATA SHEET

SKY13316-12LF: GaAs IC SPST Non-Reflective Switch 300 kHz–2.5 GHz

Features

- High isolation (50 dB @ 900 MHz)
- J1 reflective (open) in isolation state
- J2 non-reflective in isolation state
- Available lead (Pb)-free and RoHS-compliant MSL-1 @ 260 °C per JEDEC J-STD-020

Description

The SKY13316-12LF is a non-reflective SPST switch designed for low cost, low power commercial applications. It is ideal for use as a building block for high isolation multi-throw switches.

NEW Skyworks offers lead (Pb)-free, RoHS (Restriction of Hazardous Substances)-compliant packaging.



Functional Block Diagram

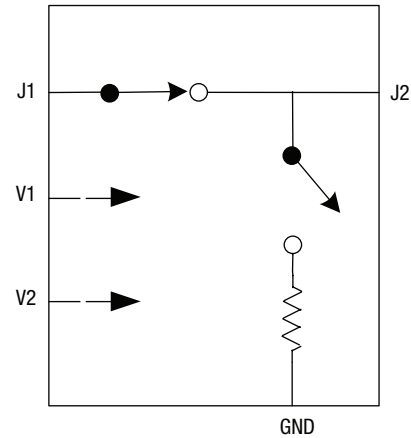

Electrical Specifications

$V_{CTL} = 0\text{ V}/-5\text{ V}$, $T = 25\text{ °C}$, $P_{INPUT} = 0\text{ dBm}$, $Z_0 = 50\text{ }\Omega$, unless otherwise noted

Parameter	Frequency	Min.	Typ.	Max.	Unit
Insertion loss	300 kHz–0.5 GHz		0.5	0.9	dB
	300 kHz–1.0 GHz		0.6	1.0	dB
	300 kHz–2.5 GHz		0.75	1.2	dB
Isolation	300 kHz–0.5 GHz	53.0	59		dB
	300 kHz–1.0 GHz	45.0	48		dB
	300 kHz–2.5 GHz	29.5	30		dB
Return loss	300 kHz–0.5 GHz	15.8	21		dB
	300 kHz–1.0 GHz	12.7	16		dB
	300 kHz–2.5 GHz	10.9	13		dB
Return loss J2 port (ISO state)	300 kHz–0.5 GHz	15.8	22		dB
	300 kHz–1.0 GHz	12.7	18		dB
	300 kHz–2.5 GHz	10.1	11.5		dB

Operating Characteristics

$V_{CTL} = 0\text{ V}/-5\text{ V}$, $T = 25\text{ }^\circ\text{C}$, $P_{INPUT} = 0\text{ dBm}$, $Z_0 = 50\text{ }\Omega$, unless otherwise noted

Parameter	Condition	Frequency	Min.	Typ.	Max.	Unit
Switching Characteristics	10% RF envelope to 90% RF envelope			5		ns
	90% RF envelope to 10% RF envelope					ns
	50% V_{CTL} to 90% RF envelope			15		ns
	50% V_{CTL} to 10% RF envelope					ns
Input power for 1dB compression		0.05 GHz		16		dBm
		0.5 GHz–2 GHz		24		dBm
Intermodulation intercept point (IP3)	Two tone input power = 13 dBm per tone 1 MHz spacing	0.05 GHz		35		dBm
		0.5 GHz–2 GHz		46		dBm
Control voltages	V_{CTL} Low		-0.2		0	V
	V_{CTL} High		-3		-5	V
Control currents	V_{CTL} Low, V_{CTL} High			5	20	μA

Typical Performance Data (0, -5 V)

$Z_0 = 50\text{ }\Omega$, unless otherwise noted

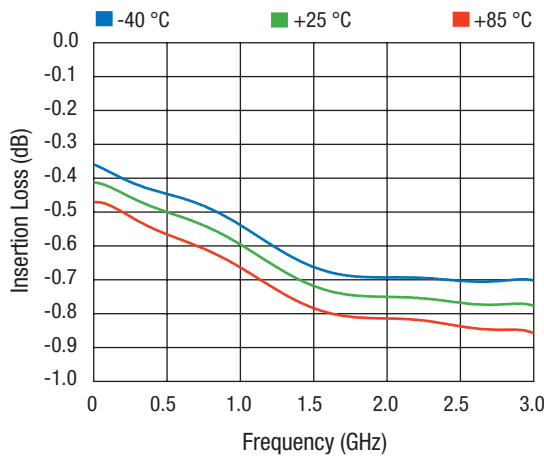

Typical Insertion Loss

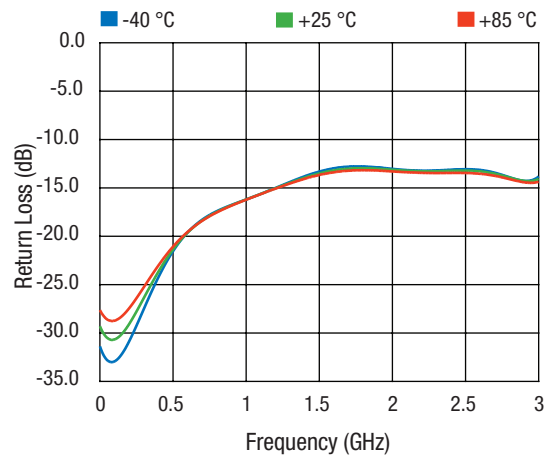

Typical J1 Return Loss (Insertion Loss State)

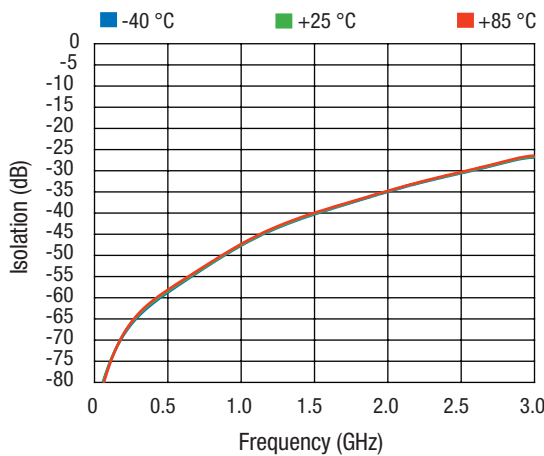

Typical Isolation

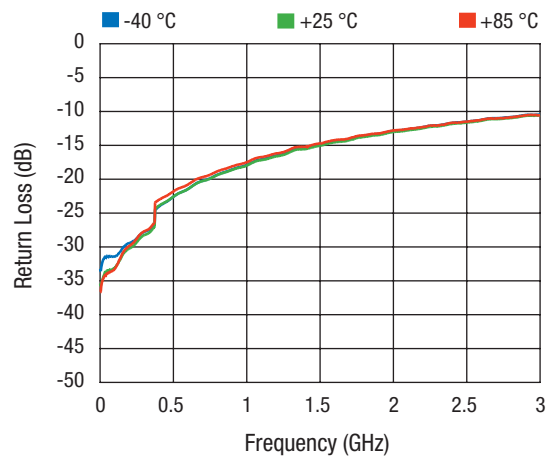

Typical J2 Return Loss (Isolation State)

Absolute Maximum Ratings

Characteristic	Value
RF input power	30 dBm > 500 MHz 0/-5 V 27 dBm at 50 MHz 0/-5 V
Control voltage	+0.2 V, -8 V
Operating temperature	-40 °C to +85 °C
Storage temperature	-65 °C to +150 °C

Performance is guaranteed only under the conditions listed in the specifications table and is not guaranteed under the full range(s) described by the Absolute Maximum specifications. Exceeding any of the absolute maximum/minimum specifications may result in permanent damage to the device and will void the warranty.

CAUTION: Although this device is designed to be as robust as possible, ESD (Electrostatic Discharge) can damage this device. This device must be protected at all times from ESD. Static charges may easily produce potentials of several kilovolts on the human body or equipment, which can discharge without detection. Industry-standard ESD precautions must be employed at all times.

Truth Table

V1	V2	J1-J2
-5	0	Insertion loss
0	-5	Isolation

Any state other than described in the truth table will put the switch in an undefined state.

Package Outline

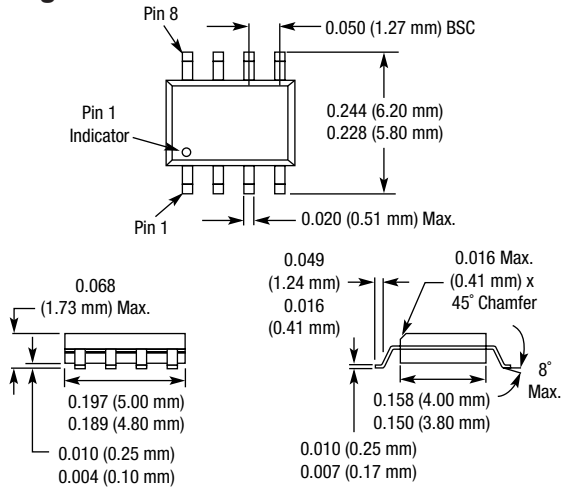

Pin Out

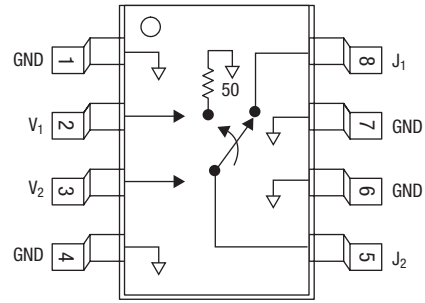

Pin Descriptions

Pin Number	Pin Name	Description
1	GND	Ground
2	V1	DC control voltage
3	V2	DC control voltage
4	GND	Ground
5	J2	RF port
6	GND	Ground
7	GND	Ground
8	J1	RF port

Copyright © 2008, Skyworks Solutions, Inc. All Rights Reserved.

Information in this document is provided in connection with Skyworks Solutions, Inc. ("Skyworks") products or services. These materials, including the information contained herein, are provided by Skyworks as a service to its customers and may be used for informational purposes only by the customer. Skyworks assumes no responsibility for errors or omissions in these materials or the information contained herein. Skyworks may change its documentation, products, services, specifications or product descriptions at any time, without notice. Skyworks makes no commitment to update the materials or information and shall have no responsibility whatsoever for conflicts, incompatibilities, or other difficulties arising from any future changes.

No license, whether express, implied, by estoppel or otherwise, is granted to any intellectual property rights by this document. Skyworks assumes no liability for any materials, products or information provided hereunder, including the sale, distribution, reproduction or use of Skyworks products, information or materials, except as may be provided in Skyworks Terms and Conditions of Sale.

THE MATERIALS, PRODUCTS AND INFORMATION ARE PROVIDED "AS IS" WITHOUT WARRANTY OF ANY KIND, WHETHER EXPRESS, IMPLIED, STATUTORY, OR OTHERWISE, INCLUDING FITNESS FOR A PARTICULAR PURPOSE OR USE, MERCHANTABILITY, PERFORMANCE, QUALITY OR NON-INFRINGEMENT OF ANY INTELLECTUAL PROPERTY RIGHT; ALL SUCH WARRANTIES ARE HEREBY EXPRESSLY DISCLAIMED. SKYWORKS DOES NOT WARRANT THE ACCURACY OR COMPLETENESS OF THE INFORMATION, TEXT, GRAPHICS OR OTHER ITEMS CONTAINED WITHIN THESE MATERIALS. SKYWORKS SHALL NOT BE LIABLE FOR ANY DAMAGES, INCLUDING BUT NOT LIMITED TO ANY SPECIAL, INDIRECT, INCIDENTAL, STATUTORY, OR CONSEQUENTIAL DAMAGES, INCLUDING WITHOUT LIMITATION, LOST REVENUES OR LOST PROFITS THAT MAY RESULT FROM THE USE OF THE MATERIALS OR INFORMATION, WHETHER OR NOT THE RECIPIENT OF MATERIALS HAS BEEN ADVISED OF THE POSSIBILITY OF SUCH DAMAGE.

Skyworks products are not intended for use in medical, lifesaving or life-sustaining applications, or other equipment in which the failure of the Skyworks products could lead to personal injury, death, physical or environmental damage. Skyworks customers using or selling Skyworks products for use in such applications do so at their own risk and agree to fully indemnify Skyworks for any damages resulting from such improper use or sale.

Customers are responsible for their products and applications using Skyworks products, which may deviate from published specifications as a result of design defects, errors, or operation of products outside of published parameters or design specifications. Customers should include design and operating safeguards to minimize these and other risks. Skyworks assumes no liability for applications assistance, customer product design, or damage to any equipment resulting from the use of Skyworks products outside of stated published specifications or parameters.

Skyworks, the Skyworks symbol, and "Breakthrough Simplicity" are trademarks or registered trademarks of Skyworks Solutions, Inc., in the United States and other countries. Third-party brands and names are for identification purposes only, and are the property of their respective owners. Additional information, including relevant terms and conditions, posted at www.skyworksinc.com, are incorporated by reference.