

Dupline Car Park System

Type GP62x0 22xx 724-US

Ultrasonic Sensor

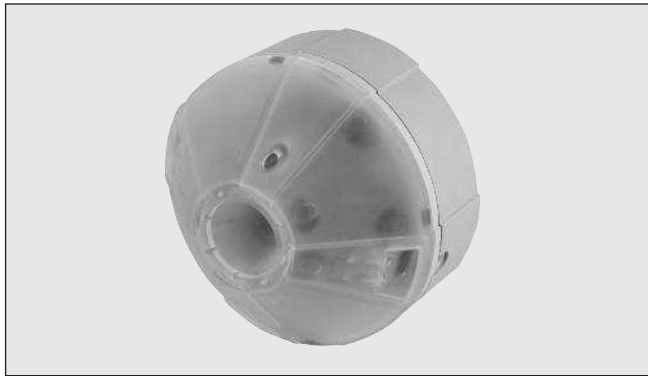

- Ultrasonic sensor for detection of cars
- Low current consumption
- Self-calibration of the sensor can be performed globally on all sensors at once or locally on a single sensor
- Wide measuring range
- Protected against dust and moisture
- Dupline 3-wire bus system with power
- Address coding with Carpark Configurator GP73800080
- GP6220 2201 724-US has built in green/red LED indicator
- GP6220 2202 724-US has built in blue/red LED indicator
- GP6240 2224 724-US has no LED built in. The sensor is design to be used together with the passive LED indicator GP6289 000x-US
- cULus approved

Product Description

The ultrasonic sensor is part of the car park system which contains other variants of sensors, monitors and displays. The GP62x0 22xx 724-US sensor is installed in the middle of the ceiling above the parking bay and detects whether a car is parked in the bay. The parking bay status is indicated using the built in LEDs, for GP6220 2201 724-US or GP6220 2202 724-US. The GP6240 2224 724-US has not built in LED, but uses the passive LED indicators GP6289 000x-US to show the status.

E.g. green LED indicates that the parking bay is available for parking. A red LED indicates that the parking bay is occupied or booked. Each sensor need to be connected to the Dupline 3-wire bus. The bus provides power and enables the sensors to transmit the status of the parking bays to the carpark monitoring devices (GP3482 9091 724), which keep track of the number of free parking bays in an area and show the result on the connected displays.

Ordering key

GP 62x0 22xx 724-US

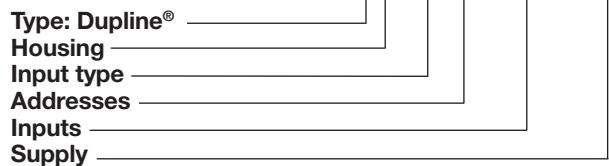

Type Selection

GP6220 2201 724-US	Sensor with green/red LED
GP6220 2202 724-US	Sensor with blue/red LED
GP6240 2224 724-US	Sensor without LED

Input/Output Specifications

RJ12 connector	for address programming with Carpark Configurator GP7380 0080
2x3-pin connector	<ul style="list-style-type: none"> • Printed dot on the sensor is Dupline® + • D- or Gnd • POW (power from DMM or Coupler). See drawing on page 3 (System diagram)
1x2-pin connector	Not in use for Carpark sensors GP6220 220x 724-US. Only in use for GP6240 2224 724-US and the passive LED indicator GP6289 000x-US. See drawing example on page 5

NOTE: The sensor connectors are using the “push-wire connection” methode. Use 1.5 mm² single core wire for the sensor installation.

Supply Specifications

Power supply:	21 VDC min.; 30 VDC max. (Overvoltage category III (IEC60664))
Consumption on the Dupline bus	0.03 mA
Max. supply current	
GP6220 220x 724-US	20 mA
GP6240 2224 724-US	15 mA
Nominel Supply	28 VDC / 19 mA 0,53 W

General Specifications

Ultrasonic frequency	40 kHz	The sensor uses 2 Dupline® addresses	
Max. distance between ceiling and floor	4.0 m		
Min. distance between ceiling and floor	1.5 m	• Status address	Indicates the status of the sensor. Default Dupline® address is A2
Min. calibration distance	1.5 m	• Calibration address	For common sensor calibration. Default Dupline® address is P1
Hysteresis	±30 cm	Programming unit	GP7380 0080
Sensor in “Normal” mode Sensor activations time	3 sec. See fig. 1 (Default)	Approval	cULus (UL60950)
Sensor in “Lane” mode Sensor activations time	0.4 sec. with a max car speed on 20 km/hour. See fig. 2		
LED indication: GP62202201 724-US Occupied: Bay available:	Red LED continuously lit Green LED continuously lit		
GP62202202 724-US Occupied: Bay available:	Red LED continuously lit Blue LED continuously lit		
GP62402224 724-US	No LED		

Mode of Operation

The ceramic sensor emits an acoustic signal at a frequency of 40 kHz which is reflected when it hits the floor and returned to the sensor. The reflected signal indicates whether the parking bay is available or occupied.

Sensor addresses

• Status Dupline® address
The Dupline bus address used by the sensor to transmit the status of the parking bay. The same address can be used to force the red LED ON** for booking of free parking bays (this feature requires management by central PC software). Please refer to the Dupline Carpark system manual for further information about the Dupline addressing scheme and the rules that apply for the assignment.

• Calibration Dupline® address

This address is used to trigger the sensor to perform a self calibration. Several sensors can be given the same calibration address, thereby making it possible to calibrate multiple sensors at once by sending a single trigger signal on that address. The programming unit GP73800080 is used to send out the trigger signal.

Modes

The sensor has two modes. Normal mode or Lane mode.

In **Normal mode**, the sensor detects the presence of a car in the parking bay and lights the red LED**. See fig. 1 on page 4. At the same time the sensor sends a signal out on the Dupline® 3-wire bus.

When the parking bay is empty the LED will change to green** and also send a signal out on the Dupline® 3-wire bus.

The sensor will not react to objects lower than 0,3 m. To avoid a weak signal, the sensor must be installed pointing directly at a hard surface, as for instance concrete. A soft or uneven surface will reduce the signal.

In **Lane mode**, the sensor is designed to be mounted in the ceiling above the lane. The sensor is able to detect moving cars with a maximum speed of 20 km/hour. See fig. 2 on page 4.

When the sensor detects a moving car it sends a signal to the Carpark system that count down the total amount of free places, and show the

reduced amount on the local display but also on the display that show the total amount of free places. This is to prevent to many moving cars in a specific carpark area. The sensor does not show the actual status on the LED's. The LED's** only works as feedback during calibration, start-up and show the fail status.

** GP6240 2224 724-US uses the passive LED indicator GP6289 000x-US

The sensor is designed to work in an area which is:

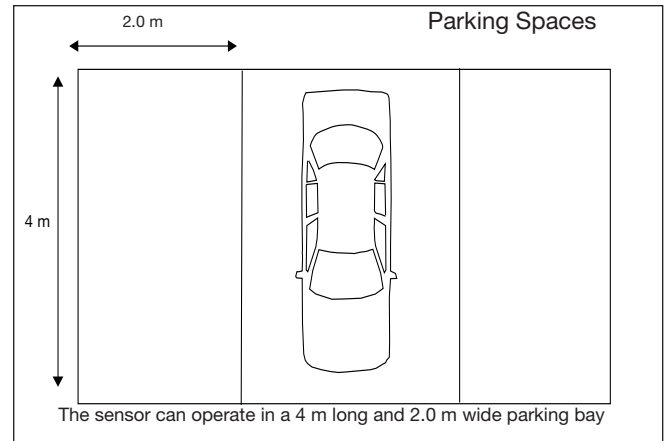
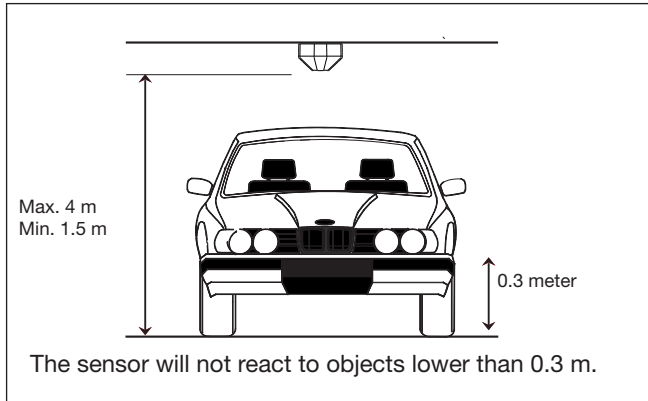

The sensor should be placed freely, e.g. in the following way:

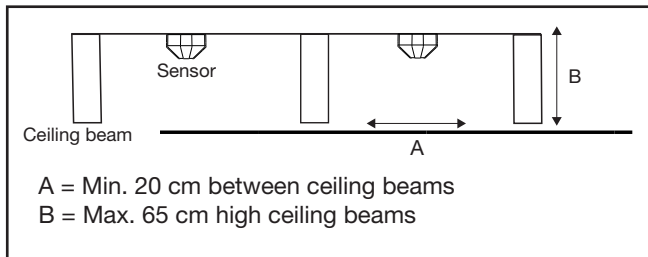

Mounting sensor

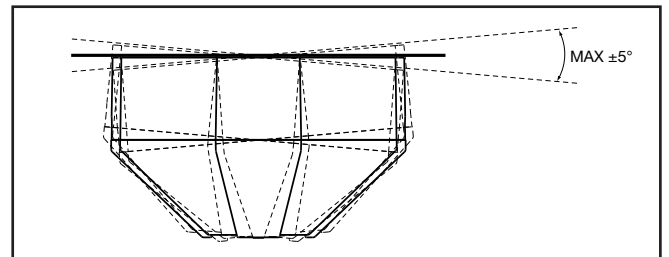

To receive the best signal, the sensor must be installed with an angle on the ceiling on maximum $\pm 5^\circ$.

Calibration

Note:

The calibration procedure is equal on all sensor types. The GP6240 2224 724-US does not have built-in LED indication but uses a passive LED indicator. This explanation describe a standard calibration procedure.

The sensor is self-calibrating. It is important to perform the calibration when the parking bay is empty.

There are two ways of calibrating a sensor .

Manual calibration is a local calibration of the single sensor.

- Push the button on the out side of the sensor.
- The LED flashes green for 30 seconds with 1 Hz. (The electrician has time to get clear of the sensor before the calibration starts).
- The calibration starts when the LED flashes green for 6 seconds with 4 Hz.
- If the calibration is OK, the LED will respond with a constant green light.

Error messages:

- If the calibration fails, the LED will respond with a constant flashing red light. If the LED flashes red, the sensor could be out of range or the sensor is not aligned correctly.
- Adjust the sensor into the sensing area and recalibrate the sensor.
- If Dupline® is not connected/defect the LED will flash red.
- If Dupline® is short circuit the LED will flash red.
- Sensor first time start up. The sensor LED will flash red because it's needs calibration.

Automatic calibration with the Carpark Configurator GP 7380 0080 is a global calibration of all connected sensors. The parking bay must be empty during the calibration process.

Environment

- Protection: IP 34
- Operating temperature: -40°C to 70°C (-40°F to 158°F)
- Storage temperature: -40°C to 85°C (-40°F to 185°F)
- Pollution Degree: 3 (IEC 60664)
- Dimensions: Ø118 x 76 mm
- Material: The case is made of polypropylene. The sensor lid is made of clear Polycarbonate.

Dimensions

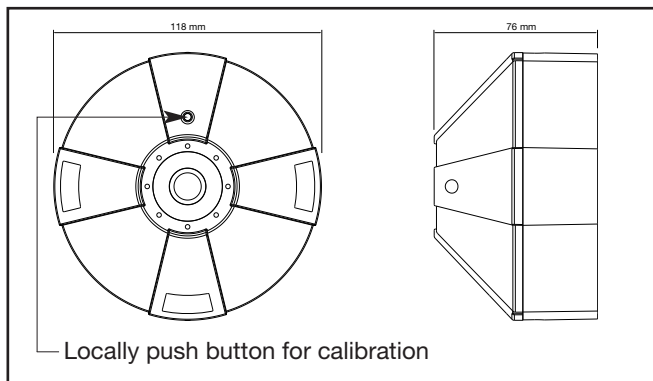

System Diagram

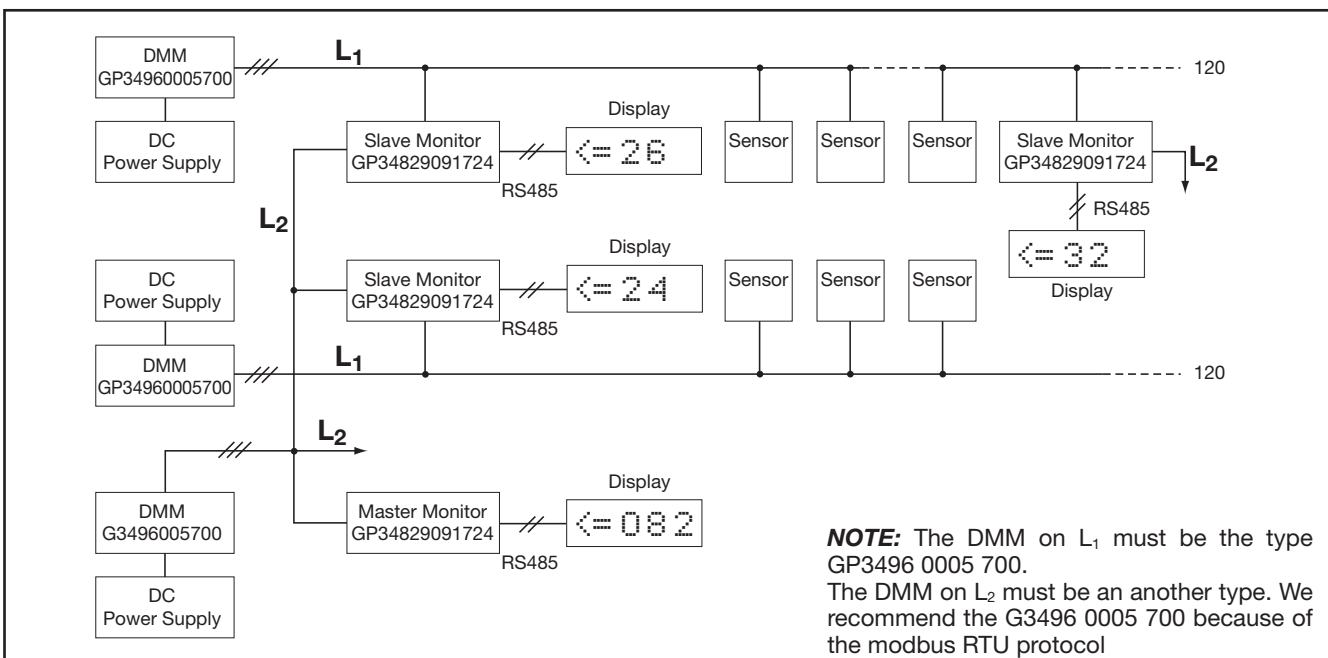
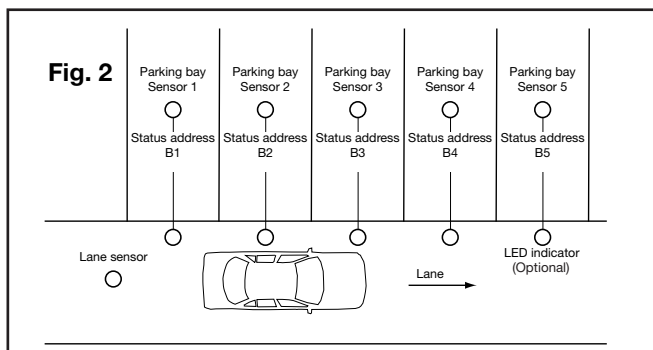
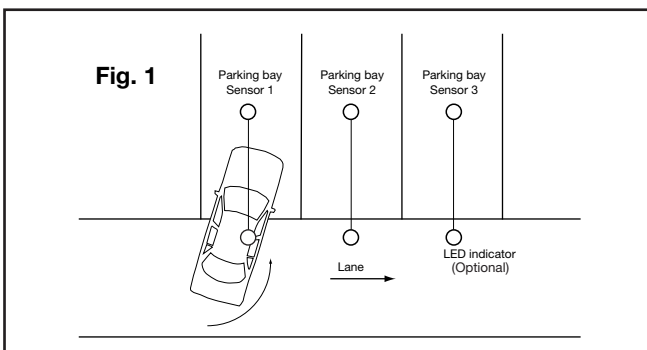
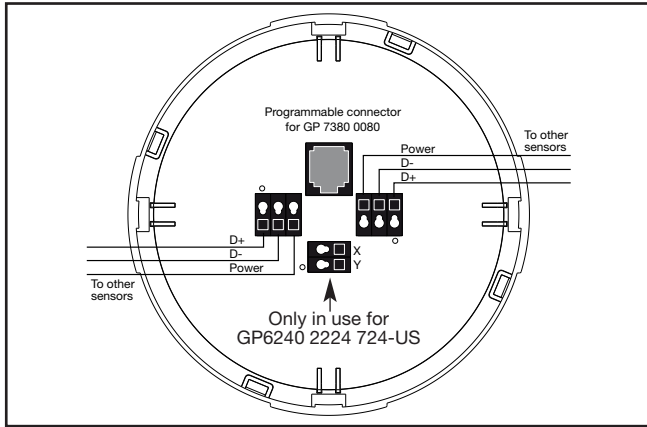

Fig. 1 and Fig. 2



The sensors can be used as both parking bay (Normal mode) and lane sensors (Lane mode).
See the manual on how to program the sensors.
The sensors are basically equal to each other.
It is only the programming that makes them different from each other.
The GP6240 2224 724-US does not have a built-in LED.

Wiring Diagram



Bottom part: mounted in ceiling

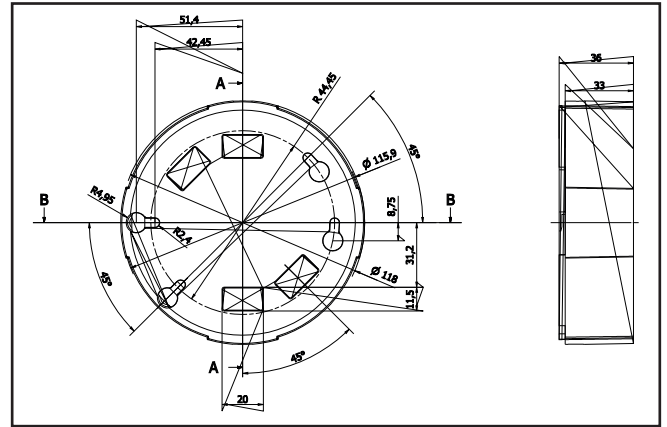

Note: The 2 x 3 pin connector are internally connected on the PCB.

Note: X and Y is not in use for model number GP6220 2201 724-US and GP6220 2202 724-US

NOTE: The wiring of the sensors must always be made with 1.5 mm² single core wire

Connection diagram

