

# Cup Anemometer PVC Housing, Rotor of black painted Stainless Steel Type DWS-V-DAC13



- Anemometer with opto-electronic detection
- Measuring range: 2 to 30 m/s
- PNP and NPN open collector outputs in the same unit
- Current source outputs
- 10 to 28 VDC supply voltage
- All inputs and outputs are protected against reverse polarity and transients
- High ESD protection
- Built-in heater
- Dust sealing

## Product Description

DWS-V-DAC13 is a cup anemometer designed for measuring air speed in a wide variety of applications, including wind turbines, buildings, cranes, weather stations, green-houses, etc. The product contains both PNP- and NPN open collector outputs, in which a fixed current is switched proportionally to the air speed at the rate of 10 pulses per m/s. A built-in self-regulated heater reduces the risk of

glazing. The heater is supplied separately, which makes it possible to control the heating. The DWS-V-DAC13 is equipped with a specially designed protection mechanism, which protects the bearings and the electronic parts against dirt and humidity. The body of the sensor is made of black PVC, and the rotor is produced in stainless steel.

## Ordering Key

**DWS-V-DAC13**

Type \_\_\_\_\_  
 Air velocity \_\_\_\_\_  
 Digital output \_\_\_\_\_  
 (Future subtypes) \_\_\_\_\_  
 Cable Version \_\_\_\_\_  
 Standard cable length in full metres<sup>1)</sup> \_\_\_\_\_

<sup>1)</sup> can be specified by customer

## Specifications

Rated operational voltage	U <sub>B</sub>	12 to 24 VDC
	U <sub>C</sub>	10 to 28 VDC
Supply current (without heater off)	Approx. 20 mA (all outputs off)	
Measuring range	1.5 to 30 m/s	
Accuracy	≤ 3 m/s: ±0.5 m/s ≥ 3 m/s: ±10%	

## Output Specifications

Signal output	NPN Open Collector constant current sink	Square wave 12.5 mA ± 2mA
	PNP Open Collector constant current source	
Output frequency	10 Hz per m/s	
Output power	≤ 250 mW	
Load supply voltage	Min.	10 VDC
	Max.	28 VDC
Voltage drop	Typ. 4.9 VDC	

## General Specifications

Dimensions	Rotor diameter	145 mm
	Thread	External thread: M28 x 2 with one nut
Materials	Body	Black PVC
	Rotor	Stainless steel (AISI 303), black painted
	Bearings	Instrument ball bearings, stainless steel
Cable	13 m shielded grey PVC, 6 x 0.25 mm <sup>2</sup>	
Rotor/housing tightening	Dust labyrinth	
Environment	Degree of protection	IP54
	Ambient humidity	0 to 100% RH
	Climatic protection	Against high humidity, salt and dust
Ambient temperature	Operating temperature	-20 to 60°C (-4 to +140°F)
	Storage temperature	-20 to 60°C (-4 to +140°F)
Heating system	Heater	> -20°C (> -4°F)
	Supply voltage	PTC-element 12 to 24 VAC/DC on separate wires

## General Specifications (cont.)

Inrush current	1.5 A	IEC 61000-4-5 Surge 1.2/50 $\mu$ s Power port, $R_i = 2 \Omega$ Signal port, $R_i = 47 \Omega$	500 V 2000 V
Power consumption	@ -20°C (-4°F): app. 10 W @ +20°C (+68°F): app. 5 W @ +60°C (+140°F): app. 1.5 W		
<b>EMC</b>		IEC 61000-4-6 Conducted disturbances induced by radio-frequency fields	12 V <sub>rms</sub>
IEC 61000-4-2 Contact discharge	$\pm 4$ kV	<b>Mounting position</b>	Vertical with M28 thread
Air discharge	$\pm 8$ kV		
IEC 61000-4-3 Radiated radio-frequency Electromagnetic fields	15 V/m	<b>Weight</b>	1.1 kg incl. 13 m cable and packaging
IEC 61000-4-4 Fast transients/burst			
Power port, performance B $\pm$ 2 kV			
Signal port, performance B	$\pm 1$ kV		

## Dimensions

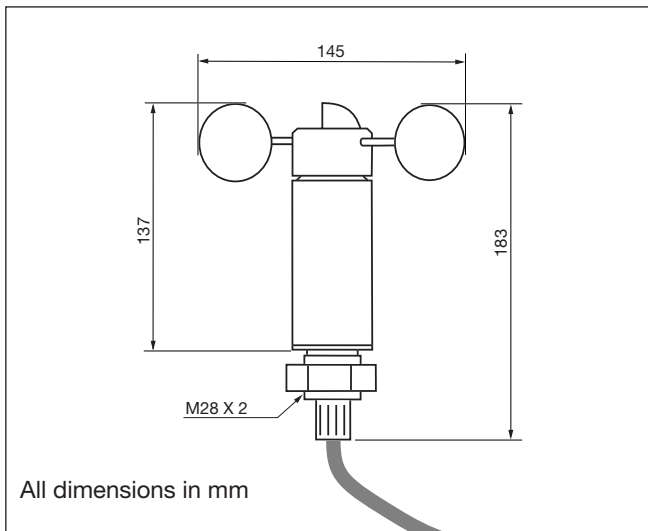

## Wiring Diagram

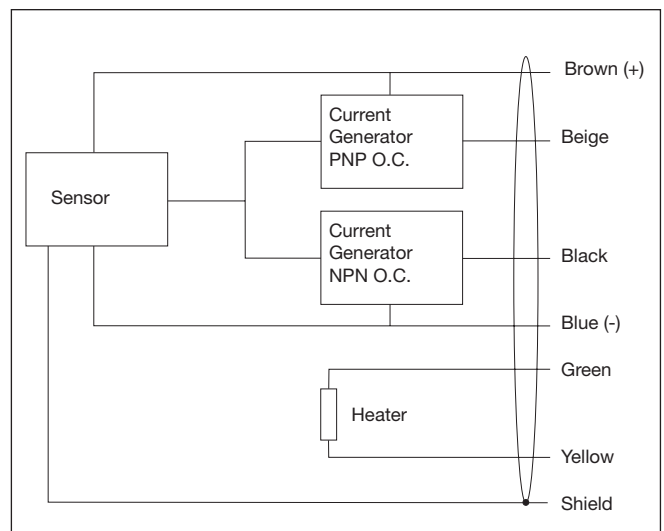

## PV output versus wind speed

