

**Description:**

The ZVL Series of low voltage leaded multilayer varistors (MLVs) is designed to protect sensitive electronic devices operating in the low voltage region against high voltage / current surges. They offer excellent transient energy absorption due to improved energy volume distribution and power dissipation. Low voltage MLVs cover a wide DC operating voltage range from 3 to 56V.



**Features:**

- AC operating voltage (Vrms) from 2V to 40V
- DC operating voltage (Vdc) from 3V to 56V
- 5 model sizes available 05, 07, 10, 14, 20
- Available with straight or crimped leads
- Broad range of current and energy handling capabilities
- +125°C continuous operating temperature (+150°C for ZVYL)
- Dimensional and weight savings on PC board
- Bi-directional, lower clamping voltages than disc type varistors
- ZVYL high temperature product will have performance characteristics different from the ZVL.  
Contact Factory for specific details.

**Applications:**

- Suppression of inductive switching or other transient events at the circuit board level
- Provides on-board transient voltage protection for ICs and transistors
- Used to help achieve electromagnetic compliance of end products
- Replace larger TVS Zener diodes in many applications

**How to Order**

SEI Type		Lead Style		Vrms	Tolerance		Model Size	Packaging	
ZV		1		14	K		10	R	
Type	Description	Model Size	Version	Code	Tolerance	Size (mm)	Code	Description	
ZVL	Standard	05, 07, 10	1 = Outward Crimped Leads	K	10%	05	B	Bulk	
ZVYL	High Temp	14	1 = Straight Leads	L	15%	07	T	Tape and Reel	
		14	5 = Straight Leads, Kinked	M	20%	10	A	Ammo Pack	
		20	1 = Inward Crimped Leads			14			
						20			

New part number format starting January 3<sup>rd</sup>, 2011:

**How to Order**

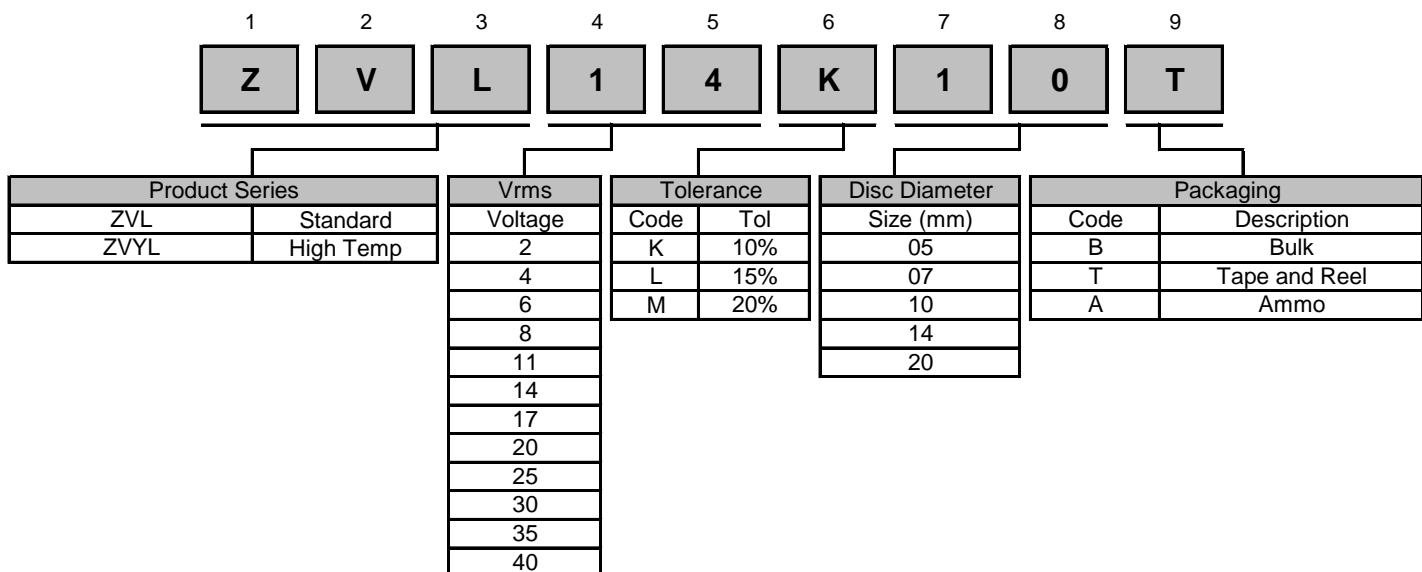

General Technical Data		
Operating Temperature - ZVL	-40°C to +125°C	In accordance with CECC 42 000
Operating Temperature - ZVYL	-40°C to +150°C	
Storage Temperature Range	-40°C to +150°C	
Threshold Voltage Temperature Coefficient	< -0.05% / °C	
Insulation Resistance	> 1Gohm	
Isolation Voltage Capability	> 1kV	
Response Time	< 25 nS	

Standard Packaging Options / Quantities					
Series	Voltage Range (Vrms)	Model Size	Packaging options 7mm, 10mm, 14mm, 20mm and 23mm		
			B (Bulk)	R (Reel)	A (Ammo Pack)
ZVL, ZVYL	2 - 40	05	2,000	2,000	2,000
	2 - 40	07	1,500	2,000	2,000
	2 - 40	10	1,000	1,500	1,000
	2 - 40	14	700	1,500	1,000
	2 - 40	20	500	1,500	800

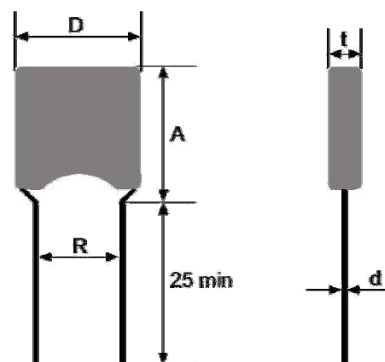

Device Ratings and Dimensions														
Part Number ZVL/ZVYL	V <sub>RMS</sub> (volts)	V <sub>DC</sub> (volts)	V <sub>N</sub> (volts)	V <sub>C</sub> (volts)	I <sub>C</sub> (amps)	W <sub>MAX</sub> (joules)	P <sub>MAX</sub> (watts)	I <sub>MAX</sub> (amps)	C <sub>TYP</sub> (pF)	D <sub>MAX</sub> (nH)	t <sub>MAX</sub> (mm)	R (mm)	d (mm)	h/A <sub>MAX</sub> (mm)
ZVL2M05	2	3	4	10	1	0.10	0.005	100	1,300	6.0	3.50	5	0.6	7
ZVL2M07	2	3	4	10	2.5	0.20	0.008	200	5,000	7.0	3.50	5	0.6	8
ZVL4M05	4	5.5	8	14	1	0.10	0.005	100	1,066	6.0	3.50	5	0.6	7
ZVL4M07	4	5.5	8	14	2.5	0.30	0.008	200	3,720	7.0	3.50	5	0.6	8
ZVL4M10	4	5.5	8	14	5	0.40	0.010	300	5,000	7.0	3.50	5	0.6	9
ZVL4M14	4	5.5	8	14	10	0.80	0.015	500	10,000	8.0	3.50	5	0.6	12
ZVL4M20	4	5.5	8	14	20	1.50	0.020	1,000	17,000	9.0	3.50	5	0.6	12
ZVL6M05	6	8	11	21	1	0.20	0.005	100	831	6.0	3.50	5	0.6	7
ZVL6M07	6	8	11	21	2.5	0.50	0.008	200	2,770	7.0	3.50	5	0.6	8
ZVL6M10	6	8	11	21	5	0.80	0.010	300	4,070	7.0	3.50	5	0.6	9
ZVL6M14	6	8	11	21	10	1.00	0.015	500	7,630	8.0	3.50	5	0.6	12
ZVL6M20	6	8	11	21	20	3.80	0.020	1,000	13,400	9.0	3.50	5	0.6	12

Ratings and Dimensions														
Part Number ZVL/ZVYL	V <sub>RMS</sub> (volts)	V <sub>DC</sub> (volts)	V <sub>N</sub> (volts)	V <sub>C</sub> (volts)	I <sub>C</sub> (amps)	W <sub>MAX</sub> (joules)	P <sub>MAX</sub> (watts)	I <sub>MAX</sub> (amps)	C <sub>TYP</sub> (pF)	D <sub>MAX</sub> (nH)	t <sub>MAX</sub> (mm)	R (mm)	d (mm)	h/A <sub>MAX</sub> (mm)
ZVL8L05	8	11	15	25	1	0.20	0.005	100	650	6.0	3.50	5	0.6	7
ZVL8L07	8	11	15	25	2.5	0.60	0.008	250	2,020	7.0	3.50	5	0.6	8
ZVL8L10	8	11	15	25	5	1.10	0.010	500	3,200	7.0	3.50	5	0.6	9
ZVL8L14	8	11	15	25	10	1.90	0.015	800	6,260	8.0	3.50	5	0.6	12
ZVL8L20	8	11	15	25	20	4.30	0.020	1,500	11,070	9.0	3.50	5	0.6	12
ZVL11K05	11	14	18	33	1	0.30	0.005	100	480	6.0	3.50	5	0.6	7
ZVL11K07	11	14	18	33	2.5	0.80	0.008	250	1,400	7.0	3.50	5	0.6	8
ZVL11K10	11	14	18	33	5	1.70	0.010	500	2,420	7.0	3.50	5	0.6	9
ZVL11K14	11	14	18	33	10	3.30	0.015	1,000	5,000	8.0	3.50	5	0.6	12
ZVL11K20	11	14	18	33	20	10.50	0.020	2,000	9,270	9.0	3.50	5	0.6	12
ZVL14K05	14	18	22	38	1	0.40	0.005	100	377	6.0	3.50	5	0.6	7
ZVL14K07	14	18	22	38	2.5	0.90	0.008	250	1,050	7.0	3.50	5	0.6	8
ZVL14K10	14	18	22	38	5	2.20	0.010	500	1,770	7.0	3.50	5	0.6	9
ZVL14K14	14	18	22	38	10	4.20	0.015	1,000	3,850	8.0	3.50	5	0.6	12
ZVL14K20	14	18	22	38	20	12.00	0.020	2,000	7,670	9.0	3.50	5	0.6	12
ZVL17K05	17	22	27	44	1	0.50	0.005	100	335	6.0	3.50	5	0.6	7
ZVL17K07	17	22	27	44	2.5	1.20	0.008	250	850	7.0	3.50	5	0.6	8
ZVL17K10	17	22	27	44	5	2.60	0.010	500	1,370	7.0	3.50	5	0.6	9
ZVL17K14	17	22	27	44	10	5.20	0.015	1,000	3,050	8.0	3.50	5	0.6	12
ZVL17K20	17	22	27	44	20	14.20	0.020	2,000	6,600	9.0	3.50	5	0.6	12
ZVL20K05	20	26	33	54	1	0.60	0.005	100	325	6.0	4.50	5	0.6	7
ZVL20K07	20	26	33	54	2.5	1.40	0.008	250	790	7.0	4.50	5	0.6	8
ZVL20K10	20	26	33	54	5	3.20	0.010	500	1,090	7.0	4.50	5	0.6	9
ZVL20K14	20	26	33	54	10	6.40	0.015	1,000	2,490	8.0	4.50	5	0.6	12
ZVL20K20	20	26	33	54	20	18.20	0.020	2,000	5,670	9.0	4.50	5	0.6	12
ZVL25K05	25	31	39	65	1	0.70	0.005	100	315	6.0	4.50	5	0.6	7
ZVL25K07	25	31	39	65	2.5	1.60	0.008	250	790	7.0	4.50	5	0.6	8
ZVL25K10	25	31	39	65	5	3.80	0.010	500	870	7.0	4.50	5	0.6	9
ZVL25K14	25	31	39	65	10	7.20	0.015	1,000	1,890	8.0	4.50	5	0.6	12
ZVL25K20	25	31	39	65	20	22.40	0.020	2,000	4,670	9.0	4.50	5	0.6	12
ZVL30K05	30	38	47	77	1	0.90	0.005	100	315	6.0	4.50	5	0.6	7
ZVL30K07	30	38	47	77	2.5	2.20	0.008	250	790	7.0	4.50	5	0.6	8
ZVL30K10	30	38	47	77	5	4.40	0.010	500	770	7.0	4.50	5	0.6	9
ZVL30K14	30	38	47	77	10	9.40	0.015	1,000	1,530	8.0	4.50	5	0.6	12
ZVL30K20	30	38	47	77	20	25.80	0.020	2,000	3,870	9.0	4.50	5	0.6	12
ZVL35K05	35	45	56	90	1	1.20	0.005	100	315	6.0	4.50	5	0.6	7
ZVL35K07	35	45	56	90	2.5	2.60	0.008	250	790	7.0	4.50	5	0.6	8
ZVL35K10	35	45	56	90	5	5.40	0.010	500	680	7.0	4.50	5	0.6	9
ZVL35K14	35	45	56	90	10	10.20	0.015	1,000	1,260	8.0	4.50	5	0.6	12
ZVL35K20	35	45	56	90	20	33.40	0.020	2,000	3,470	9.0	4.50	5	0.6	12
ZVL40K05	40	56	68	110	1	1.40	0.005	100	315	6.0	4.50	5	0.6	7
ZVL40K07	40	56	68	110	2.5	3.20	0.008	250	790	7.0	4.50	5	0.6	8
ZVL40K10	40	56	68	110	5	6.40	0.010	500	660	7.0	4.50	5	0.6	9
ZVL40K14	40	56	68	110	10	13.40	0.015	1,000	1,070	8.0	4.50	5	0.6	12
ZVL40K20	40	56	68	110	20	37.80	0.020	2,000	3,130	9.0	4.50	5	0.6	12