

Splashproof Miniature Snap Action Switch E72-E73 Series

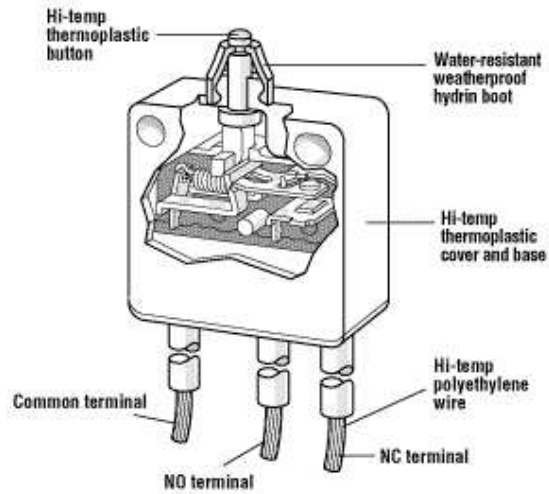

Features

- Moisture Resistant
- Long life coil spring mechanism
- Choice of button or hinged actuator
- 10", 16 gauge leads standard

Electrical Ratings and Operating Life		
Switch Series	According to UL1054	
	Nominal Load	Operation cycles
E72	10.1A 1/4HP 125/250 VAC	6000
E73	0.1A, 125 VAC	6000

Technical Specifications		Material Specifications	
Temperature Rating:	-40°C to +85°C	Case:	Hi-Temp Thermoplastic Nylon
Flammability Rating:	UL94V-0	Boot:	Hydrin
Wire:	10", 16 awg XLP (UL 3173) Ends stripped 0.150"	Actuator button:	Hi-Temp Thermoplastic Nylon
		Contacts:	E72 Silver Alloy E73 Gold Cross Point
		Actuator:	Stainless Steel
		Potting:	Polyamide
UL File Number:	E23301	Auxiliary actuator:	Stainless Steel

RoHS Compliant

Specifications subject to change without notice



Splashproof Miniature Snap Action Switch

E72-E73 Series

Dimensions inches

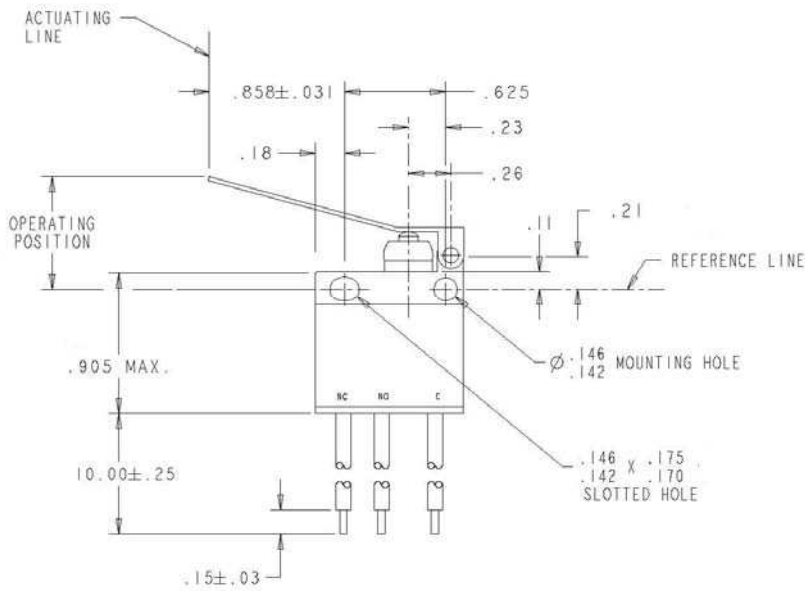

Hinge Screw Case

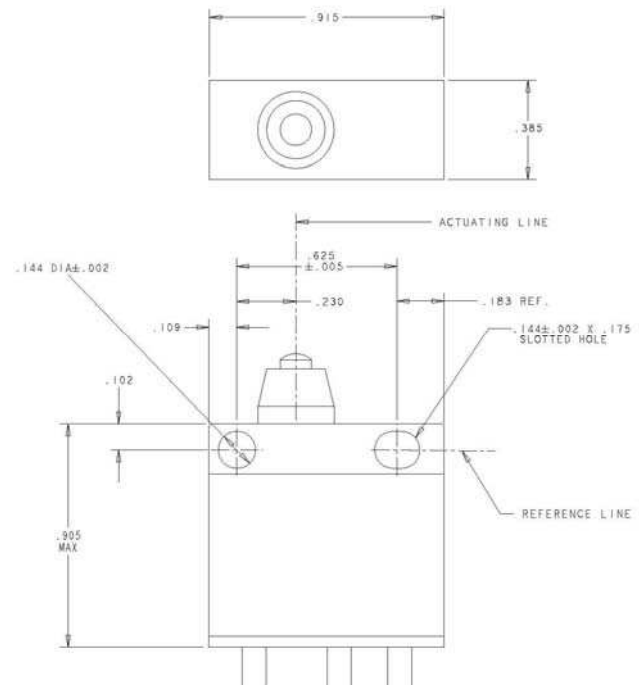

Screw Case

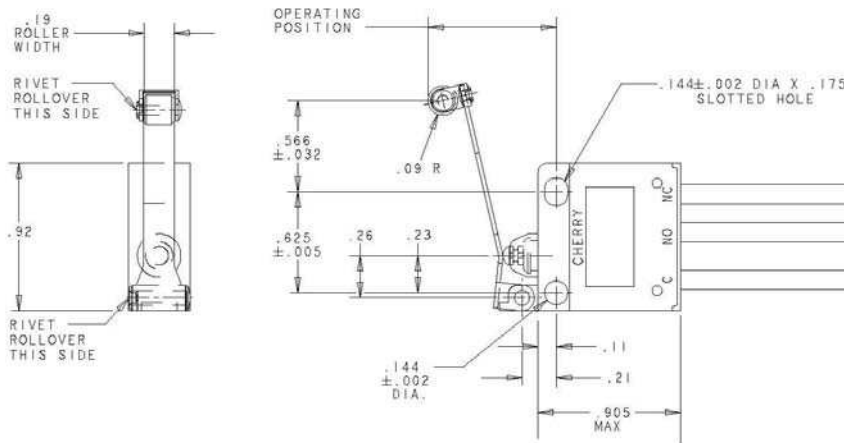

Commonly Stocked Distributor Items / Preferred Part Numbers

Part Number	Actuator Type	Maximum Operating Force (g)	Maximum Pre-travel inches (mm)	Operating Point inches (mm)	Minimum Overtravel inches (mm)	Maximum Movement Differential inches (mm)	Rest Position inches (mm)
0E7240AT	Button	300	0.040 (1.02)	.330 +/- .020 (8.38 +/- 0.51)	0.035 (0.89)	0.004 (0.10)	0.390 (9.91)
0E7240HT	Straight Lever	67	0.275 (6.99)	0.595 +/- 0.155 (15.13 +/- 3.94)	0.100 (2.54)	0.024 (0.61)	0.972 (24.69)
0E7240KT	Roller Lever	75	0.240 (6.10)	0.762 +/- 0.125 (19.35 +/- 3.18)	0.125 (3.18)	0.025 (0.635)	1.041 (26.44)

Specifications subject to change without notice

Contact

Call, fax or visit our Website for more information.

ZF Electronics Corporation
11200 88th Avenue
Pleasant Prairie, WI 53158

Phone: 262.942.6500
Web: www.cherrycorp.com
Email: cep_sales@zf.com
Fax: 262.942.6566

The manufacturer accepts no liability for errors or non-availability, and reserves the right to change specifications without prior notice.

Technical data relates to product specifications only. Features may differ from those described. Only drawings combined with product specifications shall be deemed binding.

© 2007 ZF Electronics Corporation

Last Updated: 04/27/11

