

Current Transducer LA 100-P/SP13

For the electronic measurement of currents: DC, AC, pulsed..., with galvanic isolation between the primary circuit (high power) and the secondary circuit (electronic circuit).

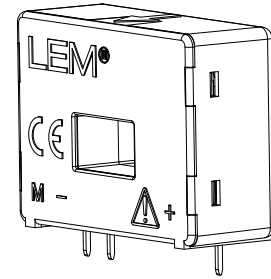

$I_{PN} = 100 \text{ A}$



Electrical data

I_{PN}	Primary nominal current rms	100	A
I_{PM}	Primary current, measuring range	0 .. ± 160	A
R_M	Measuring resistance		
	with $\pm 12 \text{ V}$	@ $\pm 100 \text{ A}_{\text{max}}$	$R_{M \text{ min}}$ 10 $R_{M \text{ max}}$ 65 Ω
		@ $\pm 160 \text{ A}_{\text{max}}$	10 30 Ω
	with $\pm 15 \text{ V}$	@ $\pm 100 \text{ A}_{\text{max}}$	40 95 Ω
		@ $\pm 160 \text{ A}_{\text{max}}$	40 50 Ω
I_{SN}	Secondary nominal current rms	100	mA
K_N	Conversion ratio	1 : 1000	
V_C	Supply voltage ($\pm 5 \%$)	$\pm 12 \dots 15$	V
I_C	Current consumption	10 (@ $\pm 15 \text{ V}$) + I_S	mA

Accuracy - Dynamic performance data

X	Accuracy @ $I_{PN}, T_A = 25^\circ\text{C}$	@ $\pm 15 \text{ V} (\pm 5 \%)$	± 0.45	%
		@ $\pm 12 \dots 15 \text{ V} (\pm 5 \%)$	± 0.70	
ϵ_L	Linearity error		< 0.15	%
I_O	Offset current @ $I_p = 0, T_A = 25^\circ\text{C}$		Typ ± 0.2 Max	mA
I_{OM}	Magnetic offset current ¹⁾ @ $I_p = 0$ and specified R_M , after an overload of $3 \times I_{PN}$		± 0.3	mA
I_{OT}	Temperature variation of I_O - $25^\circ\text{C} \dots +70^\circ\text{C}$		± 0.1 ± 0.5	mA
t_{ra}	Reaction time to 10 % of I_{PN} step		< 500	ns
t_r	Response time ²⁾ to 90 % of I_{PN} step		< 1	μs
di/dt	di/dt accurately followed		> 200	A/ μs
BW	Frequency bandwidth (-1 dB)		DC .. 200	kHz

General data

T_A	Ambient operating temperature	- 25 .. + 70	$^\circ\text{C}$
T_S	Ambient storage temperature	- 40 .. + 90	$^\circ\text{C}$
R_S	Secondary coil resistance @ $T_A = 70^\circ\text{C}$	25	Ω
m	Mass	18	g
	Standards	EN 50178: 1997	

Features

- Closed loop (compensated) current transducer using the Hall effect
- Printed circuit board mounting
- Insulated plastic case recognized according to UL 94-V0.

Special features

- $I_{PM} = 0 \dots \pm 160 \text{ A}$
- $K_N = 1 : 1000$
- $T_A = - 25^\circ\text{C} \dots + 70^\circ\text{C}$

Advantages

- Excellent accuracy
- Very good linearity
- Low temperature drift
- Optimized response time
- Wide frequency bandwidth
- No insertion losses
- High immunity to external interference
- Current overload capability.

Applications

- AC variable speed drives and servo motor drives
- Static converters for DC motor drives
- Battery supplied applications
- Uninterruptible Power Supplies (UPS)
- Switched Mode Power Supplies (SMPS)
- Power supplies for welding applications.

Application domain

- Industrial.

Notes: ¹⁾ Result of the coercive field of the magnetic circuit

²⁾ With a di/dt of 100 A/ μs .

Current Transducer LA 100-P/SP13

Isolation characteristics

V_d	Rms voltage for AC isolation test, 50 Hz, 1 min	2.5	kV
\hat{V}_w	Impulse withstand voltage 1.2/50 μ s	4.5	kV
		Min	
dCp	Creepage distance ¹⁾	3.8	mm
dCI	Clearance distance ²⁾	3.8	mm
CTI	Comparative Tracking Index (group IIIa)	175	

Applications examples

According to EN 50178 and IEC 61010-1 standards and following conditions:

- Over voltage category OV 3
- Pollution degree PD2
- Non-uniform field

	EN 50178	IEC 61010-1
dCp, dCI, \hat{V}_w	Rated isolation voltage	Nominal voltage
Single isolation	300 V	300 V
Reinforced isolation	150 V	150 V

Notes: ¹⁾ Distance between hole busbar and winding

²⁾ Direct distance between hole busbar and winding.

Safety



This transducer must be used in electric/electronic equipment with respect to applicable standards and safety requirements in accordance with the manufacturer's operating instructions.



Caution, risk of electrical shock

When operating the transducer, certain parts of the module can carry hazardous voltage (eg. primary busbar, power supply).

Ignoring this warning can lead to injury and/or cause serious damage.

This transducer is a build-in device, whose conducting parts must be inaccessible after installation.

A protective housing or additional shield could be used.

Main supply must be able to be disconnected.

Dimensions LA 100-P/SP13 (in mm. 1 mm = 0.0394 inch)

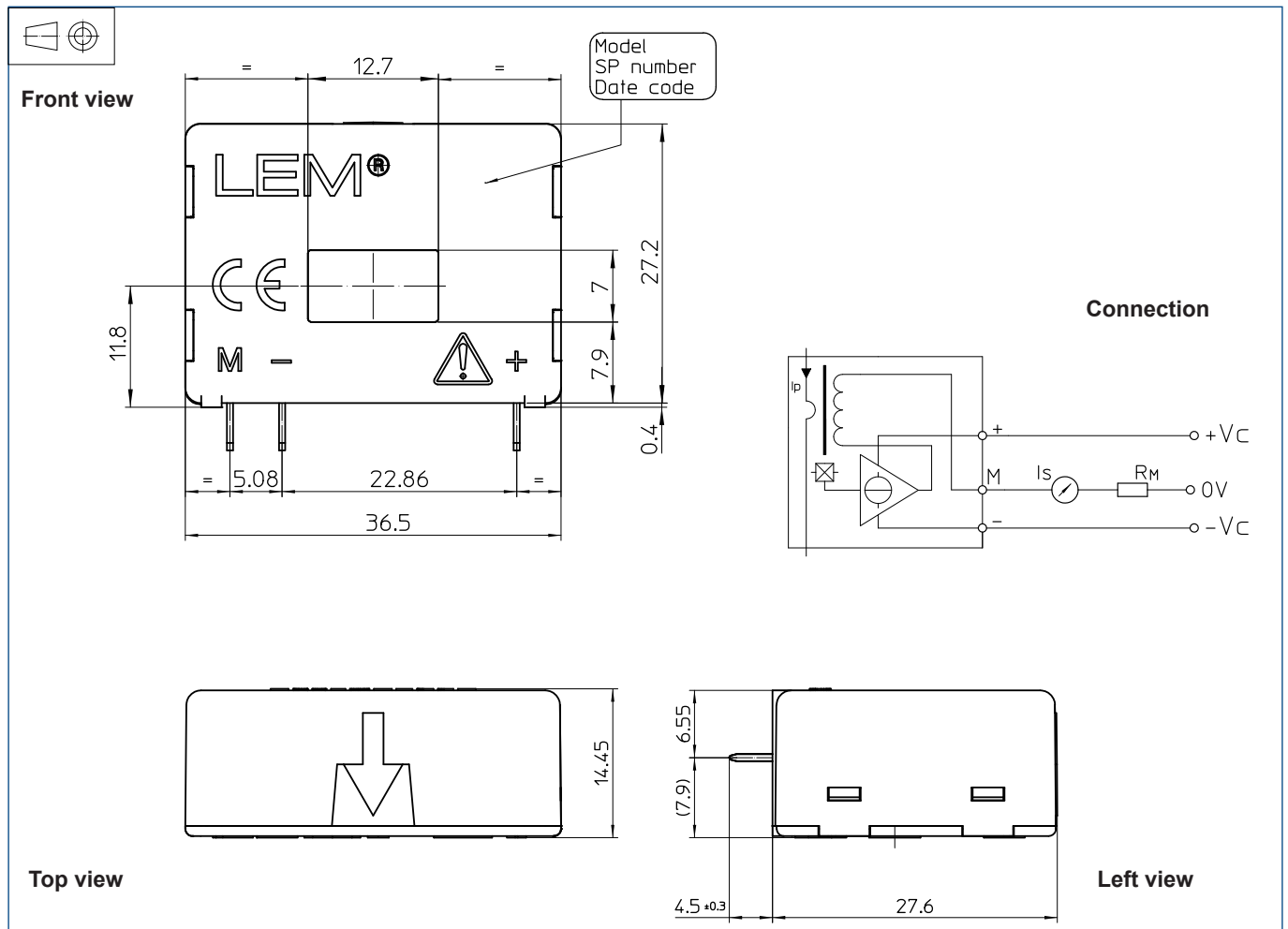

Mechanical characteristics

- General tolerance ± 0.2 mm
- Primary through-hole 12.7 x 7 mm
- Fastening & connection of secondary 3 pins
0.63 x 0.56 mm
- Recommended PCB hole 0.9 mm

Remarks

- I_s is positive when I_p flows in the direction of the arrow.
- Temperature of the primary conductor should not exceed 100°C.
- Dynamic performances (di/dt and response time) are best with a single bar completely filling the primary hole.
- In order to achieve the best magnetic coupling, the primary windings have to be wound over the top edge of the device.