

Current Transducer LA 200-P

For the electronic measurement of currents: DC, AC, pulsed..., with galvanic isolation between the primary circuit (high power) and the secondary circuit (electronic circuit).

$I_{PN} = 200 \text{ A}$



16044

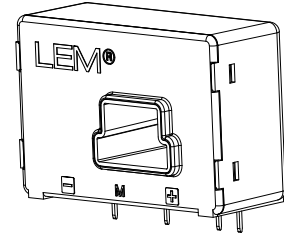

Electrical data

I_{PN}	Primary nominal current rms	200	A					
I_{PM}	Primary current, measuring range	0 .. ± 300	A					
R_M	Measuring resistance @	$T_A = 70^\circ\text{C}$		$T_A = 85^\circ\text{C}$				
		$R_{M \min}$	$R_{M \max}$	$R_{M \min}$	$R_{M \max}$			
		with ± 12 V	@ ± 200 A _{max}	0	30	0	26	Ω
			@ ± 250 A _{max}	0	8	0	4	Ω
	with ± 15 V	@ ± 200 A _{max}	0	60	0	56	Ω	
		@ ± 300 A _{max}	0	12	0	8	Ω	
I_{SN}	Secondary nominal current rms	100	mA					
K_N	Conversion ratio	1 : 2000						
V_C	Supply voltage (± 5 %)	± 12 .. 15	V					
I_C	Current consumption	16 (@ ± 15 V) + I_S	mA					

Accuracy - Dynamic performance data

X	Accuracy @ I_{PN} , $T_A = 25^\circ\text{C}$	@ ± 15 V (± 5 %)	± 0.40	%	
		@ ± 12 .. 15 V (± 5 %)	± 0.65	%	
ϵ_L	Linearity error		< 0.15	%	
I_O	Offset current @ $I_p = 0$, $T_A = 25^\circ\text{C}$	Typ		± 0.20	mA
		Max		± 0.25	mA
I_{OM}	Magnetic offset current ¹⁾ @ $I_p = 0$ and specified R_M , after an overload of 3 x I_{PN}			± 0.10 ± 0.25	mA
I_{OT}	Temperature variation of I_O	0°C .. + 70°C	± 0.10	± 0.25	mA
		- 40°C .. + 85°C	± 0.15	± 0.55	mA
t_{ra}	Reaction time to 10 % of I_{PN} step		< 500	ns	
t_r	Response time ^{2) 3)} to 90 % of I_{PN} step		< 1	µs	
di/dt	di/dt accurately followed ³⁾		> 200	A/µs	
BW	Frequency bandwidth (- 1 dB)		DC .. 100	kHz	

General data

T_A	Ambient operating temperature	- 40 .. + 85	°C	
T_S	Ambient storage temperature	- 40 .. + 90	°C	
R_S	Secondary coil resistance @	$T_A = 70^\circ\text{C}$	76	Ω
		$T_A = 85^\circ\text{C}$	80	Ω
m	Mass	40	g	
	Standards	EN 50178: 1997		

Notes: ¹⁾ The result of the coercive field of the magnetic circuit

²⁾ With a di/dt of 100 A/µs

³⁾ The primary conductor is best filling the through-hole and/or the return of the primary conductor is above the top of the transducer.

Features

- Closed loop (compensated) current transducer using the Hall effect
- Printed circuit board mounting
- Isolated plastic case recognized according to UL 94-V0.

Advantages

- Excellent accuracy
- Very good linearity
- Low temperature drift
- Optimized response time
- Wide frequency bandwidth
- No insertion losses
- High immunity to external interference
- Current overload capability.

Applications

- AC variable speed drives and servo motor drives
- Static converters for DC motor drives
- Battery supplied applications
- Uninterruptible Power Supplies (UPS)
- Switched Mode Power Supplies (SMPS)
- Power supplies for welding applications.

Application domain

- Industrial.

Current Transducer LA 200-P

Isolation characteristics

V_d	Rms voltage for AC isolation test, 50 Hz, 1 min	3	kV
\hat{V}_w	Impulse withstand voltage 1.2/50 μ s	7	kV
V_e	Partial discharge extinction voltage rms @ 10 pc	> 1.8	kV
		Min	
dCp	Creepage distance	6.7	mm
dCI	Clearance distance	6.7	mm
CTI	Comparative Tracking Index (group IIIa)	175	

Applications examples

According to EN 50178 and IEC 61010-1 standards and following conditions:

- Over voltage category OV 3
- Pollution degree PD2
- Non-uniform field

	EN 50178	IEC 61010-1
dCp, dCI, \hat{V}_w	Rated isolation voltage	Nominal voltage
Single isolation	600 V	600 V
Reinforced isolation	300 V	300 V

Safety



This transducer must be used in electric/electronic equipment with respect to applicable standards and safety requirements in accordance with the manufacturer's operating instructions.



Caution, risk of electrical shock

When operating the transducer, certain parts of the module can carry hazardous voltage (eg. primary busbar, power supply).

Ignoring this warning can lead to injury and/or cause serious damage.

This transducer is a build-in device, whose conducting parts must be inaccessible after installation.

A protective housing or additional shield could be used.

Main supply must be able to be disconnected.

Dimensions LA 200-P (in mm. 1 mm = 0.0394 inch)

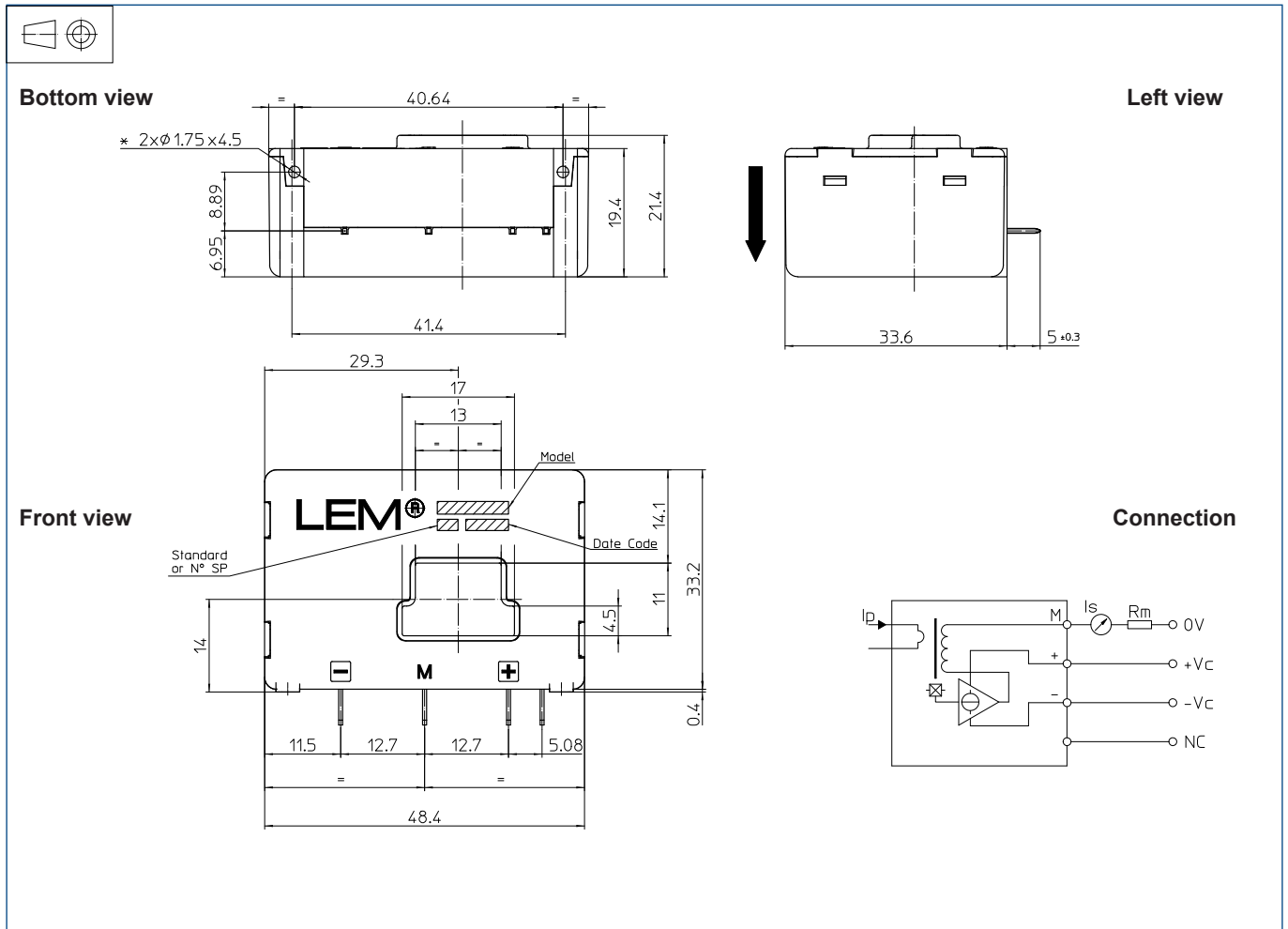

Mechanical characteristics

- General tolerance ± 0.2 mm
- Primary through-hole 17 x 11 mm
- Fastening & connection of secondary 4 pins
0.63 x 0.56 mm
- Recommended PCB hole 0.9 mm
- Supplementary fastening 2 holes \varnothing 1.75 mm
- Recommended PCB hole 2.4 mm
- Recommended screws PT KA 22 x 6.

Remarks

- I_s is positive when I_p flows in the direction of the arrow.
- Temperature of the primary conductor should not exceed 90°C.
- Dynamic performances (di/dt and response time) are best with a primary bar in low position in the through-hole.
- In order to achieve the best magnetic coupling, the primary windings have to be wound over the top edge of the device.
- This is a standard model. For different versions (supply voltages, turns ratios, unidirectional measurements...), please contact us.