

FEATURES/BENEFITS

- Latest generation MOSFET technology
- Ultra low on-state resistance
- Innovative isolated driver ensures fast power transistor turn on and off and thus low power transient
- Ultra low output leakage current
- Low control current consumption
- Triggered control input to avoid linear control risks
- Low conducted and radiated disturbances



Part Number	Description
S20DC30	30A, 200 Vdc Solid-State Relay

Part Number Explanation

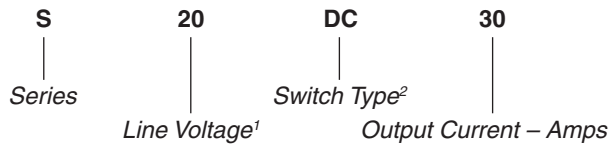

NOTES

- 1) Line Voltage (peak): 20 = 200 Vdc
- 2) Switch Type: DC = DC

ELECTRICAL SPECIFICATIONS

(+25°C ambient temperature unless otherwise specified)

INPUT (CONTROL) SPECIFICATIONS

	Min	Max	Units
Control Range	4.5	32	Vdc
Input Current Range	25	42	mAdc
Typical Turn-On Voltage	4.3		Vdc
Must Turn-Off Voltage	1		Vdc
Reverse Voltage		32	Vdc
Reverse Leakage Current		100	µA

CONTROL CHARACTERISTIC

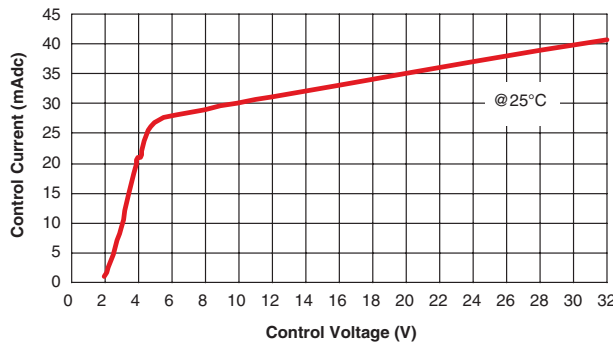
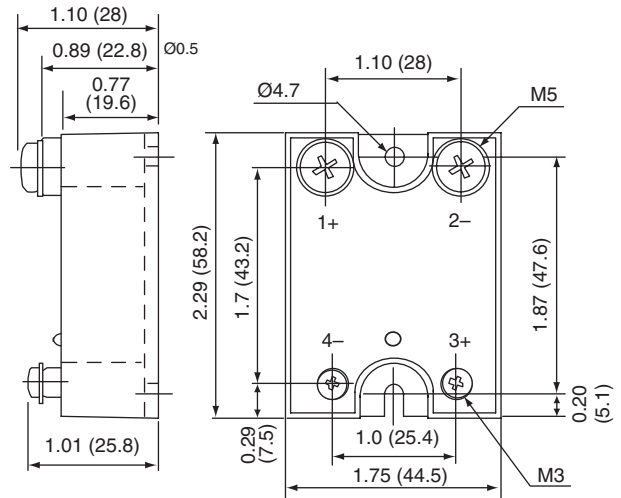

Figure 2

MECHANICAL SPECIFICATION



Tolerances: Ø0.3
Dimensions in inches (mm)
Weight: 3.52 oz. (100g)

Figure 1

BLOCK DIAGRAM

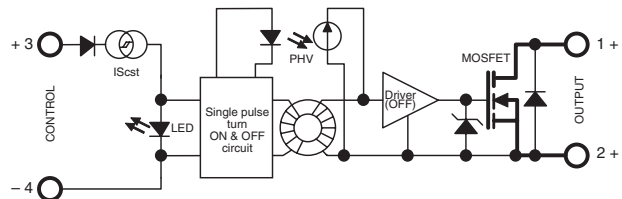

Figure 3

ELECTRICAL SPECIFICATIONS

(+25°C ambient temperature unless otherwise specified)

OUTPUT (LOAD) SPECIFICATIONS

	Min	Max	Units
Operating Range	0	130	Vdc
Peak Voltage		200	Vpeak
Reverse Voltage (Internal Diode)	1.5		V
Maximum Repetitive Avalanche Current	30		A
Maximum Single Pulse Avalanche Energy		315	mJ
Maximum Repetitive Pulse Avalanche Energy		20	mJ
Maximum Nominal Currents (Resistive)	30		A
Non-Repetitive Peak Overload Current	120		A
Leakage Current		100	µA _{dc}
On-State Resistance		164	mΩ
Output Capacitance (Typical)	3.0		nF
Junction-Case Thermal Resistance	0.75		°C/W
Built-In Heat Sink Thermal Resistance (Vertically Mounted)	8		°C/W
Heat Sink Thermal Time Constant	10		min
Control Inputs/Power Outputs			
Insulation Voltage	4		kV
Turn-On Time		10	µs
Turn-On Delay		600	µs
Turn-Off Time		10	µs
Turn-Off Delay		100	µs
On-Off Frequency		700	Hz

TIME DIAGRAMS

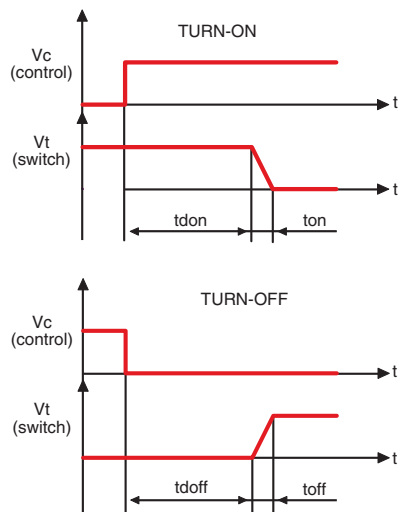

Figure 6

HIGH SIDE WIRING DIAGRAM
(Load Connected to “-”)

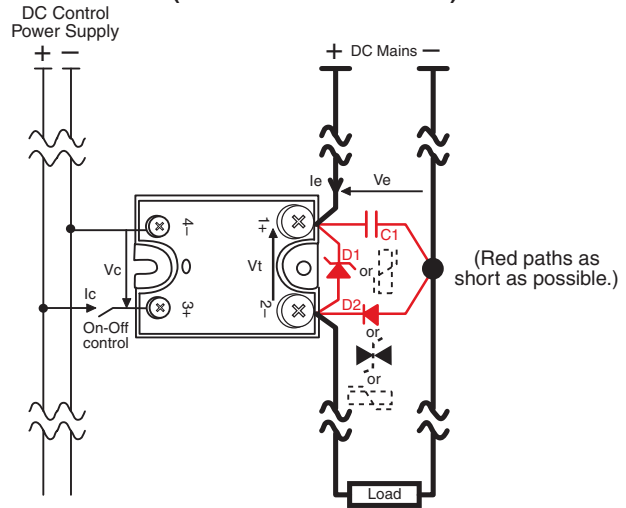

Figure 4

LOW SIDE WIRING DIAGRAM
(Load Connected to “+”)

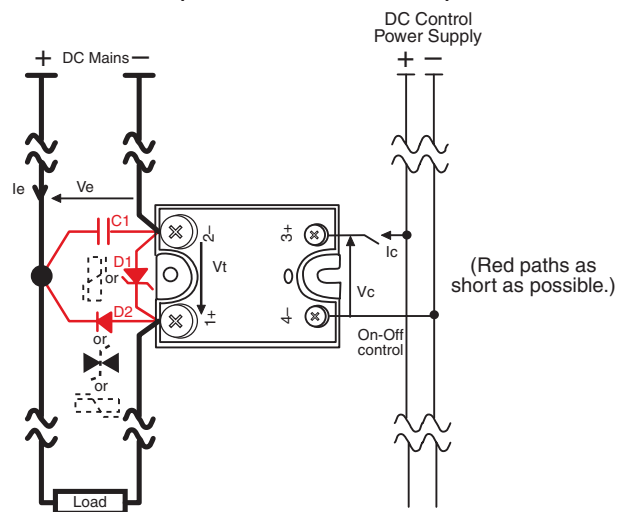

Figure 5

ON RESISTANCE VS. TEMPERATURE

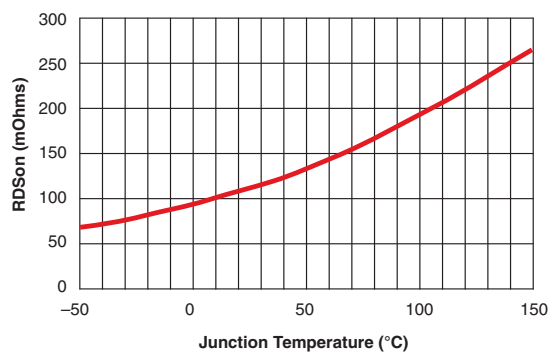

Figure 7

