

IS61WV51216EDALL IS61/64WV51216EDBLL



512K x 16 HIGH-SPEED ASYNCHRONOUS CMOS STATIC RAM WITH ECC

FEBRUARY 2013

FEATURES

- High-speed access times: 8, 10, 20 ns
- High-performance, low-power CMOS process
- Multiple center power and ground pins for greater noise immunity
- Easy memory expansion with \overline{CE} and \overline{OE} options
- \overline{CE} power-down
- Fully static operation: no clock or refresh required
- TTL compatible inputs and outputs
- Single Power Supply
 - $V_{DD} = 1.65V$ to $2.2V$ (IS61WV51216EDALL)
 - $V_{DD} = 2.4V$ to $3.6V$ (IS61/64WV51216EDBLL)
- Packages available:
 - 48-ball miniBGA (6mm x 8mm)
 - 44-pin TSOP (Type II)
- Industrial and Automotive Temperature Support
- Lead-free available
- Data control for upper and lower bytes

DESCRIPTION

The *ISSI* IS61WV51216EDALL and IS61/64WV51216EDBLL are high-speed, 8M-bit static RAMs organized as 512K words by 16 bits. It is fabricated using *ISSI*'s high-performance CMOS technology. This highly reliable process coupled with innovative circuit design techniques, yields high-performance and low power consumption devices.

When \overline{CE} is HIGH (deselected), the device assumes a standby mode at which the power dissipation can be reduced down with CMOS input levels.

Easy memory expansion is provided by using Chip Enable and Output Enable inputs, \overline{CE} and \overline{OE} . The active LOW Write Enable (\overline{WE}) controls both writing and reading of the memory. A data byte allows Upper Byte (\overline{UB}) and Lower Byte (\overline{LB}) access.

The device is packaged in the JEDEC standard 44-pin TSOP Type II and 48-pin Mini BGA (6mm x 8mm).

FUNCTIONAL BLOCK DIAGRAM

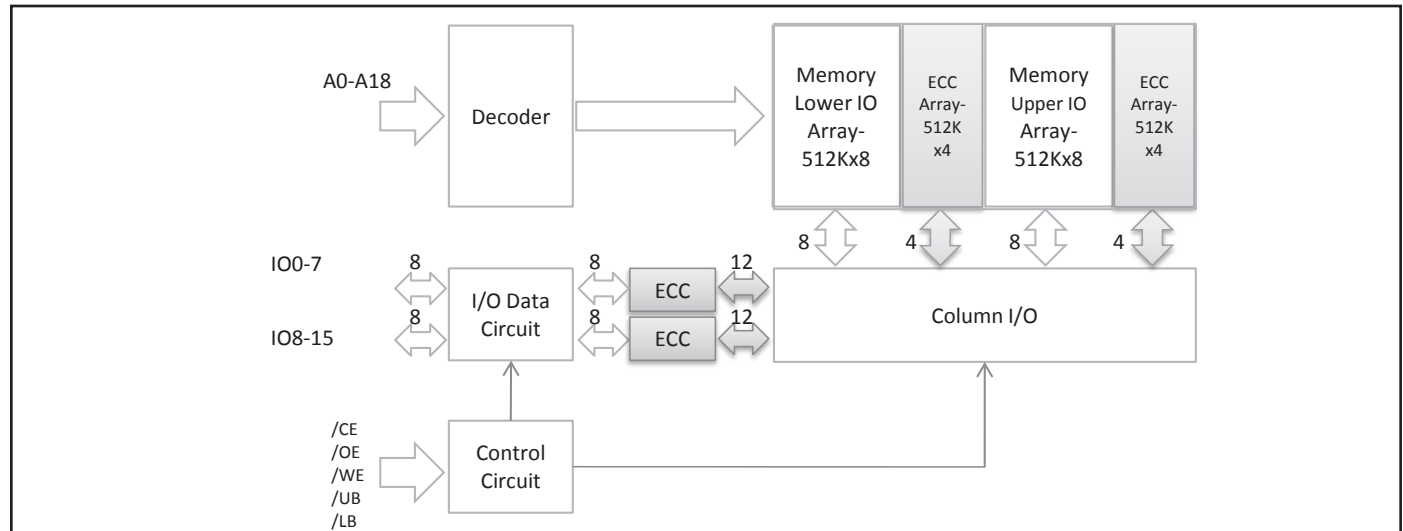

Copyright © 2013 Integrated Silicon Solution, Inc. All rights reserved. ISSI reserves the right to make changes to this specification and its products at any time without notice. ISSI assumes no liability arising out of the application or use of any information, products or services described herein. Customers are advised to obtain the latest version of this device specification before relying on any published information and before placing orders for products.

Integrated Silicon Solution, Inc. does not recommend the use of any of its products in life support applications where the failure or malfunction of the product can reasonably be expected to cause failure of the life support system or to significantly affect its safety or effectiveness. Products are not authorized for use in such applications unless Integrated Silicon Solution, Inc. receives written assurance to its satisfaction, that:

- a.) the risk of injury or damage has been minimized;
- b.) the user assume all such risks; and
- c.) potential liability of Integrated Silicon Solution, Inc is adequately protected under the circumstances

48-pin mini BGA (6mm x 8mm)

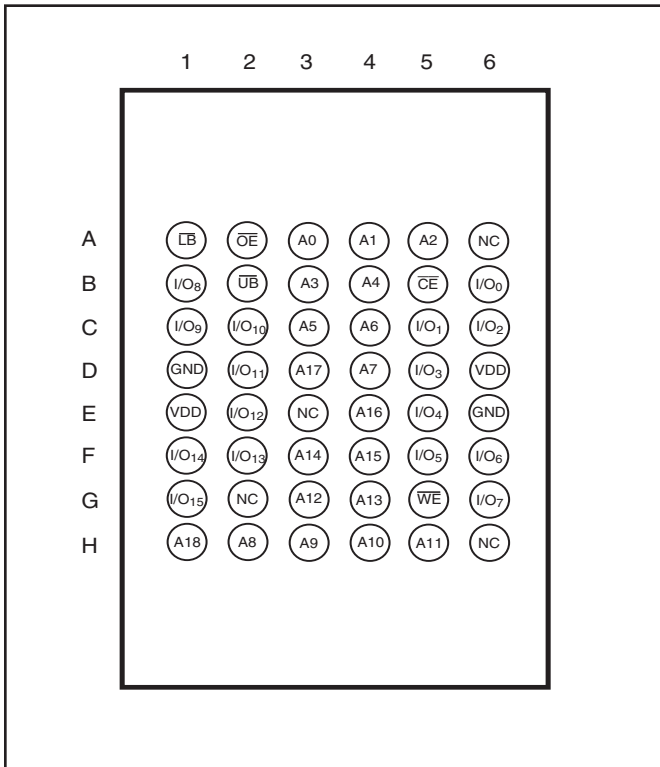

PIN DESCRIPTIONS

A0-A18	Address Inputs
I/O0-I/O15	Data Inputs/Outputs
\overline{CE}	Chip Enable Input
\overline{OE}	Output Enable Input
\overline{WE}	Write Enable Input
\overline{LB}	Lower-byte Control (I/O0-I/O7)
\overline{UB}	Upper-byte Control (I/O8-I/O15)
NC	No Connection
V _{DD}	Power
GND	Ground

PIN CONFIGURATIONS

44-Pin TSOP (Type II)

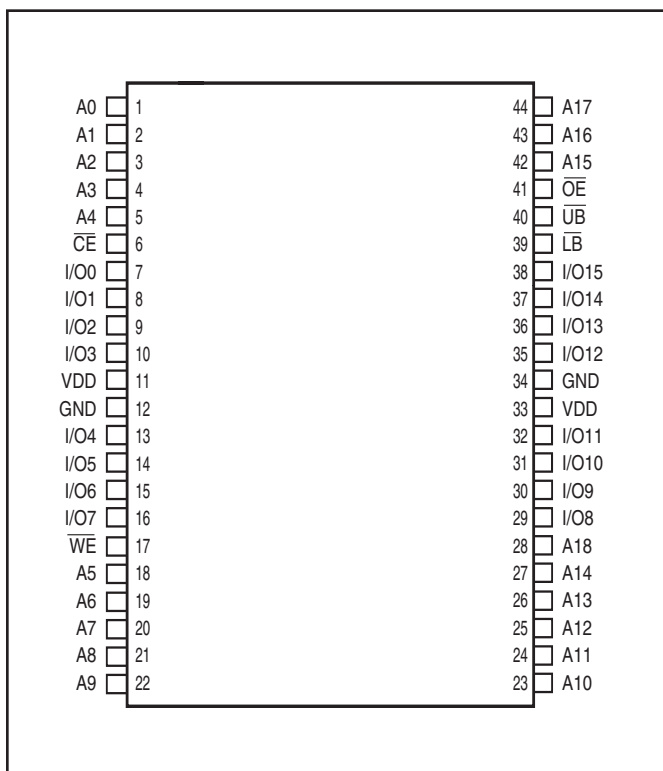

PIN DESCRIPTIONS

A0-A18	Address Inputs
I/O0-I/O15	Data Inputs/Outputs
\overline{CE}	Chip Enable Input
\overline{OE}	Output Enable Input
\overline{WE}	Write Enable Input
\overline{LB}	Lower-byte Control (I/O0-I/O7)
\overline{UB}	Upper-byte Control (I/O8-I/O15)
NC	No Connection
V _{DD}	Power
GND	Ground

TRUTH TABLE

Mode	\overline{WE}	\overline{CE}	\overline{OE}	\overline{LB}	\overline{UB}	I/O PIN		V _{DD} Current
						I/O0-I/O7	I/O8-I/O15	
Not Selected	X	H	X	X	X	High-Z	High-Z	I _{SB1} , I _{SB2}
Output Disabled	H	L	H	X	X	High-Z	High-Z	I _{CC}
	X	L	X	H	H	High-Z	High-Z	
Read	H	L	L	L	H	D _{OUT}	High-Z	I _{CC}
	H	L	L	H	L	High-Z	D _{OUT}	
	H	L	L	L	L	D _{OUT}	D _{OUT}	
Write	L	L	X	L	H	D _{IN}	High-Z	I _{CC}
	L	L	X	H	L	High-Z	D _{IN}	
	L	L	X	L	L	D _{IN}	D _{IN}	

ABSOLUTE MAXIMUM RATINGS⁽¹⁾

Symbol	Parameter	Value	Unit
V _{TERM}	Terminal Voltage with Respect to GND	-0.5 to V _{DD} + 0.5	V
V _{DD}	V _{DD} Relates to GND	-0.3 to 4.0	V
T _{STG}	Storage Temperature	-65 to +150	°C
P _T	Power Dissipation	1.0	W

Notes:

1. Stress greater than those listed under ABSOLUTE MAXIMUM RATINGS may cause permanent damage to the device. This is a stress rating only and functional operation of the device at these or any other conditions above those indicated in the operational sections of this specification is not implied. Exposure to absolute maximum rating conditions for extended periods may affect reliability.

CAPACITANCE^(1,2)

Symbol	Parameter	Conditions	Max.	Unit
C _{IN}	Input Capacitance	V _{IN} = 0V	6	pF
C _{I/O}	Input/Output Capacitance	V _{OUT} = 0V	8	pF

Notes:

1. Tested initially and after any design or process changes that may affect these parameters.
2. Test conditions: T_A = 25°C, f = 1 MHz, V_{DD} = 3.3V.

OPERATING RANGE (V_{DD})

Range	Ambient Temperature	IS61WV51216EDALL V _{DD} (20ns)	IS61WV51216EDBLL V _{DD} (8, 10ns)	IS64WV51216EDBLL V _{DD} (10ns)
Industrial	-40°C to +85°C	1.65V-2.2V	2.4V-3.6V	—
Automotive (A1)	-40°C to +85°C	—	—	2.4V-3.6V
Automotive (A3)	-40°C to +125°C	—	—	2.4V-3.6V

ERROR DETECTION AND ERROR CORRECTION

- Independent ECC for each byte
- Detect and correct one bit error per byte
- Better reliability than parity code schemes which can only detect an error but not correct an error
- Backward Compatible: Drop in replacement to current in industry standard devices (without ECC)

DC ELECTRICAL CHARACTERISTICS (Over Operating Range)

V_{DD} = 2.4V-3.6V

Symbol	Parameter	Test Conditions	Min.	Max.	Unit
V _{OH}	Output HIGH Voltage	V _{DD} = Min., I _{OH} = -1.0 mA	1.8	—	V
V _{OL}	Output LOW Voltage	V _{DD} = Min., I _{OL} = 1.0 mA	—	0.4	V
V _{IH}	Input HIGH Voltage		2.0	V _{DD} + 0.3	V
V _{IL}	Input LOW Voltage ⁽¹⁾		-0.3	0.8	V
I _{LI}	Input Leakage	GND ≤ V _{IN} ≤ V _{DD}	-1	1	μA
I _{LO}	Output Leakage	GND ≤ V _{OUT} ≤ V _{DD} , Outputs Disabled	-1	1	μA

Note:

- V_{IL} (min.) = -0.3V DC; V_{IL} (min.) = -2.0V AC (pulse width < 2 ns). Not 100% tested.
V_{IH} (max.) = V_{DD} + 0.3V DC; V_{IH} (max.) = V_{DD} + 2.0V AC (pulse width < 2 ns). Not 100% tested.

DC ELECTRICAL CHARACTERISTICS (Over Operating Range)

V_{DD} = 1.65V-2.2V

Symbol	Parameter	Test Conditions	Min.	Max.	Unit
V _{OH}	Output HIGH Voltage	I _{OH} = -0.1 mA	1.4	—	V
V _{OL}	Output LOW Voltage	I _{OL} = 0.1 mA	—	0.2	V
V _{IH}	Input HIGH Voltage		1.4	V _{DD} + 0.2	V
V _{IL}	Input LOW Voltage		-0.2	0.4	V
I _{LI}	Input Leakage	GND ≤ V _{IN} ≤ V _{DD}	-1	1	μA
I _{LO}	Output Leakage	GND ≤ V _{OUT} ≤ V _{DD} , Outputs Disabled	-1	1	μA

Notes:

- V_{IL} (min.) = -0.3V DC; V_{IL} (min.) = -1.0V AC (pulse width < 2 ns). Not 100% tested.
V_{IH} (max.) = V_{DD} + 0.3V DC; V_{IH} (max.) = V_{DD} + 1.0V AC (pulse width < 2 ns). Not 100% tested.

AC TEST CONDITIONS

Parameter	Unit (2.4V-3.6V)	Unit (3.3V ± 5%)	Unit (1.65V-2.2V)
Input Pulse Level	0.4V to V _{DD} - 0.3V	0.4V to V _{DD} - 0.3V	0.4V to V _{DD} - 0.3V
Input Rise and Fall Times	1V/ ns	1V/ ns	1V/ ns
Input and Output Timing and Reference Level (V _{Ref})	V _{DD} / 2	$\frac{V_{DD}}{2} + 0.05$	0.9V
Output Load	See Figures 1 and 2	See Figures 1 and 2	See Figures 1 and 2
R1 (Ω)	1909	317	13500
R2 (Ω)	1105	351	10800
V _{TM} (V)	3.0V	3.3V	1.8V

AC TEST LOADS

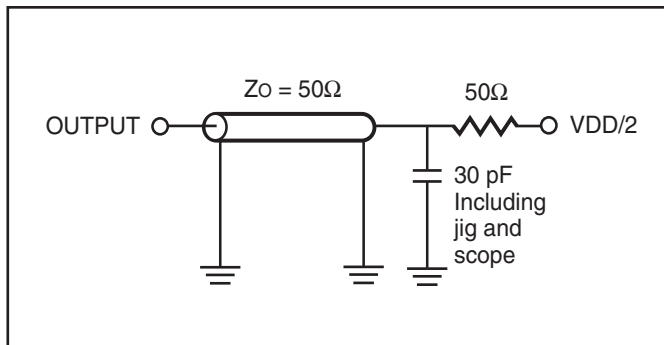

Figure 1.

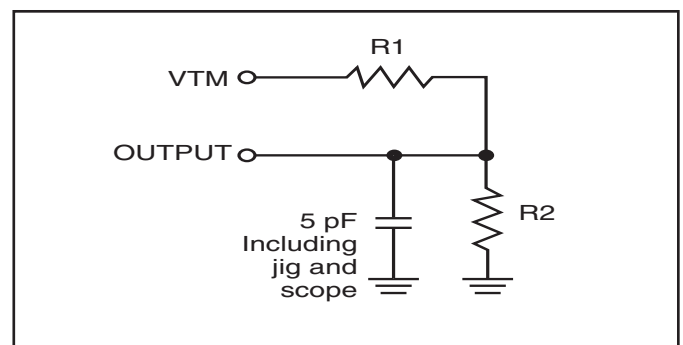

Figure 2.

POWER SUPPLY CHARACTERISTICS⁽¹⁾ (Over Operating Range)

Symbol	Parameter	Test Conditions		-8		-10		-20		Unit
				Min.	Max.	Min.	Max.	Min.	Max.	
I _{CC}	V _{DD} Dynamic Operating Supply Current	V _{DD} = Max., I _{OUT} = 0 mA, f = f _{MAX}	Com.	—	45	—	40	—	30	mA
			Ind.	—	55	—	50	—	40	
			Auto. typ. ⁽²⁾	—	—	—	65	—	55	
				15						
I _{CC1}	Operating Supply Current	V _{DD} = Max., I _{OUT} = 0 mA, f = 0	Com.	—	20	—	20	—	20	mA
			Ind.	—	25	—	25	—	25	
			Auto.	—	—	—	50	—	50	
I _{SB1}	TTL Standby Current (TTL Inputs)	V _{DD} = Max., V _{IN} = V _{IH} or V _{IL} $\overline{CE} \geq V_{IH}$, f = 0	Com.	—	20	—	20	—	20	mA
			Ind.	—	25	—	25	—	25	
			Auto.	—	—	—	45	—	45	
I _{SB2}	CMOS Standby Current (CMOS Inputs)	V _{DD} = Max., $\overline{CE} \geq V_{DD} - 0.2V$, V _{IN} ≥ V _{DD} - 0.2V, or V _{IN} ≤ 0.2V, f = 0	Com.	—	10	—	10	—	10	mA
			Ind.	—	15	—	15	—	15	
			Auto. typ. ⁽²⁾	—	—	—	35	—	35	
				2						

Note:

- At f = f_{MAX}, address and data inputs are cycling at the maximum frequency, f = 0 means no input lines change.
- Typical values are measured at V_{DD} = 3.0V, T_A = 25°C and not 100% tested.

READ CYCLE SWITCHING CHARACTERISTICS⁽¹⁾ (Over Operating Range)

Symbol	Parameter	-8		-10		Unit
		Min.	Max.	Min.	Max.	
t _{RC}	Read Cycle Time	8	—	10	—	ns
t _{AA}	Address Access Time	—	8	—	10	ns
t _{OHA}	Output Hold Time	2.5	—	2.5	—	ns
t _{ACE}	\overline{CE} Access Time	—	8	—	10	ns
t _{DOE}	\overline{OE} Access Time	—	5.5	—	6.5	ns
t _{HZOE⁽²⁾}	\overline{OE} to High-Z Output	—	3	—	4	ns
t _{LZOE⁽²⁾}	\overline{OE} to Low-Z Output	0	—	0	—	ns
t _{HZCE⁽²⁾}	\overline{CE} to High-Z Output	0	3	0	4	ns
t _{LZCE⁽²⁾}	\overline{CE} to Low-Z Output	3	—	3	—	ns
t _{BA}	\overline{LB} , \overline{UB} Access Time	—	5.5	—	6.5	ns
t _{HZB⁽²⁾}	\overline{LB} , \overline{UB} to High-Z Output	0	3	0	3	ns
t _{LZB⁽²⁾}	\overline{LB} , \overline{UB} to Low-Z Output	0	—	0	—	ns
t _{PU}	Power Up Time	0	—	0	—	ns
t _{PD}	Power Down Time	—	8	—	10	ns

Notes:

1. Test conditions and output loading conditions are specified in the AC Test Conditions and AC Test Loads (Figure 1).
2. Tested with the load in Figure 2. Transition is measured ± 500 mV from steady-state voltage.

READ CYCLE SWITCHING CHARACTERISTICS⁽¹⁾ (Over Operating Range)

Symbol	Parameter	-20 ns		Unit
		Min.	Max.	
t _{RC}	Read Cycle Time	20	—	ns
t _{AA}	Address Access Time	—	20	ns
t _{OHA}	Output Hold Time	2.5	—	ns
t _{ACE}	\overline{CE} Access Time	—	20	ns
t _{DOE}	\overline{OE} Access Time	—	8	ns
t _{HZOE⁽²⁾}	\overline{OE} to High-Z Output	0	8	ns
t _{LZOE⁽²⁾}	\overline{OE} to Low-Z Output	0	—	ns
t _{HZCE⁽²⁾}	\overline{CE} to High-Z Output	0	8	ns
t _{LZCE⁽²⁾}	\overline{CE} to Low-Z Output	3	—	ns
t _{BA}	\overline{LB} , \overline{UB} Access Time	—	8	ns
t _{HZB}	\overline{LB} , \overline{UB} to High-Z Output	0	8	ns
t _{LZB}	\overline{LB} , \overline{UB} to Low-Z Output	0	—	ns

Notes:

1. Test conditions and output loading conditions are specified in the AC Test Conditions and AC Test Loads (Figure 1).
2. Tested with the load in Figure 1b. Transition is measured ± 500 mV from steady-state voltage. Not 100% tested.
3. Not 100% tested.

AC WAVEFORMS

READ CYCLE NO. 1^(1,2) (Address Controlled) ($\overline{CE} = \overline{OE} = V_{IL}$)

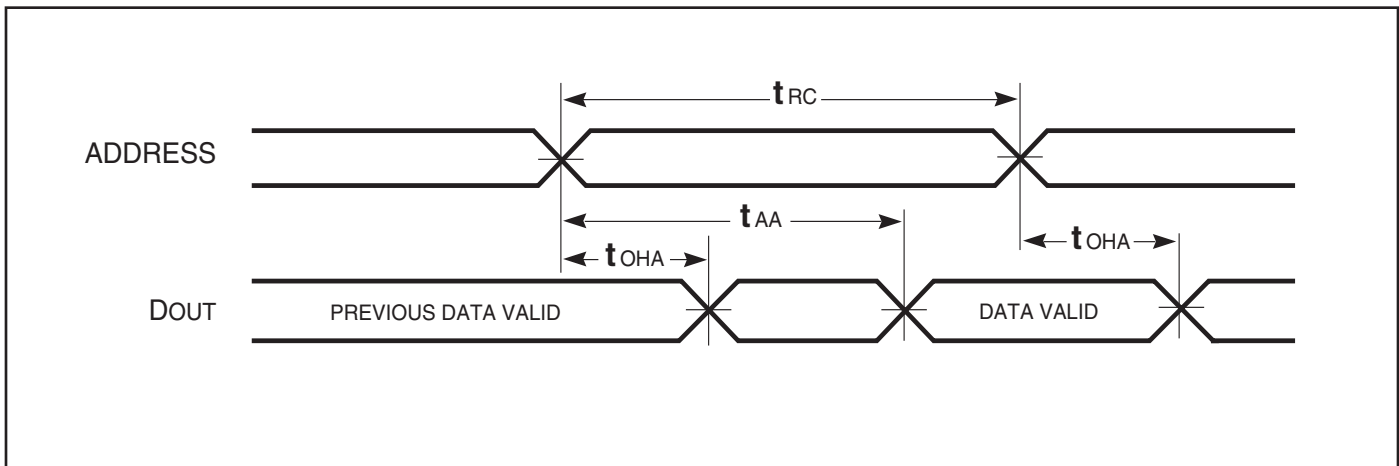

READ CYCLE NO. 2^(1,3) (\overline{CE} and \overline{OE} Controlled)

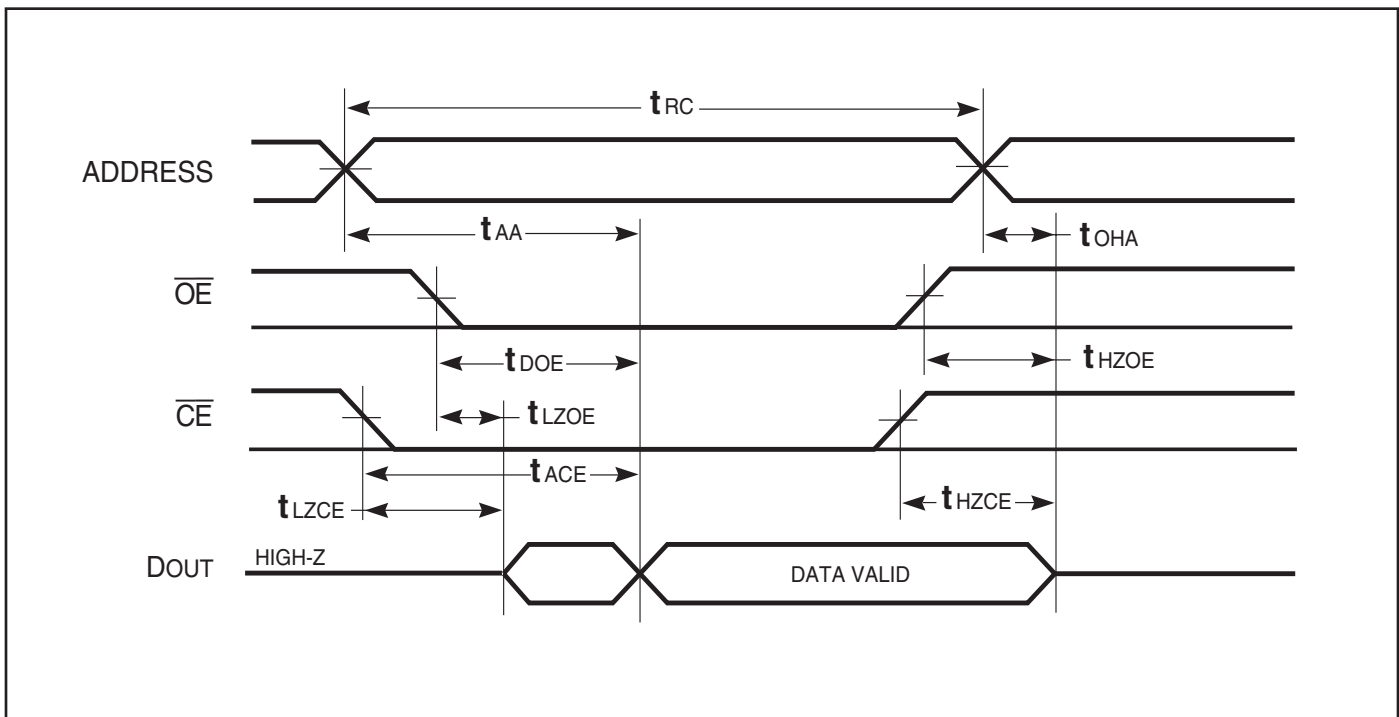

Notes:

1. \overline{WE} is HIGH for a Read Cycle.
2. The device is continuously selected. \overline{OE} , $\overline{CE} = V_{IL}$.
3. Address is valid prior to or coincident with \overline{CE} LOW transitions.

WRITE CYCLE SWITCHING CHARACTERISTICS^(1,3) (Over Operating Range)

Symbol	Parameter	-8		-10		Unit
		Min.	Max.	Min.	Max.	
t _{WC}	Write Cycle Time	8	—	10	—	ns
t _{SCE}	\overline{CE} to Write End	6.5	—	8	—	ns
t _{AW}	Address Setup Time to Write End	6.5	—	8	—	ns
t _{HA}	Address Hold from Write End	0	—	0	—	ns
t _{SA}	Address Setup Time	0	—	0	—	ns
t _{PWB}	\overline{LB} , \overline{UB} Valid to End of Write	6.5	—	8	—	ns
t _{PWE1}	\overline{WE} Pulse Width	6.5	—	8	—	ns
t _{PWE2}	\overline{WE} Pulse Width ($\overline{OE} = \text{LOW}$)	8.0	—	10	—	ns
t _{SD}	Data Setup to Write End	5	—	6	—	ns
t _{HD}	Data Hold from Write End	0	—	0	—	ns
t _{HZWE⁽²⁾}	\overline{WE} LOW to High-Z Output	—	3.5	—	5	ns
t _{LZWE⁽²⁾}	\overline{WE} HIGH to Low-Z Output	2	—	2	—	ns

Notes:

1. Test conditions and output loading conditions are specified in the AC Test Conditions and AC Test Loads (Figure 1).
2. Tested with the load in Figure 2. Transition is measured ± 500 mV from steady-state voltage. Not 100% tested.
3. The internal write time is defined by the overlap of \overline{CE} LOW and \overline{UB} or \overline{LB} , and \overline{WE} LOW. All signals must be in valid states to initiate a Write, but any one can go inactive to terminate the Write. The Data Input Setup and Hold timing are referenced to the rising or falling edge of the signal that terminates the write. Shaded area product in development

WRITE CYCLE SWITCHING CHARACTERISTICS^(1,2) (Over Operating Range)

Symbol	Parameter	-20 ns		Unit
		Min.	Max.	
t _{WC}	Write Cycle Time	20	—	ns
t _{SCE}	\overline{CE} to Write End	12	—	ns
t _{AW}	Address Setup Time to Write End	12	—	ns
t _{HA}	Address Hold from Write End	0	—	ns
t _{SA}	Address Setup Time	0	—	ns
t _{PWB}	\overline{LB} , \overline{UB} Valid to End of Write	12	—	ns
t _{PWE1}	\overline{WE} Pulse Width ($\overline{OE} = \text{HIGH}$)	12	—	ns
t _{PWE2}	\overline{WE} Pulse Width ($\overline{OE} = \text{LOW}$)	17	—	ns
t _{SD}	Data Setup to Write End	9	—	ns
t _{HD}	Data Hold from Write End	0	—	ns
t _{HZWE⁽²⁾}	\overline{WE} LOW to High-Z Output	—	9	ns
t _{LZWE⁽²⁾}	\overline{WE} HIGH to Low-Z Output	3	—	ns

Notes:

1. Test conditions and output loading conditions are specified in the AC Test Conditions and AC Test Loads (Figure 1).
2. Tested with the load in Figure 1b. Transition is measured ± 500 mV from steady-state voltage. Not 100% tested.
3. The internal write time is defined by the overlap of \overline{CE} LOW and \overline{UB} or \overline{LB} , and \overline{WE} LOW. All signals must be in valid states to initiate a Write, but any one can go inactive to terminate the Write. The Data Input Setup and Hold timing are referenced to the rising or falling edge of the signal that terminates the write.

AC WAVEFORMS

WRITE CYCLE NO. 1^(1,2) (\overline{CE} Controlled, \overline{OE} = HIGH or LOW)

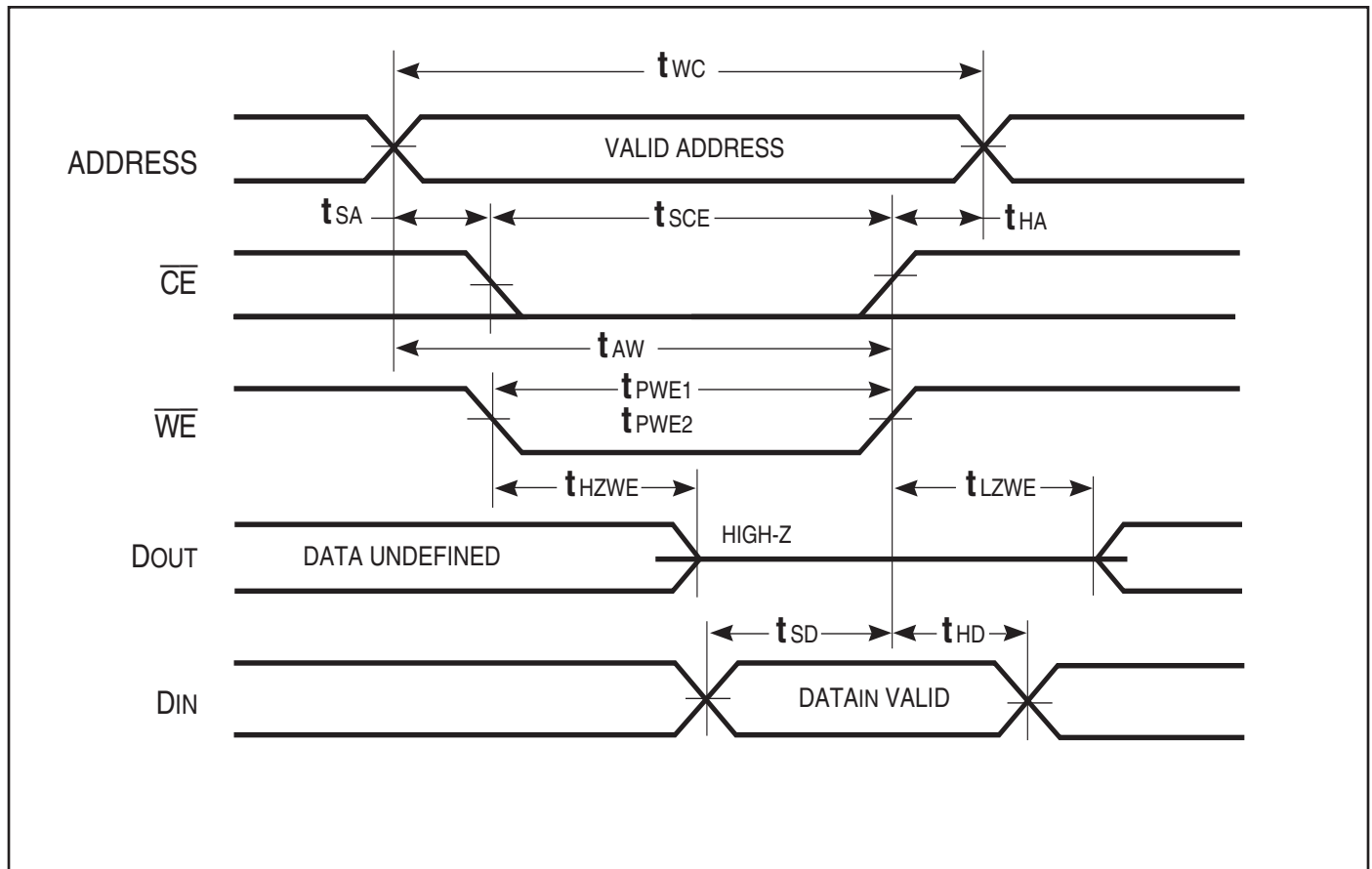

AC WAVEFORMS

WRITE CYCLE NO. 2 (\overline{WE} Controlled. \overline{OE} is HIGH During Write Cycle) ^(1,2)

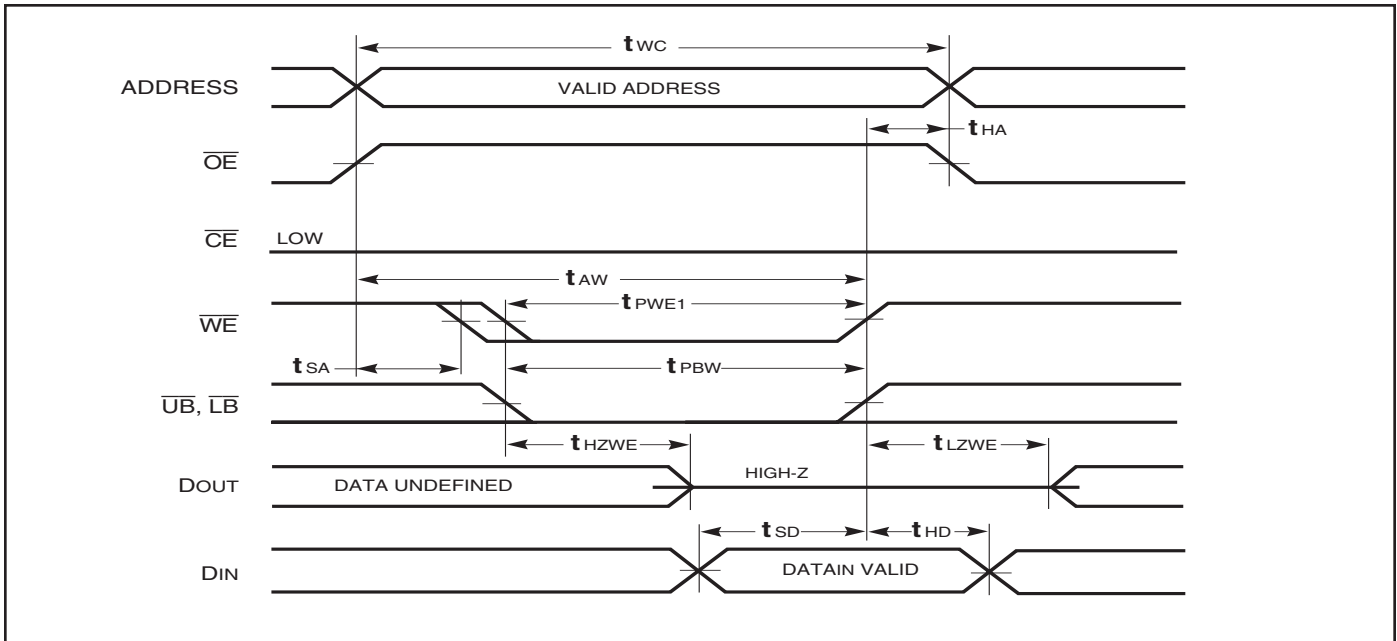

WRITE CYCLE NO. 3 (\overline{WE} Controlled. \overline{OE} is LOW During Write Cycle) ⁽¹⁾

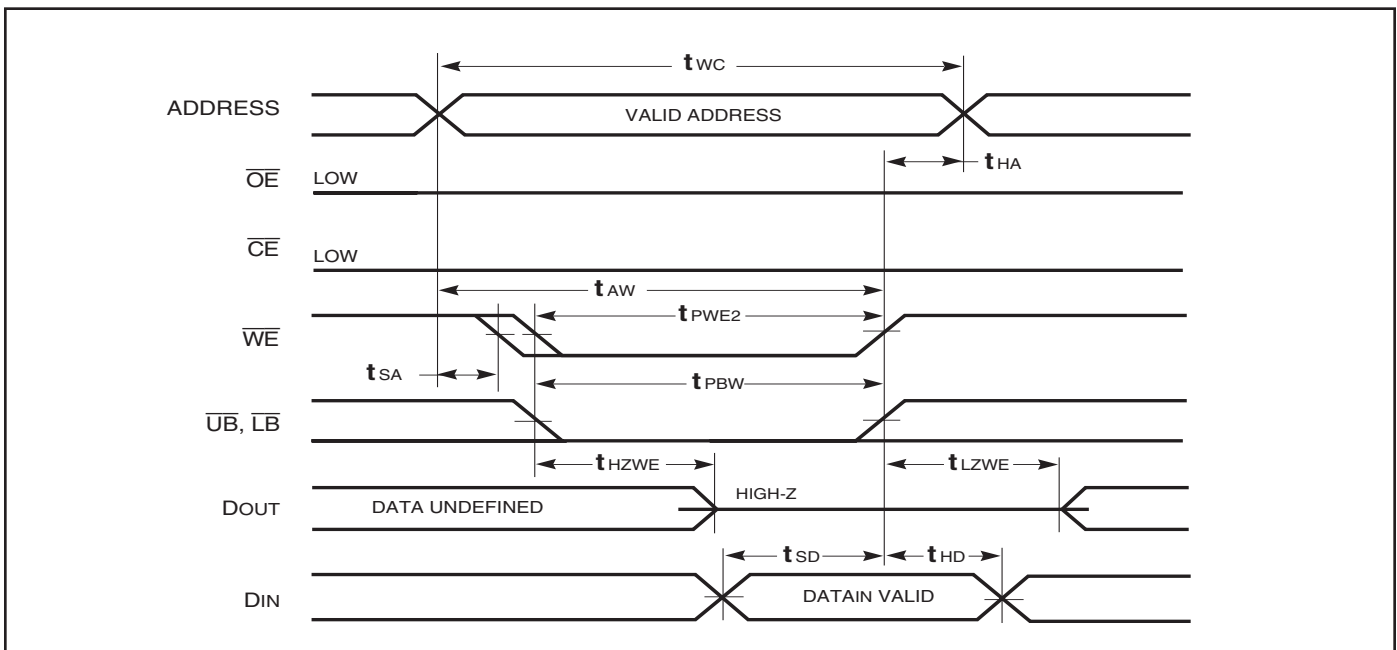

AC WAVEFORMS

WRITE CYCLE NO. 4 ($\overline{\text{LB}}$, $\overline{\text{UB}}$ Controlled, Back-to-Back Write) ^(1,3)

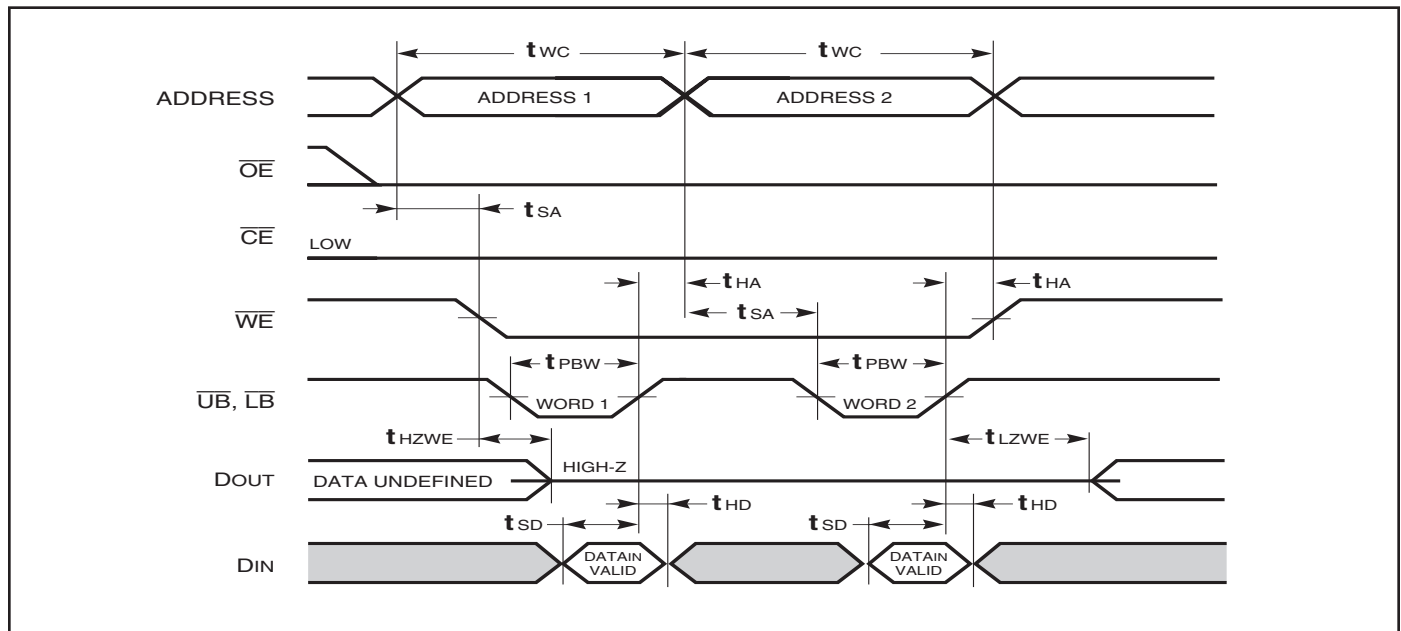

Notes:

1. The internal Write time is defined by the overlap of $\overline{\text{CE}} = \text{LOW}$, $\overline{\text{UB}}$ and/or $\overline{\text{LB}} = \text{LOW}$, and $\overline{\text{WE}} = \text{LOW}$. All signals must be in valid states to initiate a Write, but any can be deasserted to terminate the Write. The t_{SA} , t_{HA} , t_{SD} , and t_{HD} timing is referenced to the rising or falling edge of the signal that terminates the Write.
2. Tested with $\overline{\text{OE}}$ HIGH for a minimum of 4 ns before $\overline{\text{WE}} = \text{LOW}$ to place the I/O in a HIGH-Z state.
3. $\overline{\text{WE}}$ may be held LOW across many address cycles and the $\overline{\text{LB}}$, $\overline{\text{UB}}$ pins can be used to control the Write function.

DATA RETENTION SWITCHING CHARACTERISTICS (2.4V-3.6V)

Symbol	Parameter	Test Condition	Options	Min.	Typ. ⁽¹⁾	Max.	Unit
V _{DR}	V _{DD} for Data Retention	See Data Retention Waveform		2.0	—	3.6	V
I _{DR}	Data Retention Current	V _{DD} = V _{DR(MIN)} , $\overline{CE} \geq V_{DD} - 0.2V$	Com. Ind. Auto.	—	2	10 15 35	mA
t _{SDR}	Data Retention Setup Time	See Data Retention Waveform		0	—	—	ns
t _{RDR}	Recovery Time	See Data Retention Waveform		t _{RC}	—	—	ns

Note 1: Typical values are measured at V_{DD} = V_{DR(MIN)}, T_A = 25°C and not 100% tested.

DATA RETENTION SWITCHING CHARACTERISTICS (1.65V-2.2V)

Symbol	Parameter	Test Condition	Options	Min.	Typ. ⁽¹⁾	Max.	Unit
V _{DR}	V _{DD} for Data Retention	See Data Retention Waveform		1.2	—	3.6	V
I _{DR}	Data Retention Current	V _{DD} = V _{DR(MIN)} , $\overline{CE} \geq V_{DD} - 0.2V$	Com. Ind. Auto.	—	2	10 15 35	mA
t _{SDR}	Data Retention Setup Time	See Data Retention Waveform		0	—	—	ns
t _{RDR}	Recovery Time	See Data Retention Waveform		t _{RC}	—	—	ns

Note 1: Typical values are measured at V_{DD} = V_{DR(MIN)}, T_A = 25°C and not 100% tested.

DATA RETENTION WAVEFORM (\overline{CE} Controlled)

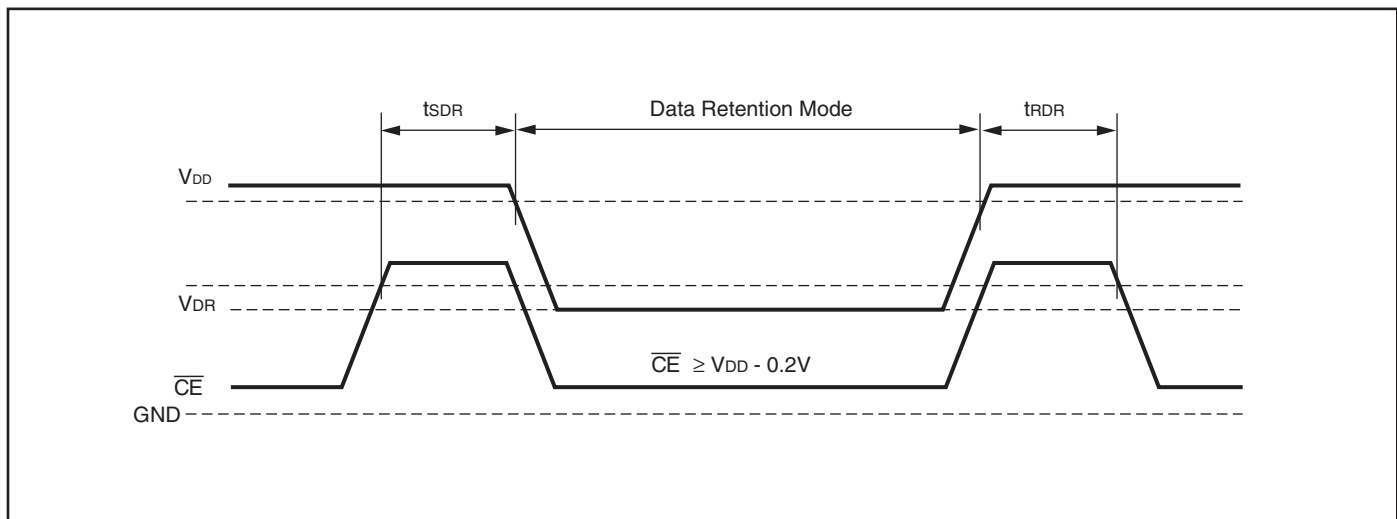

ORDERING INFORMATION

Industrial Range: -40°C to +85°C

Voltage Range: 2.4V to 3.6V

Speed (ns)	Order Part No.	Package
8	IS61WV51216EDBLL-8BLI	48 mini BGA (6mm x 8mm), Lead-free
	IS61WV51216EDBLL-8TLI	TSOP (Type II), Lead-free
10	IS61WV51216EDBLL-10BI	48 mini BGA (6mm x 8mm)
	IS61WV51216EDBLL-10BLI	48 mini BGA (6mm x 8mm), Lead-free
	IS61WV51216EDBLL-10TI	TSOP (Type II)
	IS61WV51216EDBLL-10TLI	TSOP (Type II), Lead-free

Industrial Range: -40°C to +85°C

Voltage Range: 1.65V to 2.2V

Speed (ns)	Order Part No.	Package
20	IS61WV51216EDALL-20BLI	48 mini BGA (6mm x 8mm), Lead-free
	IS61WV51216EDALL-20TLI	TSOP (Type II), Lead-free

Automotive Range: -40°C to +125°C

Voltage Range: 2.4V to 3.6V

Speed (ns)	Order Part No.	Package
10	IS64WV51216EDBLL-10BA3	48 mini BGA (6mm x 8mm)
	IS64WV51216EDBLL-10BLA3	48 mini BGA (6mm x 8mm), Lead-free
	IS64WV51216EDBLL-10CTA3	TSOP (Type II), Copper Leadframe
	IS64WV51216EDBLL-10CTLA3	TSOP (Type II), Lead-free, Copper Leadframe

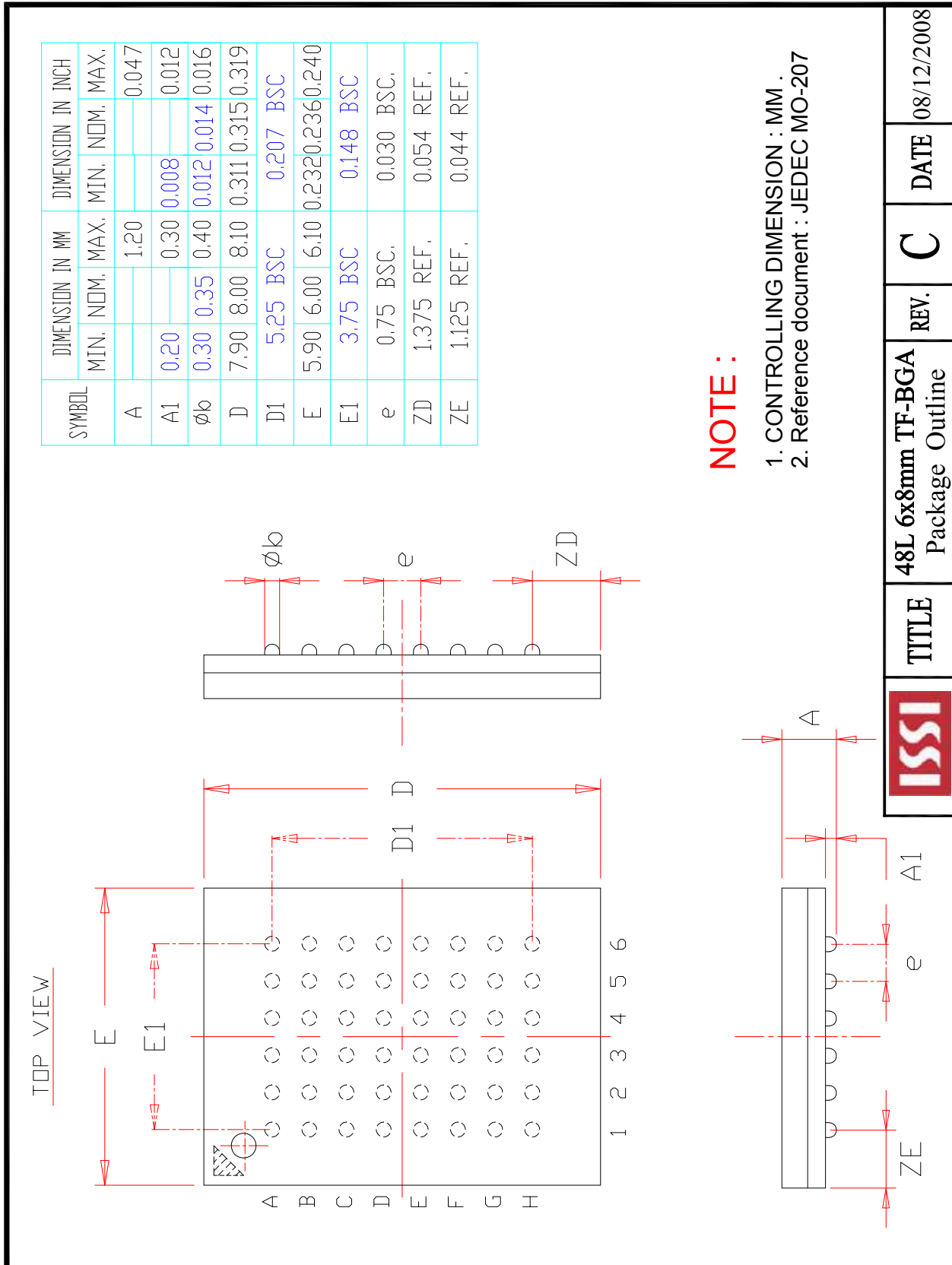

	TITLE	48L 6x8mm TF-BGA Package Outline	REV.	C	DATE	08/12/2008
---	--------------	-------------------------------------	-------------	----------	-------------	------------

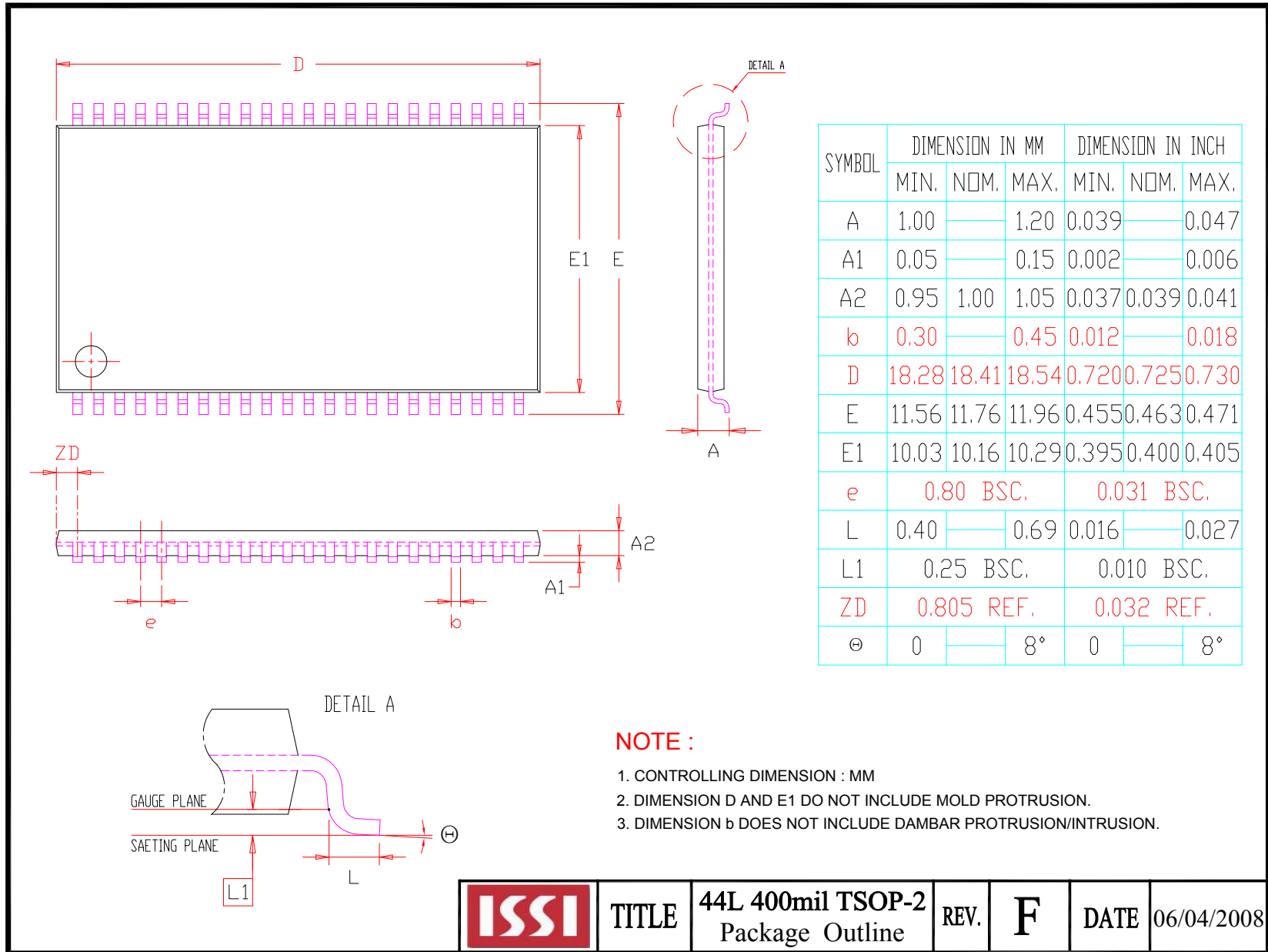

ISSI	TITLE	44L 400mil TSOP-2 Package Outline	REV.	F	DATE	06/04/2008
-------------	--------------	--	-------------	----------	-------------	-------------------

