

## 256Kx16 4Mb DRAM WITH EDO PAGE MODE

JANUARY 2013

### FEATURES

- TTL compatible inputs and outputs; tri-state I/O
- Refresh Interval: 512 cycles/8 ms
- Refresh Mode :  $\overline{\text{RAS}}$ -Only,  $\overline{\text{CAS}}$ -before- $\overline{\text{RAS}}$  (CBR), and Hidden
- JEDEC standard pinout
- Single power supply:  
5V  $\pm$  10% (IS41C16256C)  
3.3V  $\pm$  10% (IS41LV16256C)
- Byte Write and Byte Read operation via two  $\overline{\text{CAS}}$
- Industrial Temperature Range -40°C to +85°C

### DESCRIPTION

The IS41C16256C and IS41LV16256C are 262,144 x 16-bit high-performance CMOS Dynamic Random Access Memories. Both products offer accelerated cycle access EDO Page Mode. EDO Page Mode allows 512 random accesses within a single row with access cycle time as short as 14ns per 16-bit word. It is asynchronous, as it does not require a clock signal input to synchronize commands and I/O.

These features make the IS41C/LV16256C ideally suited for high band-width graphics, digital signal processing, high-performance computing systems, and peripheral applications that run without a clock to synchronize with the DRAM.

The IS41C/LV16256C is packaged in 40-pin TSOP (Type II).

### KEY TIMING PARAMETERS

Parameter	-35	Unit
Max. $\overline{\text{RAS}}$ Access Time ( $t_{\text{RAC}}$ )	35	ns
Max. $\overline{\text{CAS}}$ Access Time ( $t_{\text{CAC}}$ )	13	ns
Max. Column Address Access Time ( $t_{\text{AA}}$ )	18	ns
Min. EDO Page Mode Cycle Time ( $t_{\text{PC}}$ )	14	ns
Min. Read/Write Cycle Time ( $t_{\text{RC}}$ )	60	ns

Copyright © 2013 Integrated Silicon Solution, Inc. All rights reserved. ISSI reserves the right to make changes to this specification and its products at any time without notice. ISSI assumes no liability arising out of the application or use of any information, products or services described herein. Customers are advised to obtain the latest version of this device specification before relying on any published information and before placing orders for products.

Integrated Silicon Solution, Inc. does not recommend the use of any of its products in life support applications where the failure or malfunction of the product can reasonably be expected to cause failure of the life support system or to significantly affect its safety or effectiveness. Products are not authorized for use in such applications unless Integrated Silicon Solution, Inc. receives written assurance to its satisfaction, that:

- a.) the risk of injury or damage has been minimized;
- b.) the user assume all such risks; and
- c.) potential liability of Integrated Silicon Solution, Inc is adequately protected under the circumstances

**PIN CONFIGURATIONS**  
**40-Pin TSOP (Type II)**

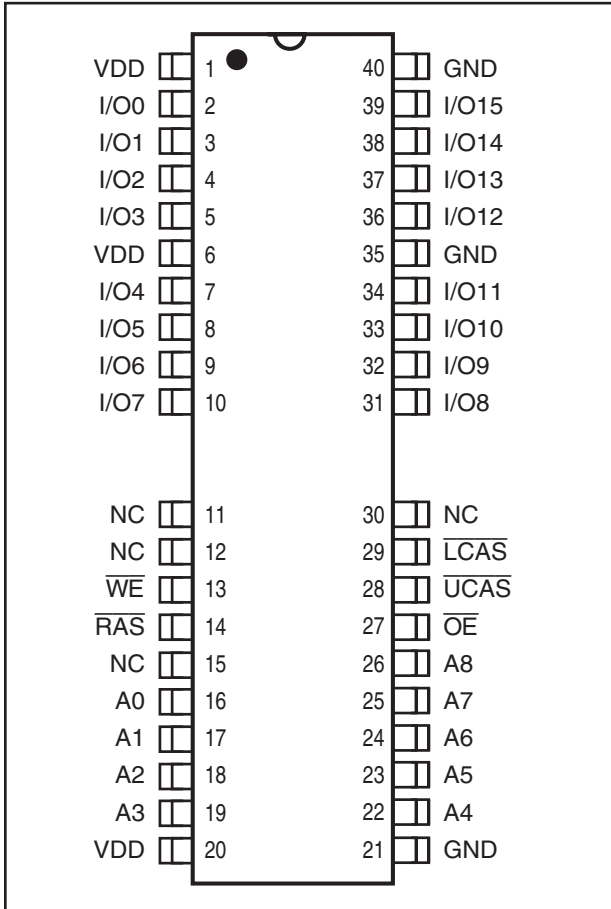

**PIN DESCRIPTIONS**

A0-A8	Address Inputs
I/O0-15	Data Inputs/Outputs
$\overline{WE}$	Write Enable
$\overline{OE}$	Output Enable
$\overline{RAS}$	Row Address Strobe
$\overline{UCAS}$	Upper Column Address Strobe
$\overline{LCAS}$	Lower Column Address Strobe
V <sub>DD</sub>	Power
GND	Ground
NC	No Connection

FUNCTIONAL BLOCK DIAGRAM

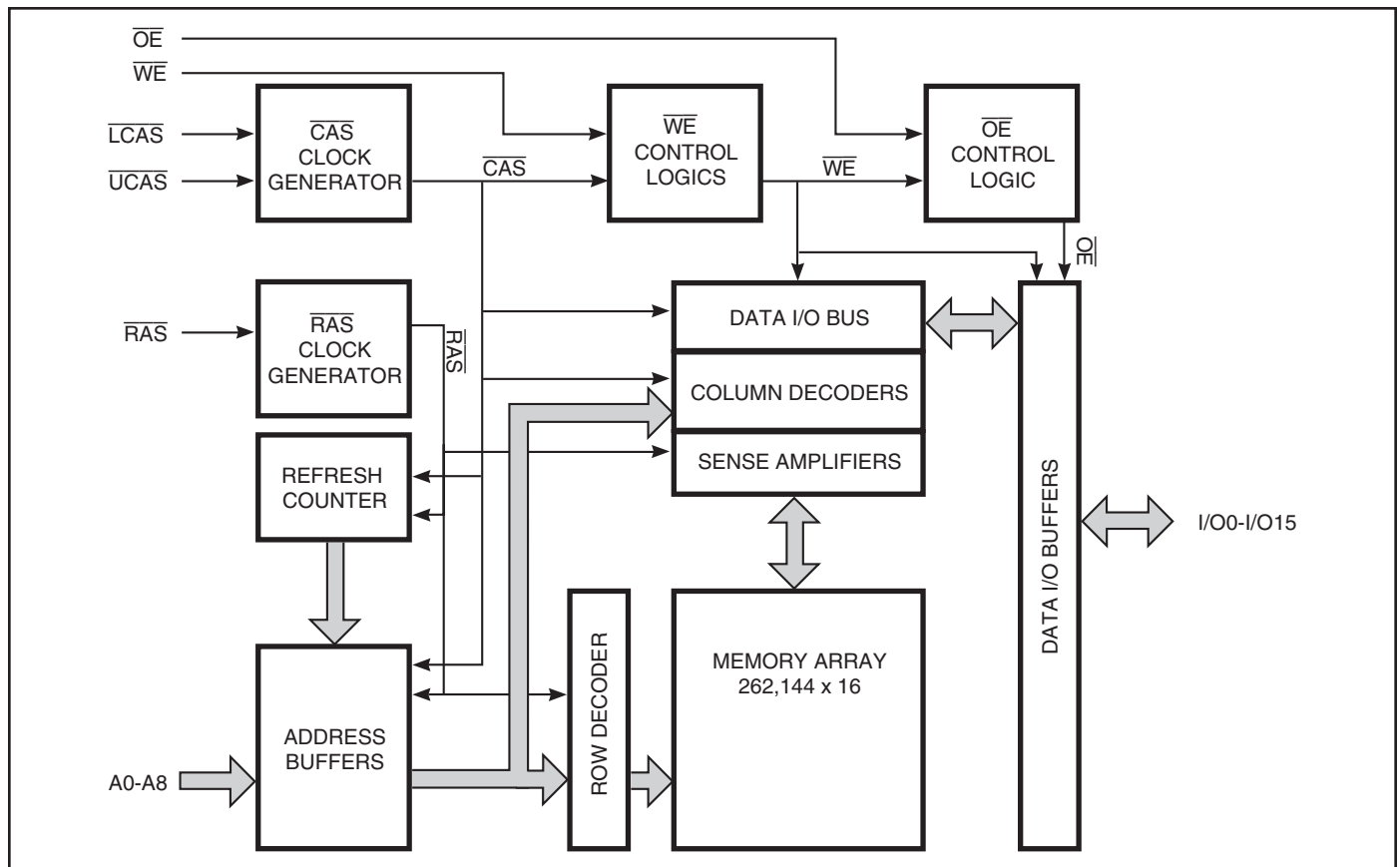

TRUTH TABLE<sup>(5)</sup>

Function		$\overline{\text{RAS}}$	$\overline{\text{LCAS}}$	$\overline{\text{UCAS}}$	$\overline{\text{WE}}$	$\overline{\text{OE}}$	Address tr/tc	I/O
Standby		H	X	X	X	X	X	High-Z
Read: Word		L	L	L	H	L	ROW/COL	DOUT
Read: Lower Byte		L	L	H	H	L	ROW/COL	Lower Byte, DOUT Upper Byte, High-Z
Read: Upper Byte		L	H	L	H	L	ROW/COL	Lower Byte, High-Z Upper Byte, DOUT
Write: Word (Early Write)		L	L	L	L	X	ROW/COL	DIN
Write: Lower Byte (Early Write)		L	L	H	L	X	ROW/COL	Lower Byte, DIN Upper Byte, High-Z
Write: Upper Byte (Early Write)		L	H	L	L	X	ROW/COL	Lower Byte, High-Z Upper Byte, DIN
Read-Write <sup>(1,2)</sup>		L	L	L	H→L	L→H	ROW/COL	DOUT, DIN
EDO Page-Mode Read <sup>(2)</sup>	1st Cycle:	L	H→L	H→L	H	L	ROW/COL	DOUT
	2nd Cycle:	L	H→L	H→L	H	L	NA/COL	DOUT
	Any Cycle:	L	L→H	L→H	H	L	NA/NA	DOUT
EDO Page-Mode Write <sup>(1)</sup>	1st Cycle:	L	H→L	H→L	L	X	ROW/COL	DIN
	2nd Cycle:	L	H→L	H→L	L	X	NA/COL	DIN
EDO Page-Mode Read-Write <sup>(1,2)</sup>	1st Cycle:	L	H→L	H→L	H→L	L→H	ROW/COL	DOUT, DIN
	2nd Cycle:	L	H→L	H→L	H→L	L→H	NA/COL	DOUT, DIN
Hidden Refresh	Read <sup>(2)</sup>	L→H→L	L	L	H	L	ROW/COL	DOUT
	Write <sup>(1,3)</sup>	L→H→L	L	L	L	X	ROW/COL	DOUT
$\overline{\text{RAS}}$ -Only Refresh		L	H	H	X	X	ROW/NA	High-Z
CBR Refresh <sup>(4)</sup>		H→L	L	L	H	X	X	High-Z

Notes:

1. These WRITE cycles may also be BYTE WRITE cycles (either  $\overline{\text{LCAS}}$  or  $\overline{\text{UCAS}}$  active).
2. These READ cycles may also be BYTE READ cycles (either  $\overline{\text{LCAS}}$  or  $\overline{\text{UCAS}}$  active).
3. Early write only.
4. At least one of the two  $\overline{\text{CAS}}$  signals must be active ( $\overline{\text{LCAS}}$  or  $\overline{\text{UCAS}}$ ).
5. Commands valid only after proper initialization.

## Functional Description

The IS41C/LV16256C is a CMOS DRAM optimized for high-speed bandwidth, low power applications. During READ or WRITE cycles, each bit is uniquely addressed through the 18 address bits. These are entered nine bits (A0-A8) at a time. The row address is latched by the Row Address Strobe ( $\overline{RAS}$ ). The column address is latched by the Column Address Strobe ( $\overline{CAS}$ ).  $\overline{RAS}$  is used to latch the first nine bits and  $\overline{CAS}$  is used the latter nine bits.

The IS41C/LV16256C has two  $\overline{CAS}$  controls,  $\overline{LCAS}$  and  $\overline{UCAS}$ . The  $\overline{LCAS}$  and  $\overline{UCAS}$  inputs internally generate a  $\overline{CAS}$  signal functioning in an identical manner to the single  $\overline{CAS}$  input on the other 256K x 16 DRAMs. The key difference is that each  $\overline{CAS}$  controls its corresponding I/O tristate logic (in conjunction with  $\overline{OE}$  and  $\overline{WE}$  and  $\overline{RAS}$ ).  $\overline{LCAS}$  controls I/O0 through I/O7 and  $\overline{UCAS}$  controls I/O8 through I/O15.

The IS41C/LV16256C  $\overline{CAS}$  function is determined by the first  $\overline{CAS}$  ( $\overline{LCAS}$  or  $\overline{UCAS}$ ) transitioning LOW and the last transitioning back HIGH. The two  $\overline{CAS}$  controls give the IS41C/LV16256C both BYTE READ and BYTE WRITE cycle capabilities.

## Memory Cycle

A memory cycle is initiated by bring  $\overline{RAS}$  LOW and it is terminated by returning both  $\overline{RAS}$  and  $\overline{CAS}$  HIGH. To ensure proper device operation and data integrity any memory cycle, once initiated, must not be ended or aborted before the minimum  $t_{RAS}$  time has expired. A new cycle must not be initiated until the minimum precharge time  $t_{RP}$ ,  $t_{CP}$  has elapsed.

## Read Cycle

A read cycle is initiated by the falling edge of  $\overline{CAS}$  or  $\overline{OE}$ , whichever occurs last, while holding  $\overline{WE}$  HIGH. The column address must be held for a minimum time specified by  $t_{AR}$ . Data Out becomes valid only when  $t_{RAC}$ ,  $t_{AA}$ ,  $t_{CAC}$  and  $t_{OEA}$  are all satisfied. As a result, the access time is dependent on the timing relationships between these parameters.

## Write Cycle

A write cycle is initiated by the falling edge of  $\overline{CAS}$  and  $\overline{WE}$ , whichever occurs last. The input data must be valid at or before the falling edge of  $\overline{CAS}$  or  $\overline{WE}$ , whichever occurs last.

## Refresh Cycle

To retain data, 512 refresh cycles are required in each 8 ms period. There are two ways to refresh the memory.

1. By clocking each of the 512 row addresses (A0 through A8) with  $\overline{RAS}$  at least once every 8 ms. Any read, write, read-modify-write or  $\overline{RAS}$ -only cycle refreshes the addressed row.
2. Using a  $\overline{CAS}$ -before- $\overline{RAS}$  refresh cycle.  $\overline{CAS}$ -before- $\overline{RAS}$  refresh is activated by the falling edge of  $\overline{RAS}$ , while holding  $\overline{CAS}$  LOW. In  $\overline{CAS}$ -before- $\overline{RAS}$  refresh cycle, an internal 9-bit counter provides the row addresses and the external address inputs are ignored.  $\overline{CAS}$ -before- $\overline{RAS}$  is a refresh-only mode and no data access or device selection is allowed. Thus, the output remains in the High-Z state during the cycle.

## Extended Data Out Page Mode

EDO page mode operation permits all 512 columns within a selected row to be randomly accessed at a high data rate.

In EDO page mode read cycle, the data-out is held to the next  $\overline{CAS}$  cycle's falling edge, instead of the rising edge. For this reason, the valid data output time in EDO page mode is extended compared with the fast page mode. In the fast page mode, the valid data output time becomes shorter as the  $\overline{CAS}$  cycle time becomes shorter. Therefore, in EDO page mode, the timing margin in read cycle is larger than that of the fast page mode even if the  $\overline{CAS}$  cycle time becomes shorter.

In EDO page mode, due to the extended data function, the  $\overline{CAS}$  cycle time can be shorter than in the fast page mode if the timing margin is the same.

The EDO page mode allows both read and write operations during one  $\overline{RAS}$  cycle, but the performance is equivalent to that of the fast page mode in that case.

## Power-On

During Power-on,  $\overline{RAS}$ ,  $\overline{CAS}$ ,  $\overline{UCAS}$ ,  $\overline{LCAS}$ , and  $\overline{WE}$  must all track with  $V_{DD}$  (HIGH) to avoid current surges, and allow initialization to continue. An initial pause of 200  $\mu$ s is required followed by a minimum of eight initialization cycles (any combination of cycles containing a  $\overline{RAS}$  signal).

### ABSOLUTE MAXIMUM RATINGS<sup>(1)</sup>

Symbol	Parameters	Rating	Unit	
V <sub>T</sub>	Voltage on Any Pin Relative to GND	5V	-1.0 to +7.0	V
		3.3V	-0.5 to +4.6	V
V <sub>DD</sub>	Supply Voltage	5V	-1.0 to +7.0	V
		3.3V	-0.5 to +4.6	V
I <sub>OUT</sub>	Output Current	50	mA	
P <sub>D</sub>	Power Dissipation	1	W	
T <sub>A</sub>	Operation Temperature	-40 to +85	°C	
T <sub>STG</sub>	Storage Temperature	-55 to +125	°C	

**Note:**

1. Stress greater than those listed under ABSOLUTE MAXIMUM RATINGS may cause permanent damage to the device. This is a stress rating only and functional operation of the device at these or any other conditions above those indicated in the operational sections of this specification is not implied. Exposure to absolute maximum rating conditions for extended periods may affect reliability.

### RECOMMENDED OPERATING CONDITIONS (Voltages are referenced to GND.)

Symbol	Parameter	Test Conditions	Min.	Typ.	Max.	Unit	
V <sub>DD</sub>	Supply Voltage		5V	4.5	5.0	5.5	V
			3.3V	3.0	3.3	3.6	V
V <sub>IH</sub>	Input High Voltage		5V	2.4	—	V <sub>DD</sub> + 1.0	V
			3.3V	2.0	—	V <sub>DD</sub> + 0.3	V
V <sub>IL</sub>	Input Low Voltage		5V	-1.0	—	0.8	V
			3.3V	-0.3	—	0.8	V
I <sub>IL</sub>	Input Leakage Current	Any input 0V ≤ V <sub>IN</sub> ≤ V <sub>DD</sub> Other inputs not under test = 0V	-5	—	5	µA	
I <sub>IO</sub>	Output Leakage Current	Output is disabled (Hi-Z) 0V ≤ V <sub>OUT</sub> ≤ V <sub>DD</sub>	-5	—	5	µA	
V <sub>OH</sub>	Output High Voltage Level	I <sub>OH</sub> = -5.0 mA	5V	2.4	—	V	
		I <sub>OH</sub> = -2.0 mA	3.3V	2.4	—	V	
V <sub>OL</sub>	Output Low Voltage Level	I <sub>OL</sub> = +4.2 mA	5V	—	0.4	V	
		I <sub>OL</sub> = +2.0 mA	3.3V	—	0.4	V	

### CAPACITANCE<sup>(1,2)</sup>

Symbol	Parameter	Max.	Unit
C <sub>IN1</sub>	Input Capacitance: A0-A8	5	pF
C <sub>IN2</sub>	Input Capacitance: $\overline{\text{RAS}}$ , $\overline{\text{UCAS}}$ , $\overline{\text{LCAS}}$ , $\overline{\text{WE}}$ , $\overline{\text{OE}}$	7	pF
C <sub>IO</sub>	Data Input/Output Capacitance: I/O0-I/O15	7	pF

**Notes:**

1. Tested initially and after any design or process changes that may affect these parameters.
2. Test conditions: T<sub>A</sub> = 25°C, f = 1 MHz,

## ELECTRICAL CHARACTERISTICS<sup>(1)</sup>

(Recommended Operation Conditions unless otherwise noted.)

Symbol	Parameter	Test Condition	V <sub>DD</sub>	Max.	Unit
IDD1	Stand-by Current: TTL	$\overline{\text{RAS}}, \overline{\text{LCAS}}, \overline{\text{UCAS}} \geq V_{IH}$	5V	2	mA
			3.3V	2	mA
IDD2	Stand-by Current: CMOS	$\overline{\text{RAS}}, \overline{\text{LCAS}}, \overline{\text{UCAS}} \geq V_{DD} - 0.2V$	5V	1	mA
			3.3V	1	mA
IDD3	Operating Current: Random Read/Write <sup>(2,3,4)</sup> Average Power Supply Current	$\overline{\text{RAS}}, \overline{\text{LCAS}}, \overline{\text{UCAS}},$ Address Cycling, $t_{RC} = t_{RC}(\text{min.})$	5V	150	mA
			3.3V	90	mA
IDD4	Operating Current: EDO Page Mode <sup>(2,3,4)</sup> Average Power Supply Current	$\overline{\text{RAS}} = V_{IL}, \overline{\text{LCAS}}, \overline{\text{UCAS}},$ Cycling $t_{PC} = t_{PC}(\text{min.})$	5V	60	mA
			3.3V	30	mA
IDD5	Refresh Current: $\overline{\text{RAS}}$ -Only <sup>(2,3)</sup> Average Power Supply Current	$\overline{\text{RAS}}$ Cycling, $\overline{\text{LCAS}}, \overline{\text{UCAS}} \geq V_{IH}$ $t_{RC} = t_{RC}(\text{min.})$	5V	90	mA
			3.3V	60	mA
IDD6	Refresh Current: CBR <sup>(2,3,5)</sup> Average Power Supply Current	$\overline{\text{RAS}}, \overline{\text{LCAS}}, \overline{\text{UCAS}}$ Cycling $t_{RC} = t_{RC}(\text{min.})$	5V	90	mA
			3.3V	60	mA

### Notes:

1. An initial pause of 200  $\mu\text{s}$  is required after power-up followed by eight  $\overline{\text{RAS}}$  refresh cycles ( $\overline{\text{RAS}}$ -Only or CBR) before proper device operation is assured. The eight  $\overline{\text{RAS}}$  cycles wake-up should be repeated any time the  $t_{REF}$  refresh requirement is exceeded.
2. Dependent on cycle rates.
3. Specified values are obtained with minimum cycle time and the output open.
4. Column-address is changed once each EDO page cycle.
5. Enables on-chip refresh and address counters.

**AC CHARACTERISTICS**<sup>(1,2,3,4,5,6)</sup>

(Recommended Operating Conditions unless otherwise noted.)

Symbol	Parameter	-35		Units
		Min.	Max.	
t <sub>RC</sub>	Random READ or WRITE Cycle Time	70	—	ns
t <sub>RAC</sub>	Access Time from $\overline{\text{RAS}}$ <sup>(6, 7)</sup>	35	—	ns
t <sub>CAC</sub>	Access Time from $\overline{\text{CAS}}$ <sup>(6, 8, 15)</sup>	—	13	ns
t <sub>AA</sub>	Access Time from Column-Address <sup>(6)</sup>	—	18	ns
t <sub>RAS</sub>	$\overline{\text{RAS}}$ Pulse Width	35	10K	ns
t <sub>RP</sub>	$\overline{\text{RAS}}$ Precharge Time	25	—	ns
t <sub>CAS</sub>	$\overline{\text{CAS}}$ Pulse Width <sup>(26)</sup>	6	10K	ns
t <sub>CP</sub>	$\overline{\text{CAS}}$ Precharge Time <sup>(9, 25)</sup>	6	—	ns
t <sub>CSH</sub>	$\overline{\text{CAS}}$ Hold Time <sup>(21)</sup>	35	—	ns
t <sub>RCD</sub>	$\overline{\text{RAS}}$ to $\overline{\text{CAS}}$ Delay Time <sup>(10, 20)</sup>	13	22	ns
t <sub>ASR</sub>	Row-Address Setup Time	0	—	ns
t <sub>RAH</sub>	Row-Address Hold Time	6	—	ns
t <sub>ASC</sub>	Column-Address Setup Time <sup>(20)</sup>	0	—	ns
t <sub>CAH</sub>	Column-Address Hold Time <sup>(20)</sup>	6	—	ns
t <sub>AR</sub>	Column-Address Hold Time (referenced to $\overline{\text{RAS}}$ )	30	—	ns
t <sub>RAD</sub>	$\overline{\text{RAS}}$ to Column-Address Delay Time <sup>(11)</sup>	10	20	ns
t <sub>RAL</sub>	Column-Address to $\overline{\text{RAS}}$ Lead Time	18	—	ns
t <sub>RPC</sub>	$\overline{\text{RAS}}$ to $\overline{\text{CAS}}$ Precharge Time	0	—	ns
t <sub>RSH</sub>	$\overline{\text{RAS}}$ Hold Time <sup>(27)</sup>	10	—	ns
t <sub>RHCP</sub>	$\overline{\text{RAS}}$ Hold Time from $\overline{\text{CAS}}$ Precharge	35	—	ns
t <sub>CLZ</sub>	$\overline{\text{CAS}}$ to Output in Low-Z <sup>(15, 29)</sup>	3	—	ns
t <sub>CRP</sub>	$\overline{\text{CAS}}$ to $\overline{\text{RAS}}$ Precharge Time <sup>(21)</sup>	5	—	ns
t <sub>OD</sub>	Output Disable Time <sup>(19, 28, 29)</sup>	3	15	ns
t <sub>OE</sub> / t <sub>OE A</sub>	Output Enable Time <sup>(15, 16)</sup>	0	13	ns
t <sub>OEHC</sub>	$\overline{\text{OE}}$ HIGH Hold Time from $\overline{\text{CAS}}$ HIGH	8	—	ns
t <sub>OE P</sub>	$\overline{\text{OE}}$ HIGH Pulse Width	8	—	ns
t <sub>OE S</sub>	$\overline{\text{OE}}$ LOW to $\overline{\text{CAS}}$ HIGH Setup Time	5	—	ns
t <sub>RCS</sub>	Read Command Setup Time <sup>(17, 20)</sup>	0	—	ns
t <sub>RRH</sub>	Read Command Hold Time (referenced to $\overline{\text{RAS}}$ ) <sup>(12)</sup>	0	—	ns
t <sub>RCH</sub>	Read Command Hold Time (referenced to $\overline{\text{CAS}}$ ) <sup>(12, 17, 21)</sup>	0	—	ns
t <sub>WCH</sub>	Write Command Hold Time <sup>(17, 27)</sup>	5	—	ns
t <sub>WCR</sub>	Write Command Hold Time (referenced to $\overline{\text{RAS}}$ ) <sup>(17)</sup>	30	—	ns



**AC CHARACTERISTICS** (Continued)<sup>(1,2,3,4,5,6)</sup>  
(Recommended Operating Conditions unless otherwise noted.)

Symbol	Parameter	-35		Units
		Min.	Max.	
tWP	Write Command Pulse Width <sup>(17)</sup>	5	—	ns
tWPZ	$\overline{WE}$ Pulse Widths to Disable Outputs	10	—	ns
tRWL	Write Command to $\overline{RAS}$ Lead Time <sup>(17)</sup>	10	—	ns
tcWL	Write Command to $\overline{CAS}$ Lead Time <sup>(17, 21)</sup>	8	—	ns
twCS	Write Command Setup Time <sup>(14, 17, 20)</sup>	0	—	ns
tDHR	Data-in Hold Time (referenced to $\overline{RAS}$ )	30	—	ns
tACH	Column-Address Setup Time to $\overline{CAS}$ Precharge during WRITE Cycle	15	—	ns
toEH	$\overline{OE}$ Hold Time from $\overline{WE}$ during READ-MODIFY-WRITE cycle <sup>(18)</sup>	8	—	ns
tdS	Data-In Setup Time <sup>(15, 22)</sup>	0	—	ns
tdH	Data-In Hold Time <sup>(15, 22)</sup>	6	—	ns
tRWC	READ-MODIFY-WRITE Cycle Time	80	—	ns
tRWD	$\overline{RAS}$ to $\overline{WE}$ Delay Time during READ-MODIFY-WRITE Cycle <sup>(14)</sup>	46	—	ns
tcWD	$\overline{CAS}$ to $\overline{WE}$ Delay Time <sup>(14, 20)</sup>	25	—	ns
tAWD	Column-Address to $\overline{WE}$ Delay Time <sup>(14)</sup>	30	—	ns
tPC	EDO Page Mode READ or WRITE Cycle Time <sup>(24)</sup>	14	—	ns
tRASP	$\overline{RAS}$ Pulse Width in EDO Page Mode	35	100K	ns
tCPA	Access Time from $\overline{CAS}$ Precharge <sup>(15)</sup>	—	20	ns
tPRWC	EDO Page Mode READ-WRITE Cycle Time <sup>(24)</sup>	45	—	ns
tCOH / tDOH	Data Output Hold after $\overline{CAS}$ LOW	5	—	ns
tOFF	Output Buffer Turn-Off Delay from $\overline{CAS}$ or $\overline{RAS}$ <sup>(13,15,19, 29)</sup>	3	10	ns
tWHZ	Output Disable Delay from $\overline{WE}$	3	10	ns
tCLCH	Last $\overline{CAS}$ going LOW to First $\overline{CAS}$ returning HIGH <sup>(23)</sup>	10	—	ns
tcSR	$\overline{CAS}$ Setup Time (CBR REFRESH) <sup>(30, 20)</sup>	8	—	ns
tCHR	$\overline{CAS}$ Hold Time (CBR REFRESH) <sup>(30, 21)</sup>	8	—	ns
tORD	$\overline{OE}$ Setup Time prior to $\overline{RAS}$ during HIDDEN REFRESH Cycle	0	—	ns
tWRP	$\overline{WE}$ Setup Time (CBR Refresh)	5	—	ns
tWRH	$\overline{WE}$ Hold Time (CBR Refresh)	8	—	ns
tREF	Refresh Period (512 Cycles)	—	8	ns
tr	Transition Time (Rise or Fall) <sup>(2, 3)</sup>	2	50	ns

## AC TEST CONDITIONS

Output load: Two TTL Loads and 100 pF ( $V_{DD} = 5.0V \pm 10\%$ )  
One TTL Load and 50 pF ( $V_{DD} = 3.3V \pm 10\%$ )

Input timing reference levels:  $V_{IH} = 2.4V$ ,  $V_{IL} = 0.8V$  ( $V_{DD} = 5.0V \pm 10\%$ );  
 $V_{IH} = 2.0V$ ,  $V_{IL} = 0.8V$  ( $V_{DD} = 3.3V \pm 10\%$ )

Output timing reference levels:  $V_{OH} = 2.4V$ ,  $V_{OL} = 0.4V$  ( $V_{DD} = 5V \pm 10\%$ ,  $3.3V \pm 10\%$ )

### Notes:

1. An initial pause of 200  $\mu s$  is required after power-up followed by eight  $\overline{RAS}$  refresh cycle ( $\overline{RAS}$ -Only or CBR) before proper device operation is assured. The eight  $\overline{RAS}$  cycles wake-up should be repeated any time the  $t_{REF}$  refresh requirement is exceeded.
2.  $V_{IH}$  (MIN) and  $V_{IL}$  (MAX) are reference levels for measuring timing of input signals. Transition times, are measured between  $V_{IH}$  and  $V_{IL}$  (or between  $V_{IL}$  and  $V_{IH}$ ) and assume to be 1 ns for all inputs.
3. In addition to meeting the transition rate specification, all input signals must transit between  $V_{IH}$  and  $V_{IL}$  (or between  $V_{IL}$  and  $V_{IH}$ ) in a monotonic manner.
4. If  $\overline{CAS}$  and  $\overline{RAS} = V_{IH}$ , data output is High-Z.
5. If  $\overline{CAS} = V_{IL}$ , data output may contain data from the last valid READ cycle.
6. Measured with a load equivalent to one TTL gate and 50 pF.
7. Assumes that  $t_{RCD} \leq t_{RCD} (MAX)$ . If  $t_{RCD}$  is greater than the maximum recommended value shown in this table,  $t_{RAC}$  will increase by the amount that  $t_{RCD}$  exceeds the value shown.
8. Assumes that  $t_{RCD} \geq t_{RCD} (MAX)$ .
9. If  $\overline{CAS}$  is LOW at the falling edge of  $\overline{RAS}$ , data out will be maintained from the previous cycle. To initiate a new cycle and clear the data output buffer,  $\overline{CAS}$  and  $\overline{RAS}$  must be pulsed for  $t_{CP}$ .
10. Operation with the  $t_{RCD} (MAX)$  limit ensures that  $t_{RAC} (MAX)$  can be met.  $t_{RCD} (MAX)$  is specified as a reference point only; if  $t_{RCD}$  is greater than the specified  $t_{RCD} (MAX)$  limit, access time is controlled exclusively by  $t_{CAC}$ .
11. Operation within the  $t_{RAD} (MAX)$  limit ensures that  $t_{RCD} (MAX)$  can be met.  $t_{RAD} (MAX)$  is specified as a reference point only; if  $t_{RAD}$  is greater than the specified  $t_{RAD} (MAX)$  limit, access time is controlled exclusively by  $t_{AA}$ .
12. Either  $t_{RCH}$  or  $t_{RRH}$  must be satisfied for a READ cycle.
13.  $t_{OFF} (MAX)$  defines the time at which the output achieves the open circuit condition; it is not a reference to  $V_{OH}$  or  $V_{OL}$ .
14.  $t_{WCS}$ ,  $t_{RWD}$ ,  $t_{AWD}$  and  $t_{CWD}$  are restrictive operating parameters in LATE WRITE and READ-MODIFY-WRITE cycle only. If  $t_{WCS} \geq t_{WCS} (MIN)$ , the cycle is an EARLY WRITE cycle and the data output will remain open circuit throughout the entire cycle. If  $t_{RWD} \geq t_{RWD} (MIN)$ ,  $t_{AWD} \geq t_{AWD} (MIN)$  and  $t_{CWD} \geq t_{CWD} (MIN)$ , the cycle is a READ-WRITE cycle and the data output will contain data read from the selected cell. If neither of the above conditions is met, the state of I/O (at access time and until  $\overline{CAS}$  and  $\overline{RAS}$  or  $\overline{OE}$  go back to  $V_{IH}$ ) is indeterminate.  $\overline{OE}$  held HIGH and  $\overline{WE}$  taken LOW after  $\overline{CAS}$  goes LOW result in a LATE WRITE ( $\overline{OE}$ -controlled) cycle.
15. Output parameter (I/O) is referenced to corresponding  $\overline{CAS}$  input, I/O0-I/O7 by  $\overline{LCAS}$  and I/O8-I/O15 by  $\overline{UCAS}$ .
16. During a READ cycle, if  $\overline{OE}$  is LOW then taken HIGH before  $\overline{CAS}$  goes HIGH, I/O goes open. If  $\overline{OE}$  is tied permanently LOW, a LATE WRITE or READ-MODIFY-WRITE is not possible.
17. Write command is defined as  $\overline{WE}$  going low.
18. LATE WRITE and READ-MODIFY-WRITE cycles must have both  $t_{OD}$  and  $t_{OEH}$  met ( $\overline{OE}$  HIGH during WRITE cycle) in order to ensure that the output buffers will be open during the WRITE cycle. The I/Os will provide the previously written data if  $\overline{CAS}$  remains LOW and  $\overline{OE}$  is taken back to LOW after  $t_{OEH}$  is met.
19. The I/Os are in open during READ cycles once  $t_{OD}$  or  $t_{OFF}$  occur.
20. The first  $\chi\overline{CAS}$  edge to transition LOW.
21. The last  $\chi\overline{CAS}$  edge to transition HIGH.
22. These parameters are referenced to  $\overline{CAS}$  leading edge in EARLY WRITE cycles and  $\overline{WE}$  leading edge in LATE WRITE or READ-MODIFY-WRITE cycles.
23. Last falling  $\chi\overline{CAS}$  edge to first rising  $\chi\overline{CAS}$  edge.
24. Last rising  $\chi\overline{CAS}$  edge to next cycle's last rising  $\chi\overline{CAS}$  edge.
25. Last rising  $\chi\overline{CAS}$  edge to first falling  $\chi\overline{CAS}$  edge.
26. Each  $\chi\overline{CAS}$  must meet minimum pulse width.
27. Last  $\chi\overline{CAS}$  to go LOW.
28. I/Os controlled, regardless  $\overline{UCAS}$  and  $\overline{LCAS}$ .
29. The 3 ns minimum is a parameter guaranteed by design.
30. Enables on-chip refresh and address counters.

READ CYCLE

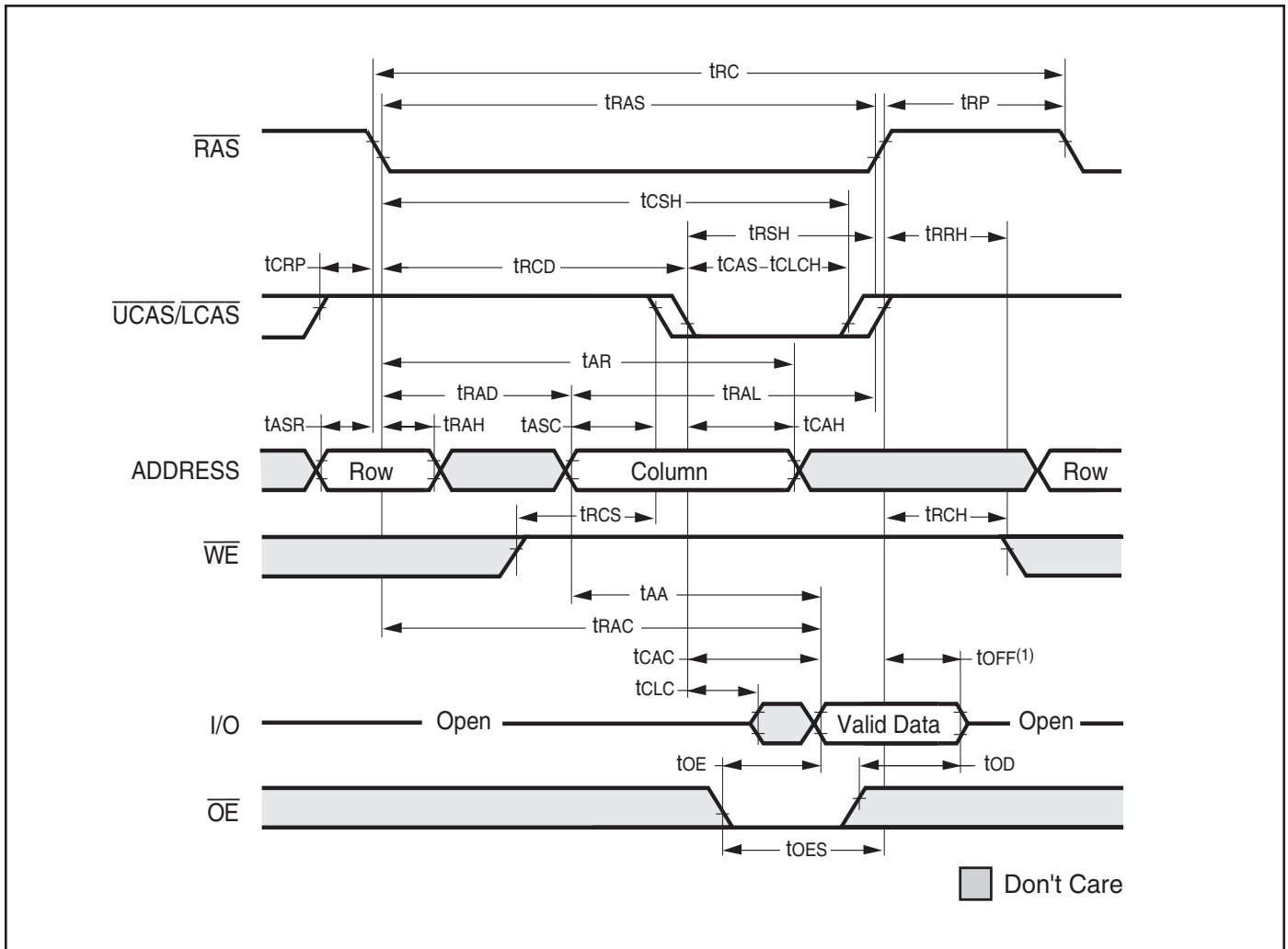

**Note:**

1.  $t_{OFF}$  is referenced from rising edge of  $\overline{RAS}$  or  $\overline{CAS}$ , whichever occurs last.

EARLY WRITE CYCLE ( $\overline{OE}$  = DON'T CARE)

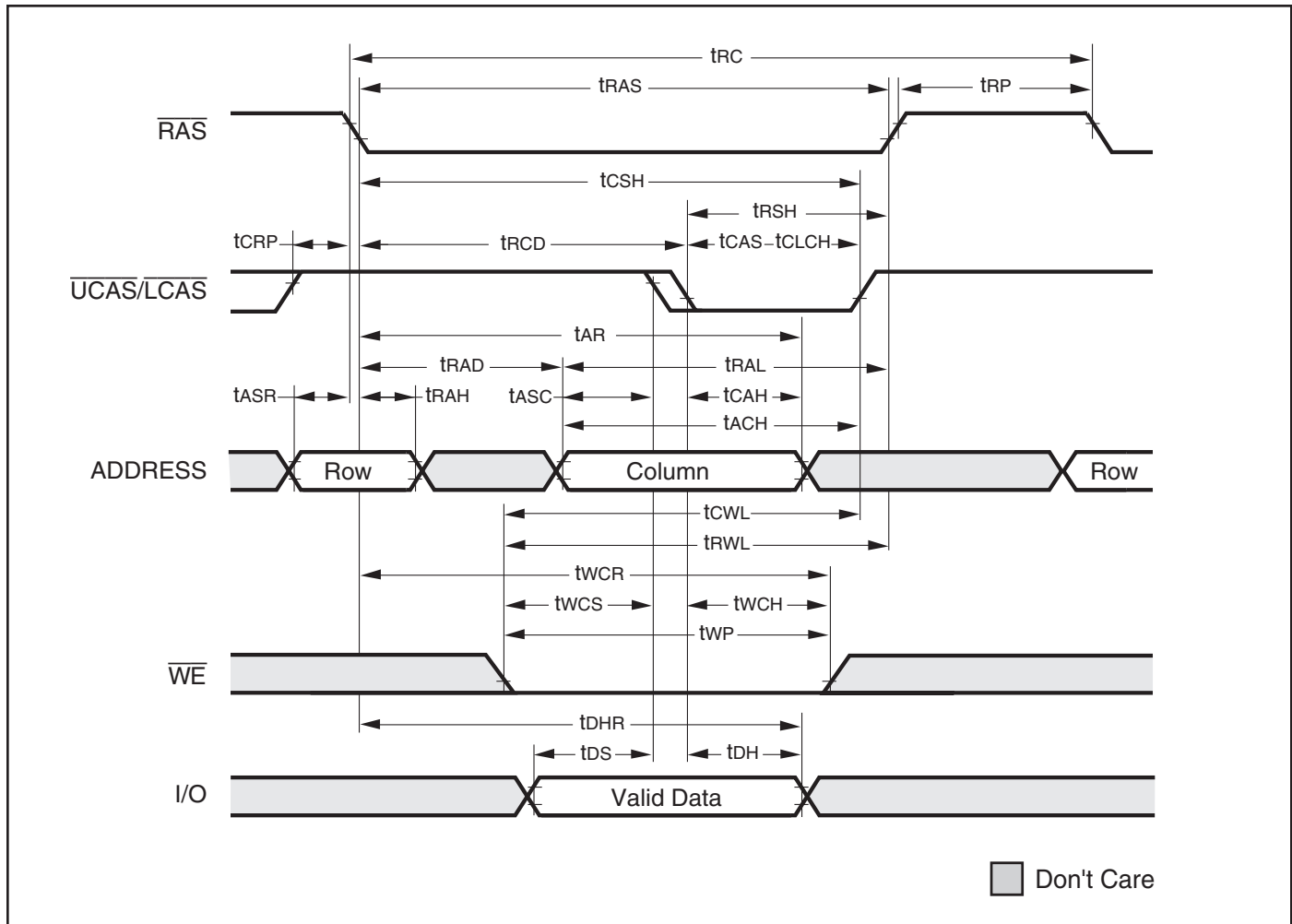

READ WRITE CYCLE (LATE WRITE and READ-MODIFY-WRITE Cycles)

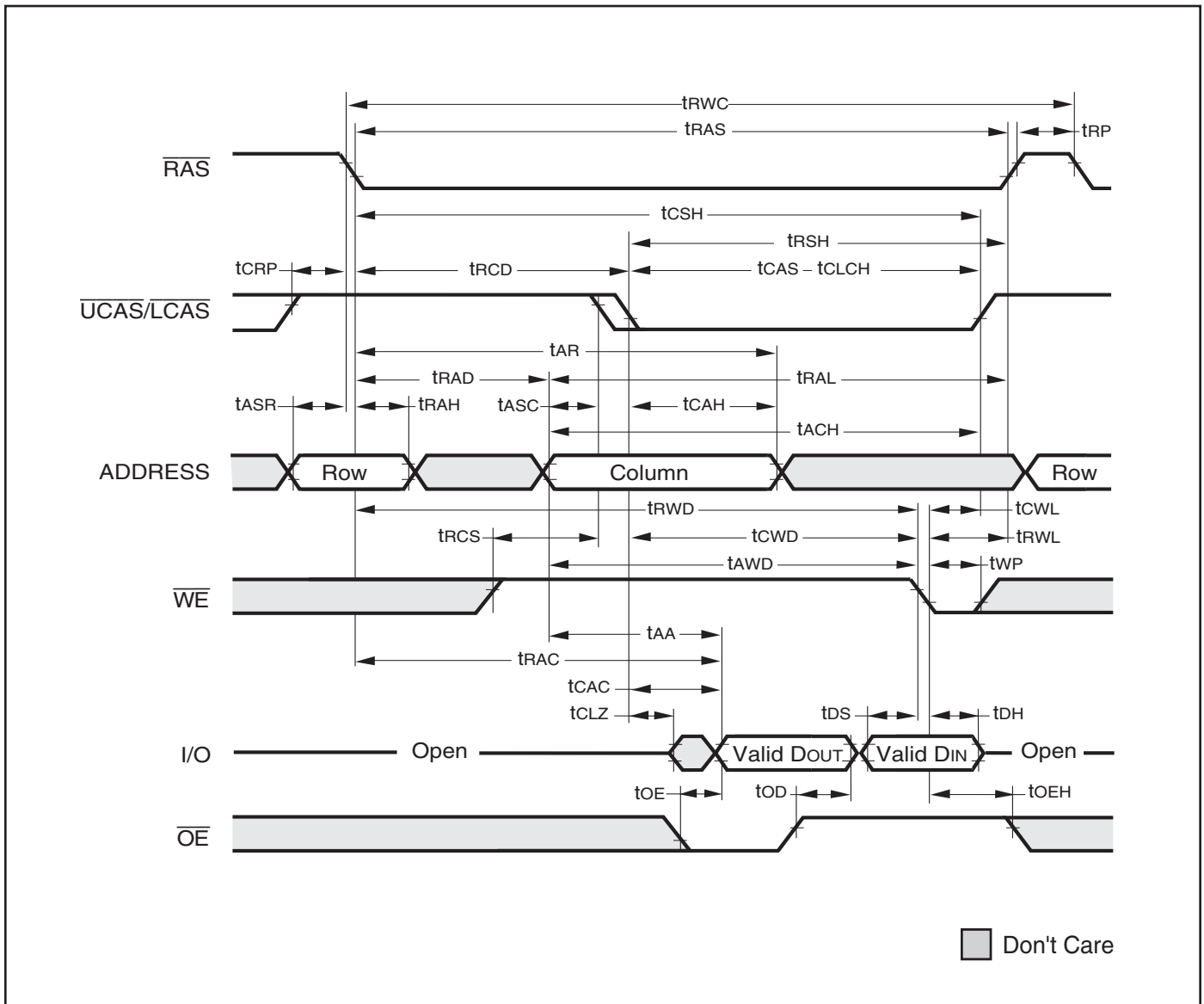

EDO-PAGE-MODE READ CYCLE

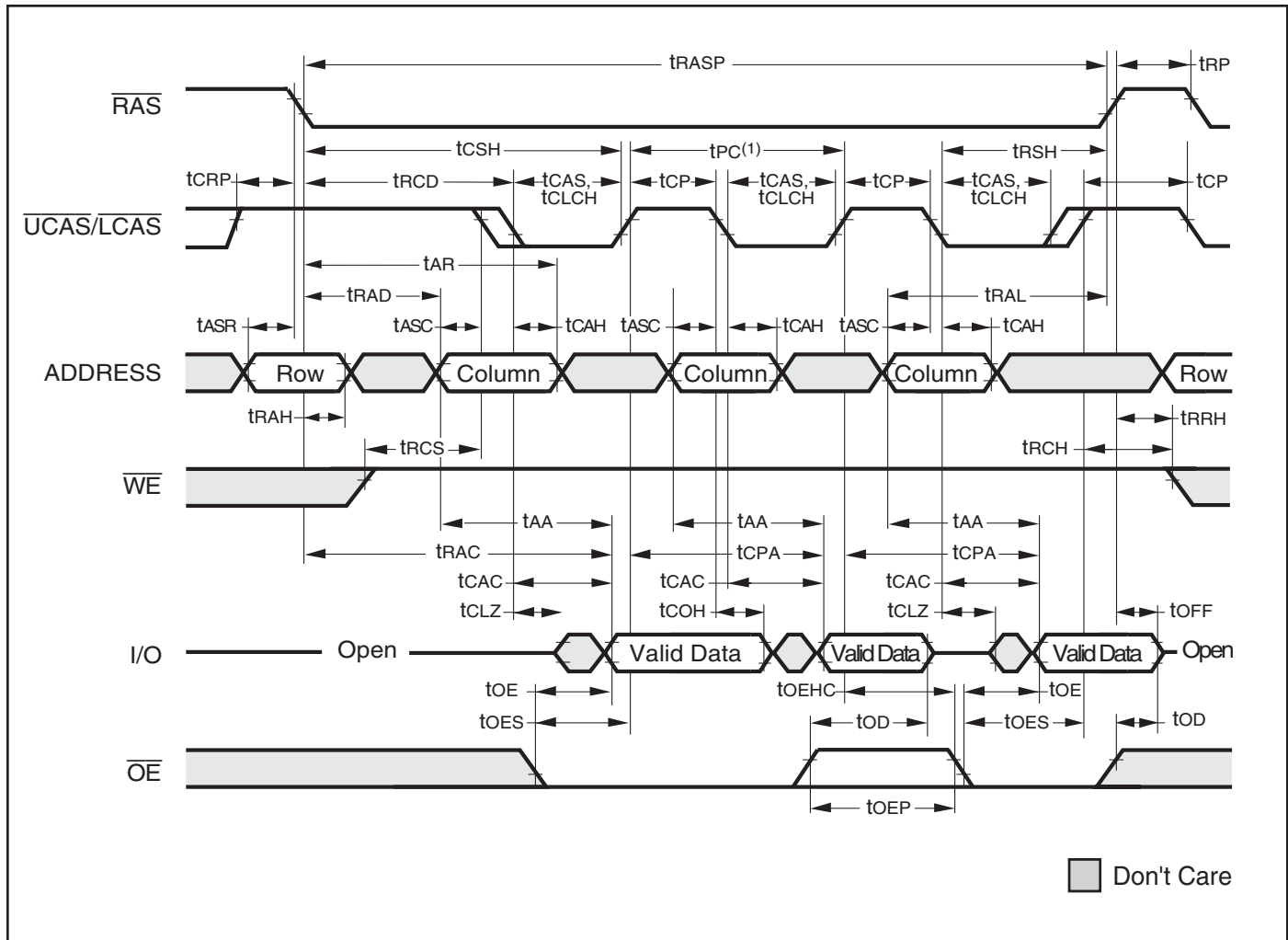

Note:

1.  $t_{\text{PC}}$  can be measured from falling edge of  $\overline{\text{CAS}}$  to falling edge of  $\overline{\text{CAS}}$ , or from rising edge of  $\overline{\text{CAS}}$  to rising edge of  $\overline{\text{CAS}}$ . Both measurements must meet the  $t_{\text{PC}}$  specifications.

EDO-PAGE-MODE EARLY-WRITE CYCLE

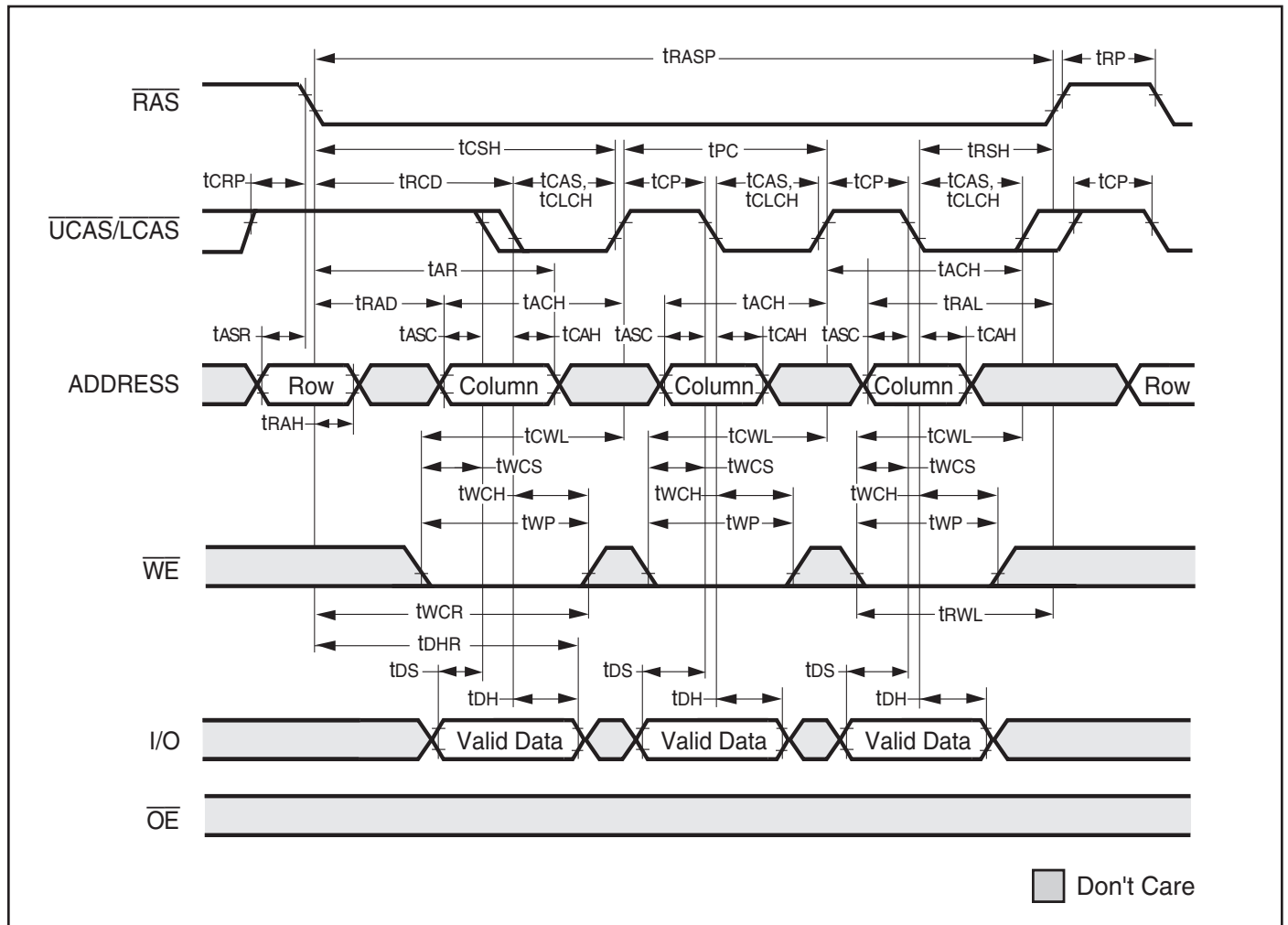





**EDO-PAGE-MODE READ-EARLY-WRITE CYCLE (Pseudo READ-MODIFY WRITE)**

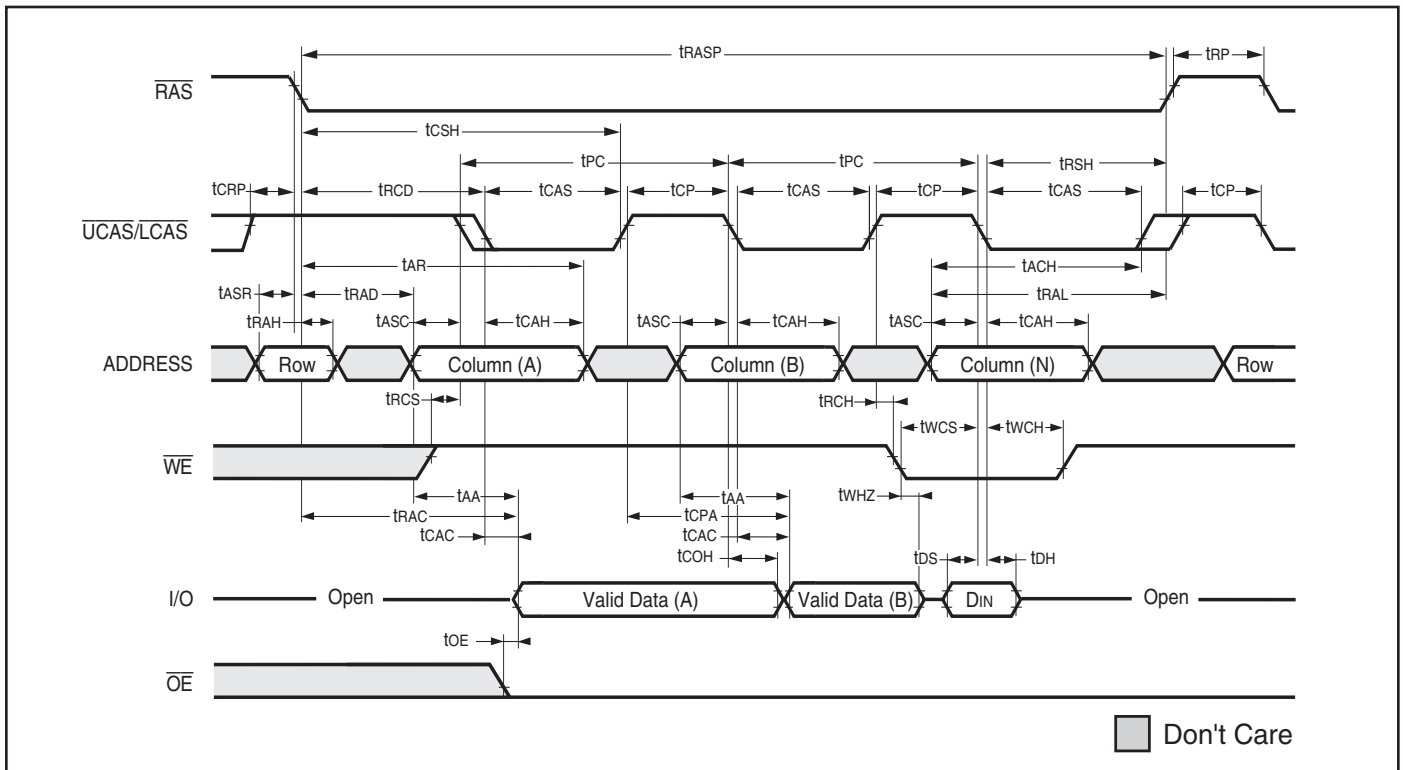

**AC WAVEFORMS**  
**READ CYCLE (With  $\overline{WE}$ -Controlled Disable)**

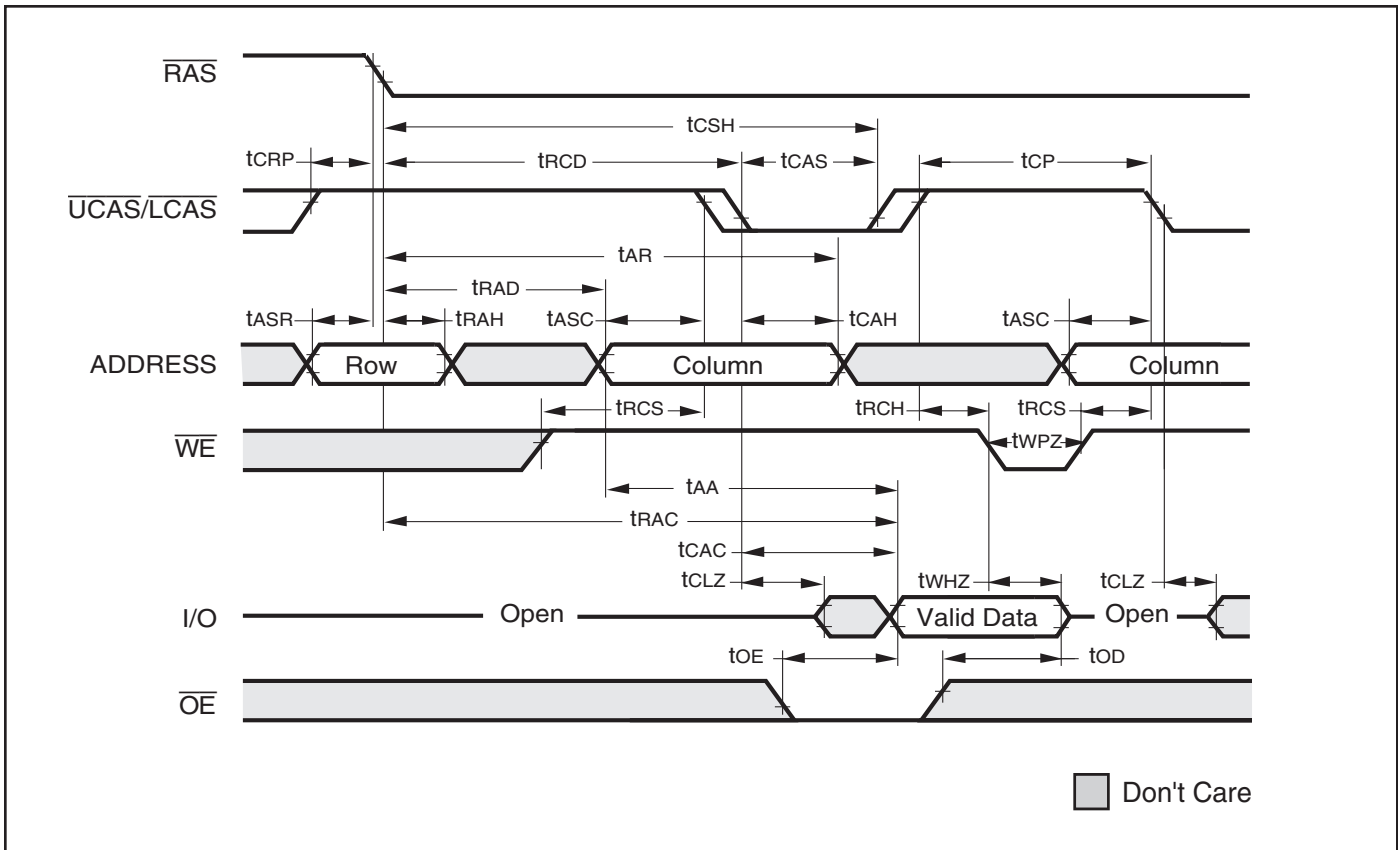

**$\overline{RAS}$ -ONLY REFRESH CYCLE ( $\overline{OE}$ ,  $\overline{WE}$  = DON'T CARE)**

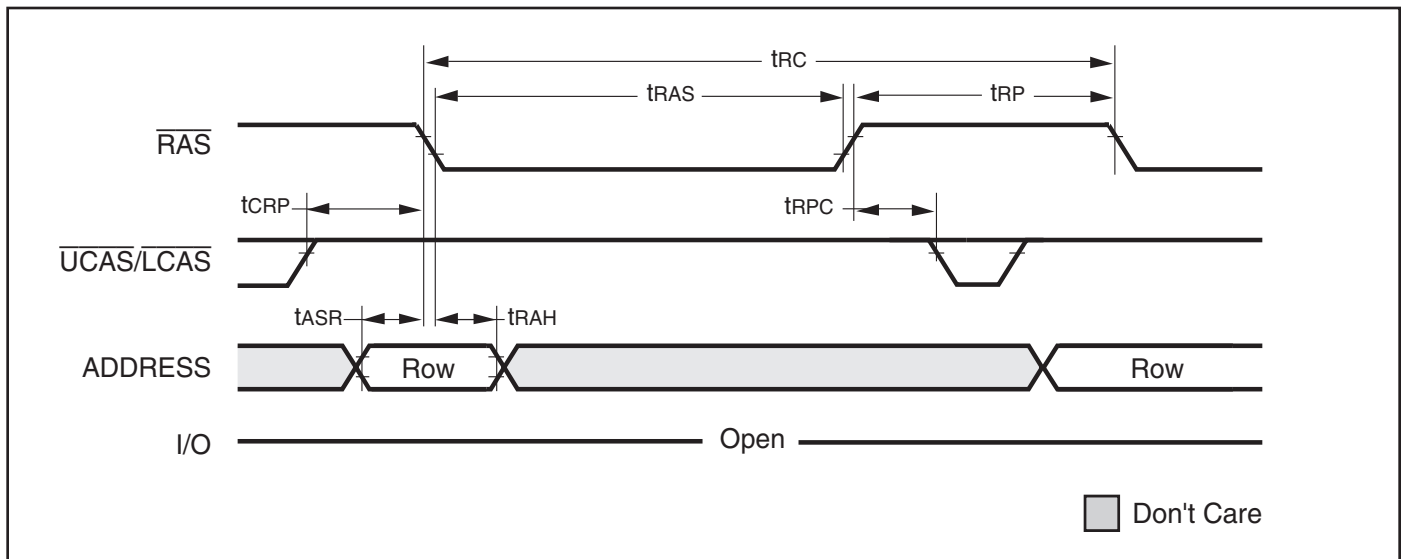

**$\overline{\text{CBR}}$  REFRESH CYCLE (Addresses;  $\overline{\text{OE}}$  = DON'T CARE)**

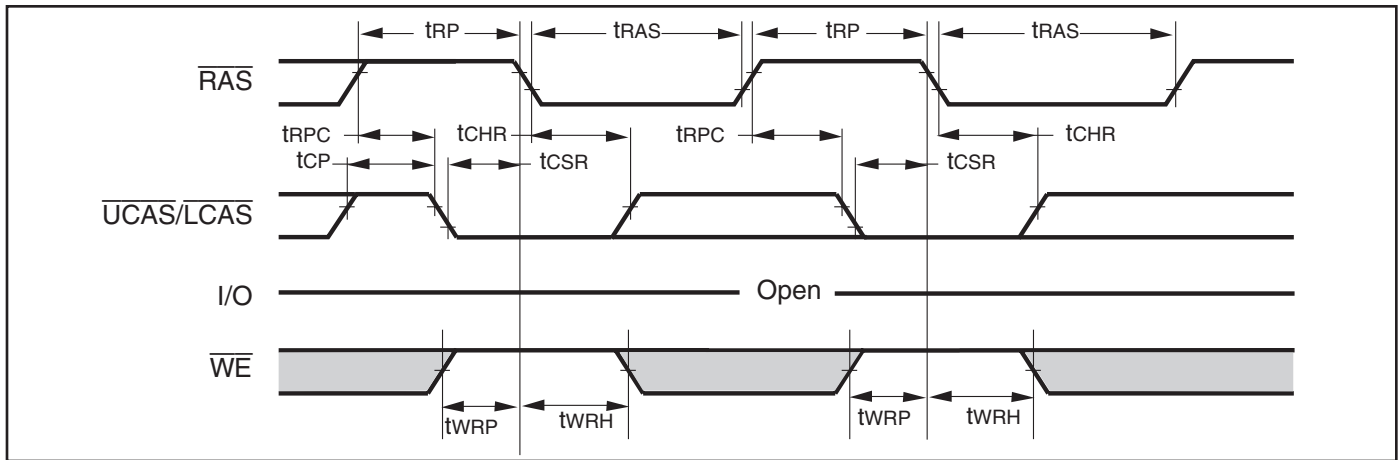

**HIDDEN REFRESH CYCLE ( $\overline{\text{WE}}$  = HIGH;  $\overline{\text{OE}}$  = LOW)<sup>(1)</sup>**

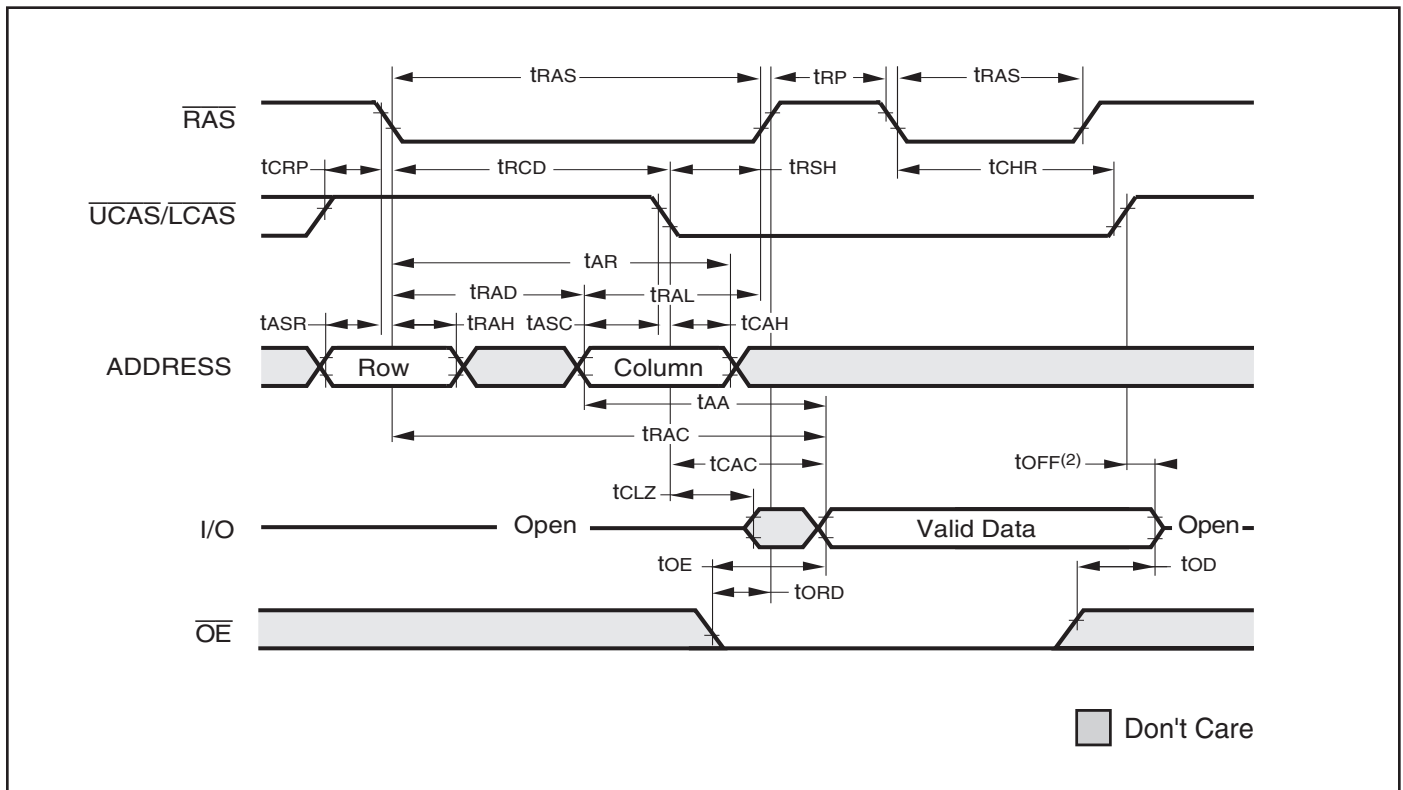

**Notes:**

1. A Hidden Refresh may also be performed after a Write Cycle. In this case,  $\overline{\text{WE}}$  = LOW and  $\overline{\text{OE}}$  = HIGH.
2. tOFF is referenced from rising edge of RAS or CAS, whichever occurs last.

**ORDERING INFORMATION : 3.3V**

**Industrial Range: -40°C to +85°C**

Speed (ns)	Order Part No.	Package
35	IS41LV16256C-35TI	400-mil TSOP (Type II)
	IS41LV16256C-35TLI	400-mil TSOP (Type II), Lead-free

**ORDERING INFORMATION : 5V**

**Industrial Range: -40°C to +85°C**

Speed (ns)	Order Part No.	Package
35	IS41C16256C-35TI	400-mil TSOP (Type II)
	IS41C16256C-35TLI	400-mil TSOP (Type II), Lead-free

**Note:**

The -35 speed option supports 35ns and 60ns timing specifications.

