

IS41LV16105B

1M x 16 (16-MBIT) DYNAMIC RAM WITH FAST PAGE MODE

APRIL 2005

FEATURES

- TTL compatible inputs and outputs; tristate I/O
- Refresh Interval:
 - 1,024 cycles/16 ms
- Refresh Mode:
 - $\overline{\text{RAS}}$ -Only, $\overline{\text{CAS}}$ -before- $\overline{\text{RAS}}$ (CBR), and Hidden
- JEDEC standard pinout
- Single power supply: $3.3\text{V} \pm 10\%$
- Byte Write and Byte Read operation via two $\overline{\text{CAS}}$
- Extended Temperature Range: -30°C to $+85^{\circ}\text{C}$
- Industrial Temperature Range: -40°C to $+85^{\circ}\text{C}$
- Lead-free available

DESCRIPTION

The ISSI IS41LV16105B is 1,048,576 x 16-bit high-performance CMOS Dynamic Random Access Memories. Fast Page Mode allows 1,024 random accesses within a single row with access cycle time as short as 20 ns per 16-bit word. The Byte Write control, of upper and lower byte, makes the IS41LV16105B ideal for use in 16-, 32-bit wide data bus systems.

These features make the IS41LV16105B ideally suited for high-bandwidth graphics, digital signal processing, high-performance computing systems, and peripheral applications.

The IS41LV16105B is packaged in a 42-pin 400-mil SOJ and 400-mil 44- (50-) pin TSOP (Type II).

PIN CONFIGURATIONS

44(50)-Pin TSOP (Type II)

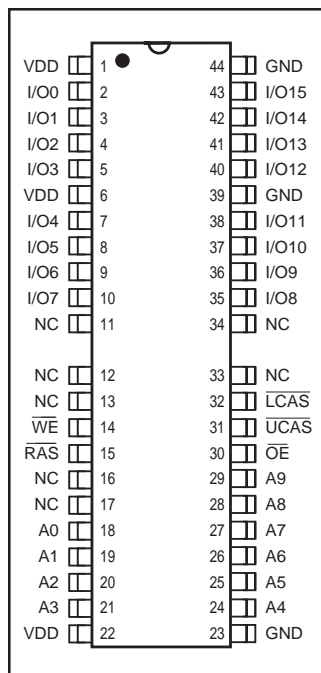

42-Pin SOJ

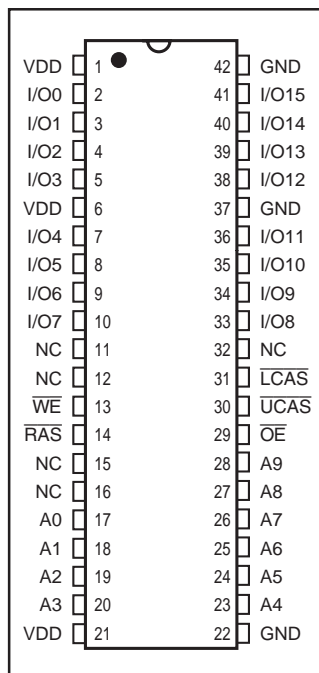

KEY TIMING PARAMETERS

| Parameter | -50 | -60 | Unit |
|---|-----|-----|------|
| Max. $\overline{\text{RAS}}$ Access Time (t_{RAC}) | 50 | 60 | ns |
| Max. $\overline{\text{CAS}}$ Access Time (t_{CAC}) | 13 | 15 | ns |
| Max. Column Address Access Time (t_{AA}) | 25 | 30 | ns |
| Min. Fast Page Mode Cycle Time (t_{PC}) | 20 | 25 | ns |
| Min. Read/Write Cycle Time (t_{RC}) | 84 | 104 | ns |

PIN DESCRIPTIONS

| | |
|--------------------------|-----------------------------|
| A0-A9 | Address Inputs |
| I/O0-15 | Data Inputs/Outputs |
| $\overline{\text{WE}}$ | Write Enable |
| $\overline{\text{OE}}$ | Output Enable |
| $\overline{\text{RAS}}$ | Row Address Strobe |
| $\overline{\text{UCAS}}$ | Upper Column Address Strobe |
| $\overline{\text{LCAS}}$ | Lower Column Address Strobe |
| VDD | Power |
| GND | Ground |
| NC | No Connection |

Copyright © 2005 Integrated Silicon Solution, Inc. All rights reserved. ISSI reserves the right to make changes to this specification and its products at any time without notice. ISSI assumes no liability arising out of the application or use of any information, products or services described herein. Customers are advised to obtain the latest version of this device specification before relying on any published information and before placing orders for products.

FUNCTIONAL BLOCK DIAGRAM

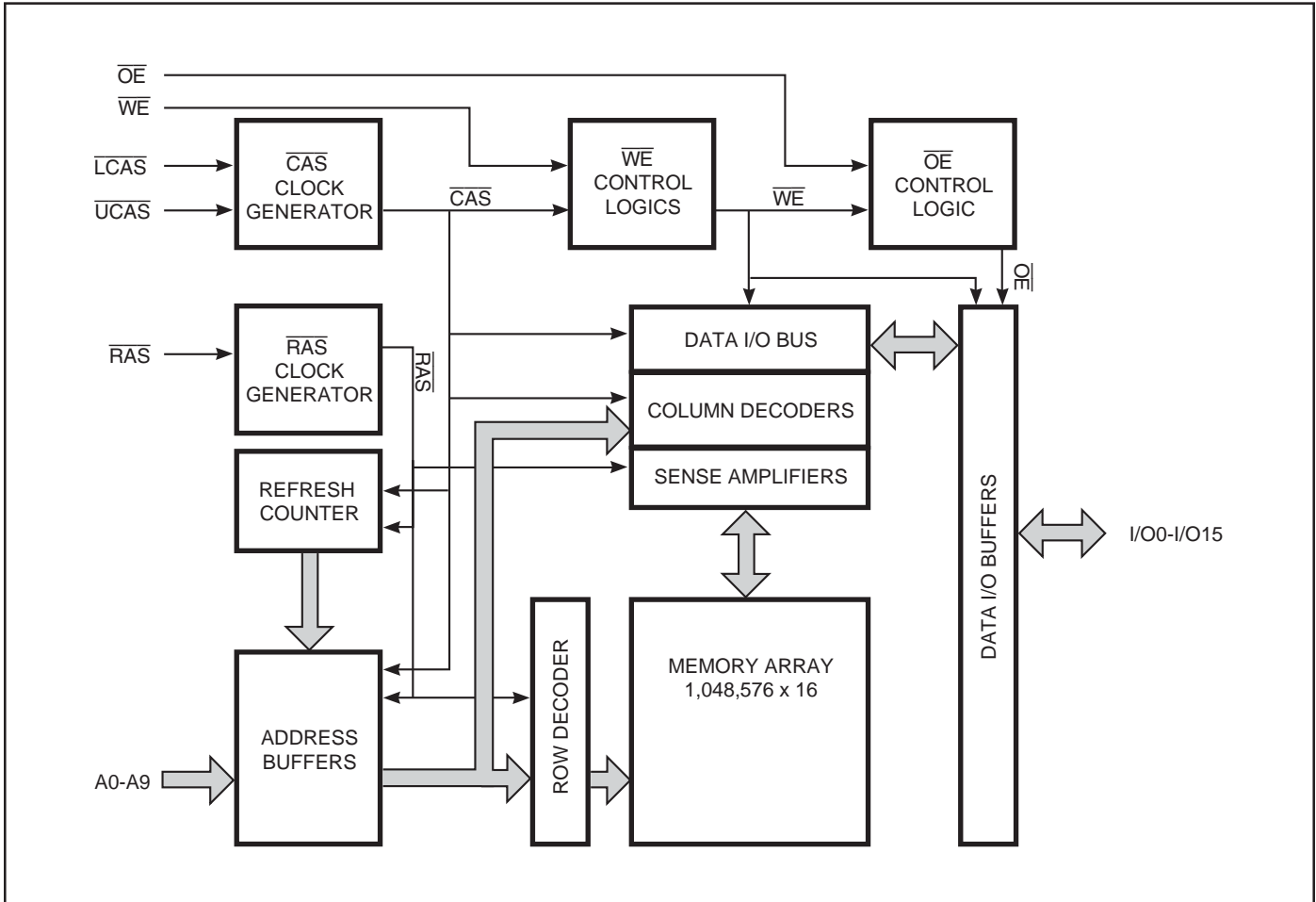

TRUTH TABLE

| Function | $\overline{\text{RAS}}$ | $\overline{\text{LCAS}}$ | $\overline{\text{UCAS}}$ | $\overline{\text{WE}}$ | $\overline{\text{OE}}$ | Address tr/tc | I/O | |
|---------------------------------------|-------------------------|--------------------------|--------------------------|------------------------|------------------------|---------------|--|------------------|
| Standby | H | H | H | X | X | X | High-Z | |
| Read: Word | L | L | L | H | L | ROW/COL | D _{OUT} | |
| Read: Lower Byte | L | L | H | H | L | ROW/COL | Lower Byte, D _{OUT} Upper Byte, High-Z | |
| Read: Upper Byte | L | H | L | H | L | ROW/COL | Lower Byte, High-Z Upper Byte, D _{OUT} | |
| Write: Word (Early Write) | L | L | L | L | X | ROW/COL | D _{IN} | |
| Write: Lower Byte (Early Write) | L | L | H | L | X | ROW/COL | Lower Byte, D _{IN} Upper Byte, High-Z | |
| Write: Upper Byte (Early Write) | L | H | L | L | X | ROW/COL | Lower Byte, High-Z Upper Byte, D _{IN} | |
| Read-Write ^(1,2) | L | L | L | H→L | L→H | ROW/COL | D _{OUT} , D _{IN} | |
| Hidden Refresh | Read ⁽²⁾ | L→H→L | L | L | H | L | ROW/COL | D _{OUT} |
| | Write ^(1,3) | L→H→L | L | L | L | X | ROW/COL | D _{OUT} |
| $\overline{\text{RAS}}$ -Only Refresh | L | H | H | X | X | ROW/NA | High-Z | |
| CBR Refresh ⁽⁴⁾ | H→L | L | L | X | X | X | High-Z | |

Notes:

1. These WRITE cycles may also be BYTE WRITE cycles (either $\overline{\text{LCAS}}$ or $\overline{\text{UCAS}}$ active).
2. These READ cycles may also be BYTE READ cycles (either $\overline{\text{LCAS}}$ or $\overline{\text{UCAS}}$ active).
3. EARLY WRITE only.
4. At least one of the two $\overline{\text{CAS}}$ signals must be active ($\overline{\text{LCAS}}$ or $\overline{\text{UCAS}}$).

Functional Description

The IS41LV16105B is a CMOS DRAM optimized for high-speed bandwidth, low power applications. During READ or WRITE cycles, each bit is uniquely addressed through the 16 address bits. These are entered ten bits (A0-A9) at a time. The row address is latched by the Row Address Strobe ($\overline{\text{RAS}}$). The column address is latched by the Column Address Strobe ($\overline{\text{CAS}}$). $\overline{\text{RAS}}$ is used to latch the first nine bits and $\overline{\text{CAS}}$ is used the latter nine bits.

The IS41LV16105B has two $\overline{\text{CAS}}$ controls, $\overline{\text{LCAS}}$ and $\overline{\text{UCAS}}$. The $\overline{\text{LCAS}}$ and $\overline{\text{UCAS}}$ inputs internally generates a $\overline{\text{CAS}}$ signal functioning in an identical manner to the single $\overline{\text{CAS}}$ input on the other 1Mx16 DRAMs. The key difference is that each $\overline{\text{CAS}}$ controls its corresponding I/O tristate logic (in conjunction with $\overline{\text{OE}}$ and $\overline{\text{WE}}$ and $\overline{\text{RAS}}$). $\overline{\text{LCAS}}$ controls I/O0 through I/O7 and $\overline{\text{UCAS}}$ controls I/O8 through I/O15.

The IS41LV16105B $\overline{\text{CAS}}$ function is determined by the first $\overline{\text{CAS}}$ ($\overline{\text{LCAS}}$ or $\overline{\text{UCAS}}$) transitioning LOW and the last transitioning back HIGH. The two $\overline{\text{CAS}}$ controls give the IS41LV16105B both BYTE READ and BYTE WRITE cycle capabilities.

Memory Cycle

A memory cycle is initiated by bring $\overline{\text{RAS}}$ LOW and it is terminated by returning both $\overline{\text{RAS}}$ and $\overline{\text{CAS}}$ HIGH. To ensure proper device operation and data integrity any memory cycle, once initiated, must not be ended or aborted before the minimum t_{RAS} time has expired. A new cycle must not be initiated until the minimum precharge time t_{RP} , t_{CP} has elapsed.

Read Cycle

A read cycle is initiated by the falling edge of $\overline{\text{CAS}}$ or $\overline{\text{OE}}$, whichever occurs last, while holding $\overline{\text{WE}}$ HIGH. The column address must be held for a minimum time specified by t_{AR} . Data Out becomes valid only when t_{RAC} , t_{AA} , t_{CAC} and t_{OEA} are all satisfied. As a result, the access time is dependent on the timing relationships between these parameters.

Write Cycle

A write cycle is initiated by the falling edge of $\overline{\text{CAS}}$ and $\overline{\text{WE}}$, whichever occurs last. The input data must be valid at or before the falling edge of $\overline{\text{CAS}}$ or $\overline{\text{WE}}$, whichever occurs last.

Refresh Cycle

To retain data, 1,024 refresh cycles are required in each 16 ms period. There are two ways to refresh the memory.

1. By clocking each of the 1,024 row addresses (A0 through A9) with $\overline{\text{RAS}}$ at least once every 16 ms. Any read, write, read-modify-write or $\overline{\text{RAS}}$ -only cycle refreshes the addressed row.
2. Using a $\overline{\text{CAS}}$ -before- $\overline{\text{RAS}}$ refresh cycle. $\overline{\text{CAS}}$ -before- $\overline{\text{RAS}}$ refresh is activated by the falling edge of $\overline{\text{RAS}}$, while holding $\overline{\text{CAS}}$ LOW. In $\overline{\text{CAS}}$ -before- $\overline{\text{RAS}}$ refresh cycle, an internal 9-bit counter provides the row addresses and the external address inputs are ignored.

$\overline{\text{CAS}}$ -before- $\overline{\text{RAS}}$ is a refresh-only mode and no data access or device selection is allowed. Thus, the output remains in the High-Z state during the cycle.

Power-On

After application of the V_{DD} supply, an initial pause of 200 μs is required followed by a minimum of eight initialization cycles (any combination of cycles containing a $\overline{\text{RAS}}$ signal).

During power-on, it is recommended that $\overline{\text{RAS}}$ track with V_{DD} or be held at a valid V_{IH} to avoid current surges.

ABSOLUTE MAXIMUM RATINGS⁽¹⁾

| Symbol | Parameters | Rating | Unit |
|------------------|------------------------------------|-------------|----------------|
| V _T | Voltage on Any Pin Relative to GND | 3.3V | -0.5 to +4.6 V |
| V _{DD} | Supply Voltage | 3.3V | -0.5 to +4.6 V |
| I _{OUT} | Output Current | 50 | mA |
| P _D | Power Dissipation | 1 | W |
| T _A | Commercial Operation Temperature | 0 to +70 | °C |
| | Extended Temperature | -30 to +85 | °C |
| | Industrial Temperature | -40 to +85 | °C |
| T _{STG} | Storage Temperature | -55 to +125 | °C |

Note:

1. Stress greater than those listed under ABSOLUTE MAXIMUM RATINGS may cause permanent damage to the device. This is a stress rating only and functional operation of the device at these or any other conditions above those indicated in the operational sections of this specification is not implied. Exposure to absolute maximum rating conditions for extended periods may affect reliability.

RECOMMENDED OPERATING CONDITIONS (Voltages are referenced to GND.)

| Symbol | Parameter | Min. | Typ. | Max. | Unit | |
|-----------------|--------------------------------|-------------|------|------|-----------------------|---|
| V _{DD} | Supply Voltage | 3.3V | 3.0 | 3.3 | 3.6 | V |
| V _{IH} | Input High Voltage | 3.3V | 2.0 | — | V _{DD} + 0.3 | V |
| V _{IL} | Input Low Voltage | 3.3V | -0.3 | — | 0.8 | V |
| T _A | Commercial Ambient Temperature | 0 | — | +70 | °C | |
| | Extended Ambient Temperature | -30 | — | +85 | °C | |
| | Industrial Ambient Temperature | -40 | — | +85 | °C | |

CAPACITANCE^(1,2)

| Symbol | Parameter | Max. | Unit |
|------------------|--|------|------|
| C _{IN1} | Input Capacitance: A0-A9 | 5 | pF |
| C _{IN2} | Input Capacitance: $\overline{\text{RAS}}$, $\overline{\text{UCAS}}$, $\overline{\text{LCAS}}$, $\overline{\text{WE}}$, $\overline{\text{OE}}$ | 7 | pF |
| C _{IO} | Data Input/Output Capacitance: I/O0-I/O15 | 7 | pF |

Notes:

1. Tested initially and after any design or process changes that may affect these parameters.
2. Test conditions: T_A = 25°C, f = 1 MHz,

ELECTRICAL CHARACTERISTICS⁽¹⁾

(Recommended Operating Conditions unless otherwise noted.)

| Symbol | Parameter | Test Condition | Speed | Min. | Max. | Unit |
|------------------|---|--|------------|--------|------------|----------|
| I _{IL} | Input Leakage Current | Any input $0V \leq V_{IN} \leq V_{DD}$ Other inputs not under test = 0V | | -5 | 5 | μA |
| I _{IO} | Output Leakage Current | Output is disabled (Hi-Z) $0V \leq V_{OUT} \leq V_{DD}$ | | -5 | 5 | μA |
| V _{OH} | Output High Voltage Level | I _{OH} = -2.0 mA (3.3V) | | 2.4 | — | V |
| V _{OL} | Output Low Voltage Level | I _{OL} = 2.0 mA (3.3V) | | — | 0.4 | V |
| I _{CC1} | Standby Current: TTL | $\overline{RAS}, \overline{LCAS}, \overline{UCAS} \geq V_{IH}$ Commerical 3.3V Extended/Industrial 3.3V | | — | 1 2 | mA mA |
| I _{CC2} | Standby Current: CMOS | $\overline{RAS}, \overline{LCAS}, \overline{UCAS} \geq V_{DD} - 0.2V$ 3.3V | | — | 0.5 | mA |
| I _{CC3} | Operating Current: Random Read/Write ^(2,3,4) Average Power Supply Current | $\overline{RAS}, \overline{LCAS}, \overline{UCAS}$, Address Cycling, t _{RC} = t _{RC} (min.) | -50 -60 | — — | 160 145 | mA |
| I _{CC4} | Operating Current: Fast Page Mode ^(2,3,4) Average Power Supply Current | $\overline{RAS} = V_{IL}, \overline{LCAS}, \overline{UCAS}$, Cycling t _{PC} = t _{PC} (min.) | -50 -60 | — — | 90 80 | mA |
| I _{CC5} | Refresh Current: \overline{RAS} -Only ^(2,3) Average Power Supply Current | \overline{RAS} Cycling, $\overline{LCAS}, \overline{UCAS} \geq V_{IH}$ t _{RC} = t _{RC} (min.) | -50 -60 | — — | 160 145 | mA |
| I _{CC6} | Refresh Current: CBR ^(2,3,5) Average Power Supply Current | $\overline{RAS}, \overline{LCAS}, \overline{UCAS}$ Cycling t _{RC} = t _{RC} (min.) | -50 -60 | — — | 160 145 | mA |

Notes:

1. An initial pause of 200 μs is required after power-up followed by eight \overline{RAS} refresh cycles (\overline{RAS} -Only or CBR) before proper device operation is assured. The eight \overline{RAS} cycles wake-up should be repeated any time the t_{REF} refresh requirement is exceeded.
2. Dependent on cycle rates.
3. Specified values are obtained with minimum cycle time and the output open.
4. Column-address is changed once each Fast page cycle.
5. Enables on-chip refresh and address counters.

AC CHARACTERISTICS(1,2,3,4,5,6)

(Recommended Operating Conditions unless otherwise noted.)

| Symbol | Parameter | -50 | | -60 | | Units |
|-------------------|--|------|------|------|------|-------|
| | | Min. | Max. | Min. | Max. | |
| t _{RC} | Random READ or WRITE Cycle Time | 84 | — | 104 | — | ns |
| t _{RAC} | Access Time from $\overline{\text{RAS}}$ ^(6, 7) | — | 50 | — | 60 | ns |
| t _{CAC} | Access Time from $\overline{\text{CAS}}$ ^(6, 8, 15) | — | 13 | — | 15 | ns |
| t _{AA} | Access Time from Column-Address ⁽⁶⁾ | — | 25 | — | 30 | ns |
| t _{RAS} | $\overline{\text{RAS}}$ Pulse Width | 50 | 10K | 60 | 10K | ns |
| t _{RP} | $\overline{\text{RAS}}$ Precharge Time | 30 | — | 40 | — | ns |
| t _{CAS} | $\overline{\text{CAS}}$ Pulse Width ⁽²⁶⁾ | 8 | 10K | 10 | 10K | ns |
| t _{CP} | $\overline{\text{CAS}}$ Precharge Time ^(9, 25) | 9 | — | 9 | — | ns |
| t _{CSH} | $\overline{\text{CAS}}$ Hold Time ⁽²¹⁾ | 38 | — | 40 | — | ns |
| t _{RCD} | $\overline{\text{RAS}}$ to $\overline{\text{CAS}}$ Delay Time ^(10, 20) | 12 | 37 | 14 | 45 | ns |
| t _{ASR} | Row-Address Setup Time | 0 | — | 0 | — | ns |
| t _{RAH} | Row-Address Hold Time | 8 | — | 10 | — | ns |
| t _{ASC} | Column-Address Setup Time ⁽²⁰⁾ | 0 | — | 0 | — | ns |
| t _{CAH} | Column-Address Hold Time ⁽²⁰⁾ | 8 | — | 10 | — | ns |
| t _{AR} | Column-Address Hold Time (referenced to $\overline{\text{RAS}}$) | 30 | — | 40 | — | ns |
| t _{RAD} | $\overline{\text{RAS}}$ to Column-Address Delay Time ⁽¹¹⁾ | 10 | 25 | 12 | 30 | ns |
| t _{RAL} | Column-Address to $\overline{\text{RAS}}$ Lead Time | 25 | — | 30 | — | ns |
| t _{RPC} | $\overline{\text{RAS}}$ to $\overline{\text{CAS}}$ Precharge Time | 5 | — | 5 | — | ns |
| t _{RSH} | $\overline{\text{RAS}}$ Hold Time ⁽²⁷⁾ | 8 | — | 10 | — | ns |
| t _{RHCP} | $\overline{\text{RAS}}$ Hold Time from $\overline{\text{CAS}}$ Precharge | 37 | — | 37 | — | ns |
| t _{CLZ} | $\overline{\text{CAS}}$ to Output in Low-Z ^(15, 29) | 0 | — | 0 | — | ns |
| t _{CRP} | $\overline{\text{CAS}}$ to $\overline{\text{RAS}}$ Precharge Time ⁽²¹⁾ | 5 | — | 5 | — | ns |
| t _{OD} | Output Disable Time ^(19, 28, 29) | 3 | 15 | 3 | 15 | ns |
| t _{OE} | Output Enable Time ^(15, 16) | — | 13 | — | 15 | ns |
| t _{OED} | Output Enable Data Delay (Write) | 20 | — | 20 | — | ns |
| t _{OEHC} | $\overline{\text{OE}}$ HIGH Hold Time from $\overline{\text{CAS}}$ HIGH | 5 | — | 5 | — | ns |
| t _{OEPL} | $\overline{\text{OE}}$ HIGH Pulse Width | 10 | — | 10 | — | ns |
| t _{OES} | $\overline{\text{OE}}$ LOW to $\overline{\text{CAS}}$ HIGH Setup Time | 5 | — | 5 | — | ns |
| t _{RCS} | Read Command Setup Time ^(17, 20) | 0 | — | 0 | — | ns |
| t _{RRH} | Read Command Hold Time (referenced to $\overline{\text{RAS}}$) ⁽¹²⁾ | 0 | — | 0 | — | ns |
| t _{RCH} | Read Command Hold Time (referenced to $\overline{\text{CAS}}$) ^(12, 17, 21) | 0 | — | 0 | — | ns |
| t _{WCH} | Write Command Hold Time ^(17, 27) | 8 | — | 10 | — | ns |

AC CHARACTERISTICS (Continued)^(1,2,3,4,5,6)

(Recommended Operating Conditions unless otherwise noted.)

| Symbol | Parameter | -50 | | -60 | | Units |
|--------|---|------|------|------|------|-------|
| | | Min. | Max. | Min. | Max. | |
| tWCR | Write Command Hold Time (referenced to $\overline{\text{RAS}}$) ⁽¹⁷⁾ | 40 | — | 50 | — | ns |
| tWP | Write Command Pulse Width ⁽¹⁷⁾ | 8 | — | 10 | — | ns |
| tWPZ | $\overline{\text{WE}}$ Pulse Widths to Disable Outputs | 10 | — | 10 | — | ns |
| tRWL | Write Command to $\overline{\text{RAS}}$ Lead Time ⁽¹⁷⁾ | 13 | — | 15 | — | ns |
| tcWL | Write Command to $\overline{\text{CAS}}$ Lead Time ^(17, 21) | 8 | — | 10 | — | ns |
| twCS | Write Command Setup Time ^(14, 17, 20) | 0 | — | 0 | — | ns |
| tDHR | Data-in Hold Time (referenced to $\overline{\text{RAS}}$) | 39 | — | 39 | — | ns |
| tACH | Column-Address Setup Time to $\overline{\text{CAS}}$ Precharge during WRITE Cycle | 15 | — | 15 | — | ns |
| toEH | $\overline{\text{OE}}$ Hold Time from $\overline{\text{WE}}$ during READ-MODIFY-WRITE cycle ⁽¹⁸⁾ | 8 | — | 10 | — | ns |
| tdS | Data-In Setup Time ^(15, 22) | 0 | — | 0 | — | ns |
| tdH | Data-In Hold Time ^(15, 22) | 8 | — | 10 | — | ns |
| trWC | READ-MODIFY-WRITE Cycle Time | 108 | — | 133 | — | ns |
| trWD | $\overline{\text{RAS}}$ to $\overline{\text{WE}}$ Delay Time during READ-MODIFY-WRITE Cycle ⁽¹⁴⁾ | 64 | — | 77 | — | ns |
| tcWD | $\overline{\text{CAS}}$ to $\overline{\text{WE}}$ Delay Time ^(14, 20) | 26 | — | 32 | — | ns |
| tAWD | Column-Address to $\overline{\text{WE}}$ Delay Time ⁽¹⁴⁾ | 39 | — | 47 | — | ns |
| tpC | Fast Page Mode READ or WRITE Cycle Time ⁽²⁴⁾ | 20 | — | 25 | — | ns |
| trASP | $\overline{\text{RAS}}$ Pulse Width | 50 | 100K | 60 | 100K | ns |
| tCPA | Access Time from $\overline{\text{CAS}}$ Precharge ⁽¹⁵⁾ | — | 30 | — | 35 | ns |
| tPRWC | READ-WRITE Cycle Time ⁽²⁴⁾ | 56 | — | 68 | — | ns |
| tCOH | Data Output Hold after $\overline{\text{CAS}}$ LOW | 5 | — | 5 | — | ns |
| toFF | Output Buffer Turn-Off Delay from $\overline{\text{CAS}}$ or $\overline{\text{RAS}}$ ^(13,15,19, 29) | 1.6 | 12 | 1.6 | 15 | ns |
| tWHZ | Output Disable Delay from $\overline{\text{WE}}$ | 3 | 10 | 3 | 10 | ns |
| tCLCH | Last $\overline{\text{CAS}}$ going LOW to First $\overline{\text{CAS}}$ returning HIGH ⁽²³⁾ | 10 | — | 10 | — | ns |
| tCSR | $\overline{\text{CAS}}$ Setup Time (CBR REFRESH) ^(30, 20) | 5 | — | 5 | — | ns |
| tCHR | $\overline{\text{CAS}}$ Hold Time (CBR REFRESH) ^(30, 21) | 8 | — | 10 | — | ns |
| toRD | $\overline{\text{OE}}$ Setup Time prior to $\overline{\text{RAS}}$ during HIDDEN REFRESH Cycle | 0 | — | 0 | — | ns |
| tREF | Auto Refresh Period (1,024 Cycles) | — | 16 | — | 16 | ms |
| tr | Transition Time (Rise or Fall) ^(2, 3) | 1 | 50 | 1 | 50 | ns |

AC TEST CONDITIONS

Output load: One TTL Load and 50 pF ($V_{DD} = 3.3V \pm 10\%$)

Input timing reference levels: $V_{IH} = 2.0V$, $V_{IL} = 0.8V$ ($V_{DD} = 3.3V \pm 10\%$)

Output timing reference levels: $V_{OH} = 2.0V$, $V_{OL} = 0.8V$ ($3.3V \pm 10\%$)

Notes:

1. An initial pause of 200 μs is required after power-up followed by eight \overline{RAS} refresh cycle (\overline{RAS} -Only or CBR) before proper device operation is assured. The eight \overline{RAS} cycles wake-up should be repeated any time the t_{REF} refresh requirement is exceeded.
2. V_{IH} (MIN) and V_{IL} (MAX) are reference levels for measuring timing of input signals. Transition times, are measured between V_{IH} and V_{IL} (or between V_{IL} and V_{IH}) and assume to be 1 ns for all inputs.
3. In addition to meeting the transition rate specification, all input signals must transit between V_{IH} and V_{IL} (or between V_{IL} and V_{IH}) in a monotonic manner.
4. If \overline{CAS} and $\overline{RAS} = V_{IH}$, data output is High-Z.
5. If $\overline{CAS} = V_{IL}$, data output may contain data from the last valid READ cycle.
6. Measured with a load equivalent to one TTL gate and 50 pF.
7. Assumes that $t_{RCD} \leq t_{RCD} (MAX)$. If t_{RCD} is greater than the maximum recommended value shown in this table, t_{RAC} will increase by the amount that t_{RCD} exceeds the value shown.
8. Assumes that $t_{RCD} \geq t_{RCD} (MAX)$.
9. If \overline{CAS} is LOW at the falling edge of \overline{RAS} , data out will be maintained from the previous cycle. To initiate a new cycle and clear the data output buffer, \overline{CAS} and \overline{RAS} must be pulsed for t_{CP} .
10. Operation with the $t_{RCD} (MAX)$ limit ensures that $t_{RAC} (MAX)$ can be met. $t_{RCD} (MAX)$ is specified as a reference point only; if t_{RCD} is greater than the specified $t_{RCD} (MAX)$ limit, access time is controlled exclusively by t_{CAC} .
11. Operation within the $t_{RAD} (MAX)$ limit ensures that $t_{RCD} (MAX)$ can be met. $t_{RAD} (MAX)$ is specified as a reference point only; if t_{RAD} is greater than the specified $t_{RAD} (MAX)$ limit, access time is controlled exclusively by t_{AA} .
12. Either t_{RCH} or t_{RRH} must be satisfied for a READ cycle.
13. $t_{OFF} (MAX)$ defines the time at which the output achieves the open circuit condition; it is not a reference to V_{OH} or V_{OL} .
14. t_{WCS} , t_{RWD} , t_{AWD} and t_{CWD} are restrictive operating parameters in LATE WRITE and READ-MODIFY-WRITE cycle only. If $t_{WCS} \geq t_{WCS} (MIN)$, the cycle is an EARLY WRITE cycle and the data output will remain open circuit throughout the entire cycle. If $t_{RWD} \geq t_{RWD} (MIN)$, $t_{AWD} \geq t_{AWD} (MIN)$ and $t_{CWD} \geq t_{CWD} (MIN)$, the cycle is a READ-WRITE cycle and the data output will contain data read from the selected cell. If neither of the above conditions is met, the state of I/O (at access time and until \overline{CAS} and \overline{RAS} or \overline{OE} go back to V_{IH}) is indeterminate. \overline{OE} held HIGH and \overline{WE} taken LOW after \overline{CAS} goes LOW result in a LATE WRITE (\overline{OE} -controlled) cycle.
15. Output parameter (I/O) is referenced to corresponding \overline{CAS} input, I/O0-I/O7 by \overline{LCAS} and I/O8-I/O15 by \overline{UCAS} .
16. During a READ cycle, if \overline{OE} is LOW then taken HIGH before \overline{CAS} goes HIGH, I/O goes open. If \overline{OE} is tied permanently LOW, a LATE WRITE or READ-MODIFY-WRITE is not possible.
17. Write command is defined as \overline{WE} going low.
18. LATE WRITE and READ-MODIFY-WRITE cycles must have both t_{OD} and t_{OEH} met (\overline{OE} HIGH during WRITE cycle) in order to ensure that the output buffers will be open during the WRITE cycle. The I/Os will provide the previously written data if \overline{CAS} remains LOW and \overline{OE} is taken back to LOW after t_{OEH} is met.
19. The I/Os are in open during READ cycles once t_{OD} or t_{OFF} occur.
20. The first $\chi\overline{CAS}$ edge to transition LOW.
21. The last $\chi\overline{CAS}$ edge to transition HIGH.
22. These parameters are referenced to \overline{CAS} leading edge in EARLY WRITE cycles and \overline{WE} leading edge in LATE WRITE or READ-MODIFY-WRITE cycles.
23. Last falling $\chi\overline{CAS}$ edge to first rising $\chi\overline{CAS}$ edge.
24. Last rising $\chi\overline{CAS}$ edge to next cycle's last rising $\chi\overline{CAS}$ edge.
25. Last rising $\chi\overline{CAS}$ edge to first falling $\chi\overline{CAS}$ edge.
26. Each $\chi\overline{CAS}$ must meet minimum pulse width.
27. Last $\chi\overline{CAS}$ to go LOW.
28. I/Os controlled, regardless \overline{UCAS} and \overline{LCAS} .
29. The 3 ns minimum is a parameter guaranteed by design.
30. Enables on-chip refresh and address counters.

FAST-PAGE-MODE READ CYCLE

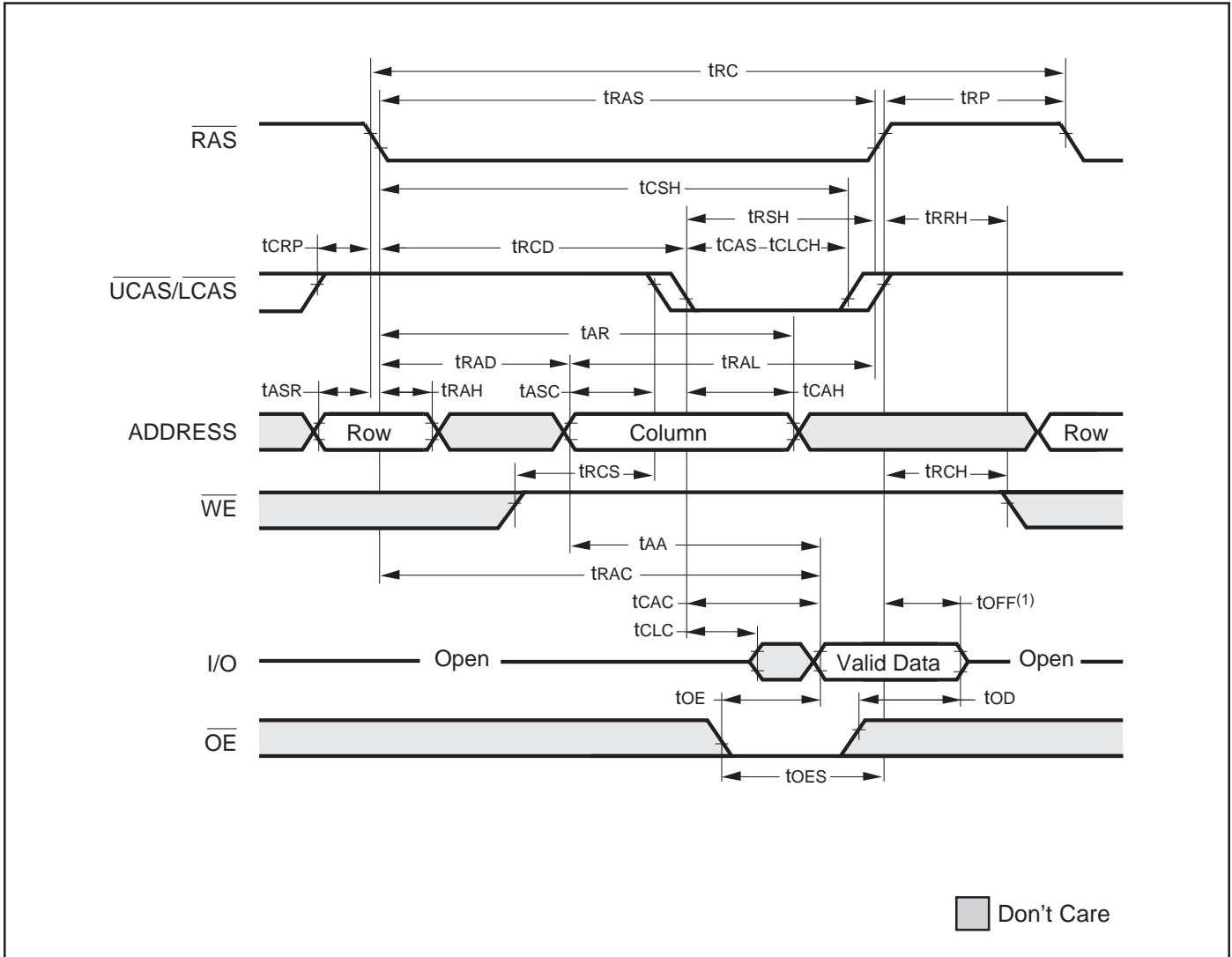

Note:
 1. t_{OFF} is referenced from rising edge of \overline{RAS} or \overline{CAS} , whichever occurs last.

FAST-PAGE-MODE EARLY WRITE CYCLE (\overline{OE} = DON'T CARE)

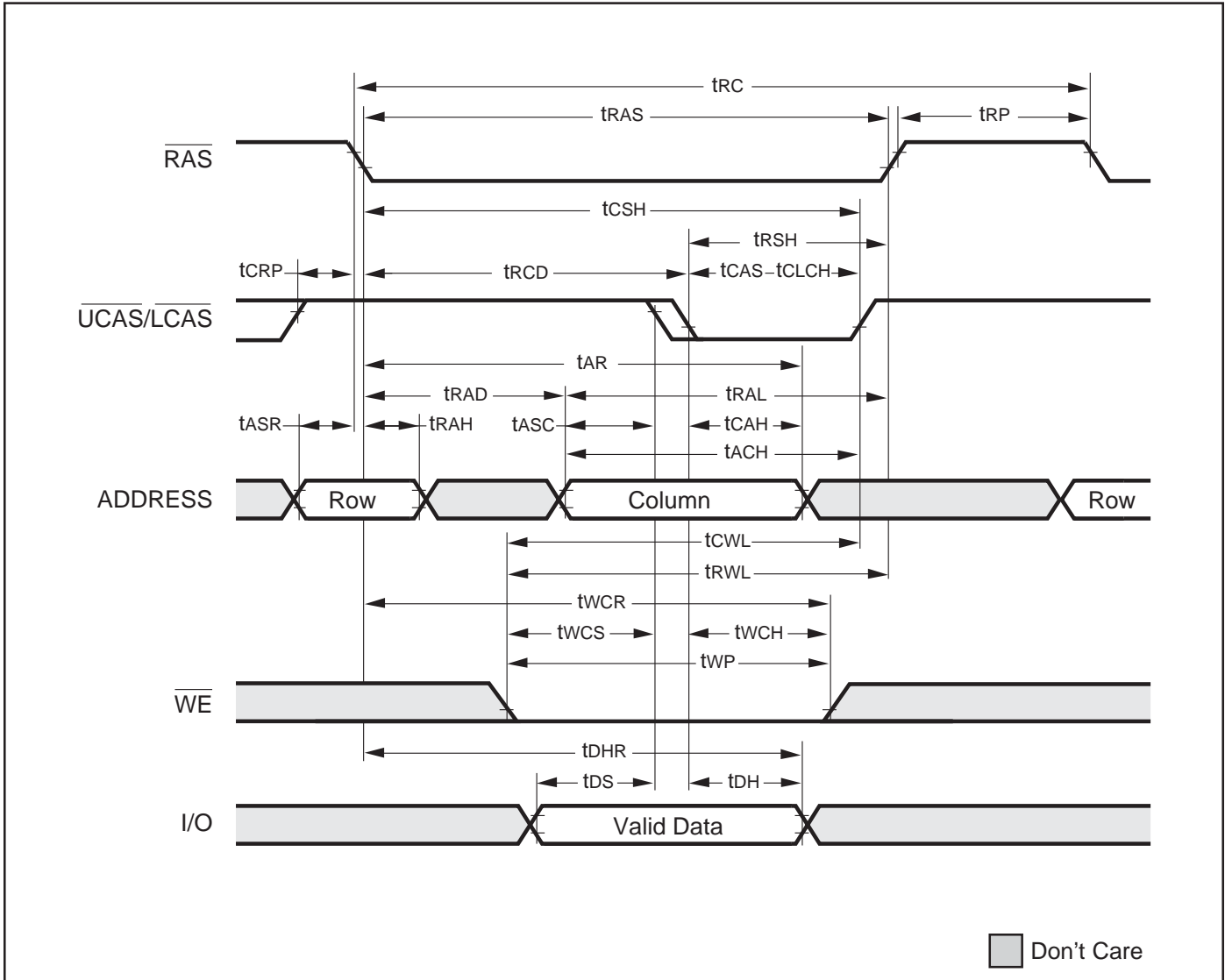

FAST-PAGE-MODE READ WRITE CYCLE (LATE WRITE and READ-MODIFY-WRITE Cycles)

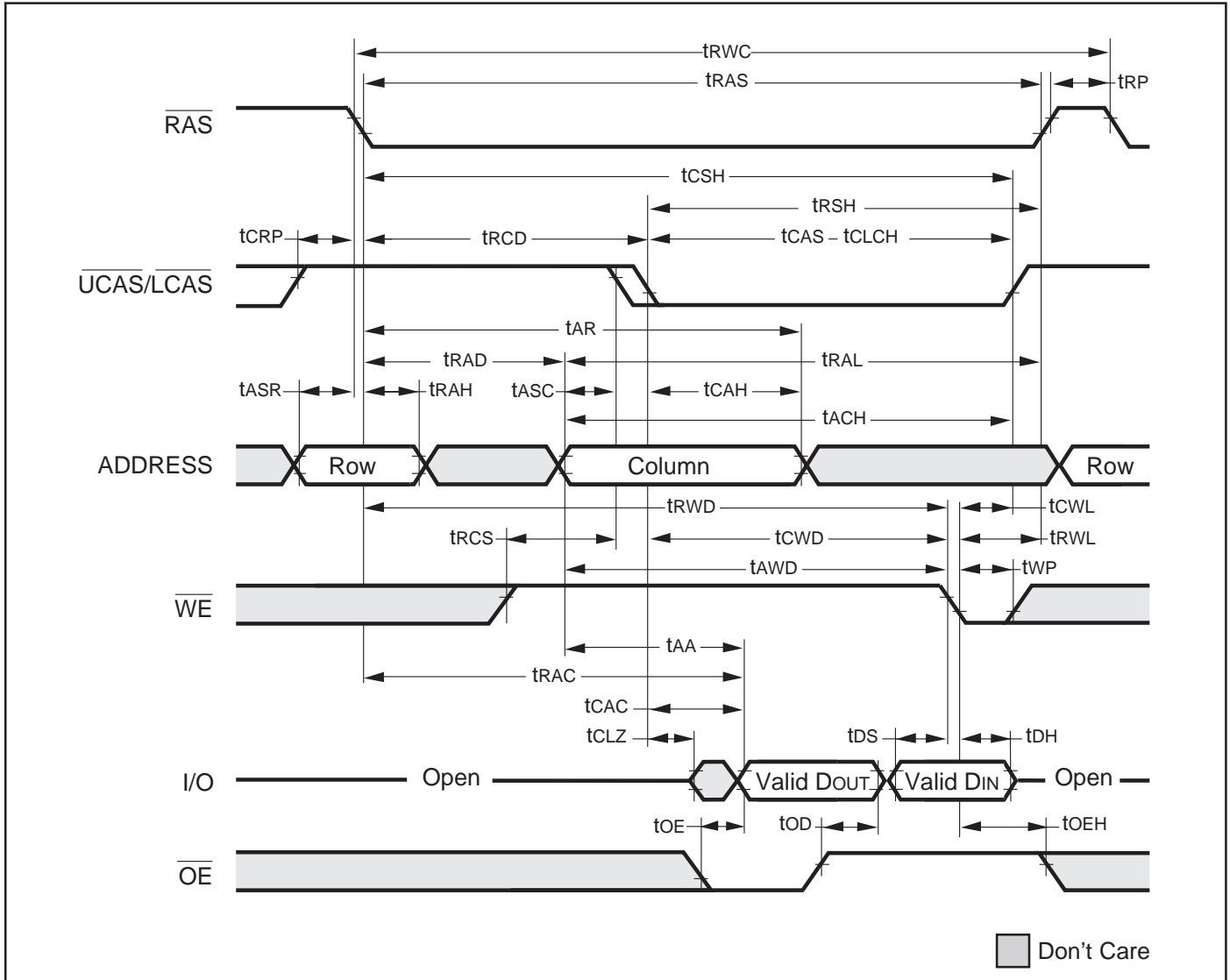

FAST PAGE MODE EARLY WRITE CYCLE

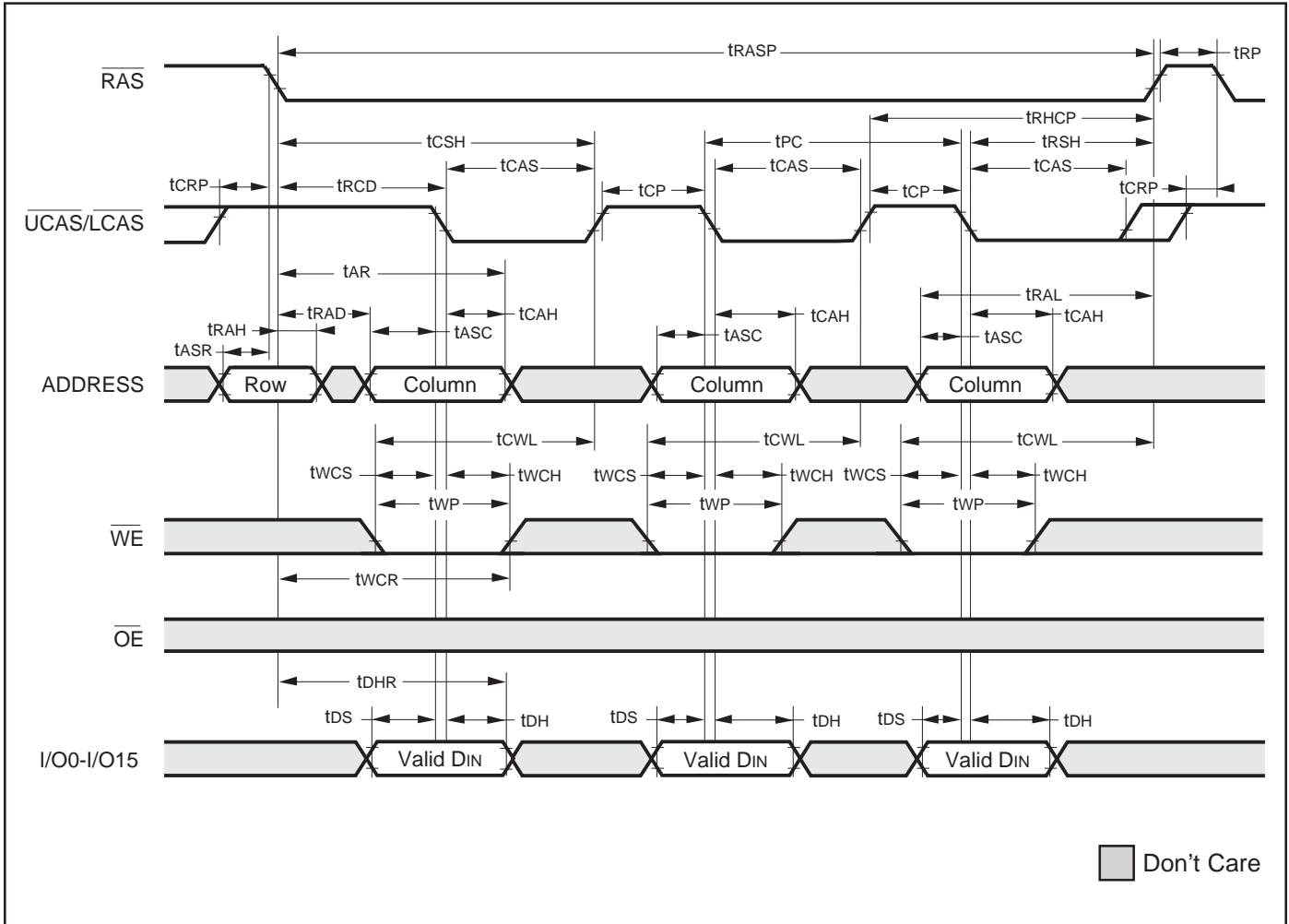

AC WAVEFORMS

READ CYCLE (With \overline{WE} -Controlled Disable)

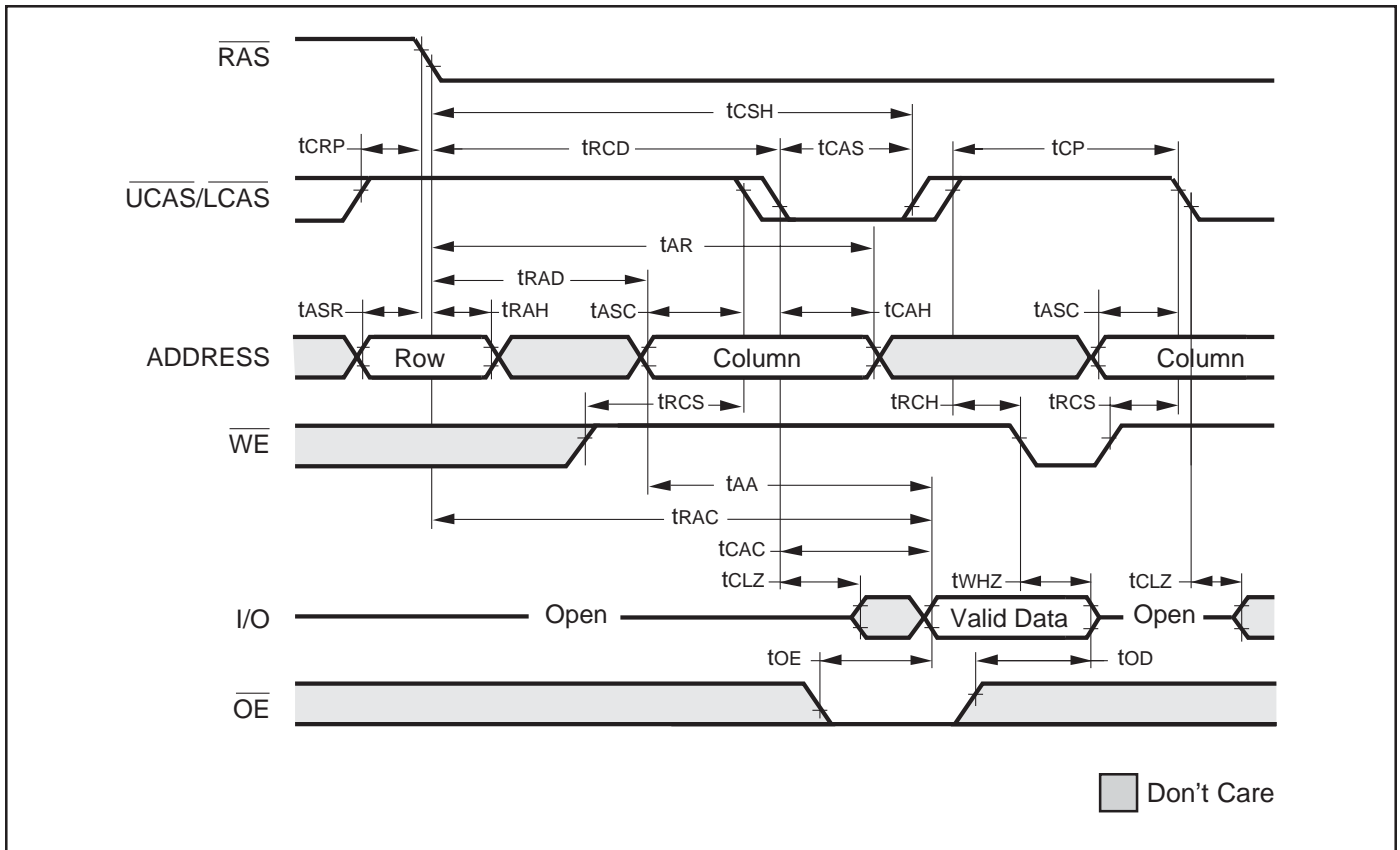

\overline{RAS} -ONLY REFRESH CYCLE (\overline{OE} , \overline{WE} = DON'T CARE)

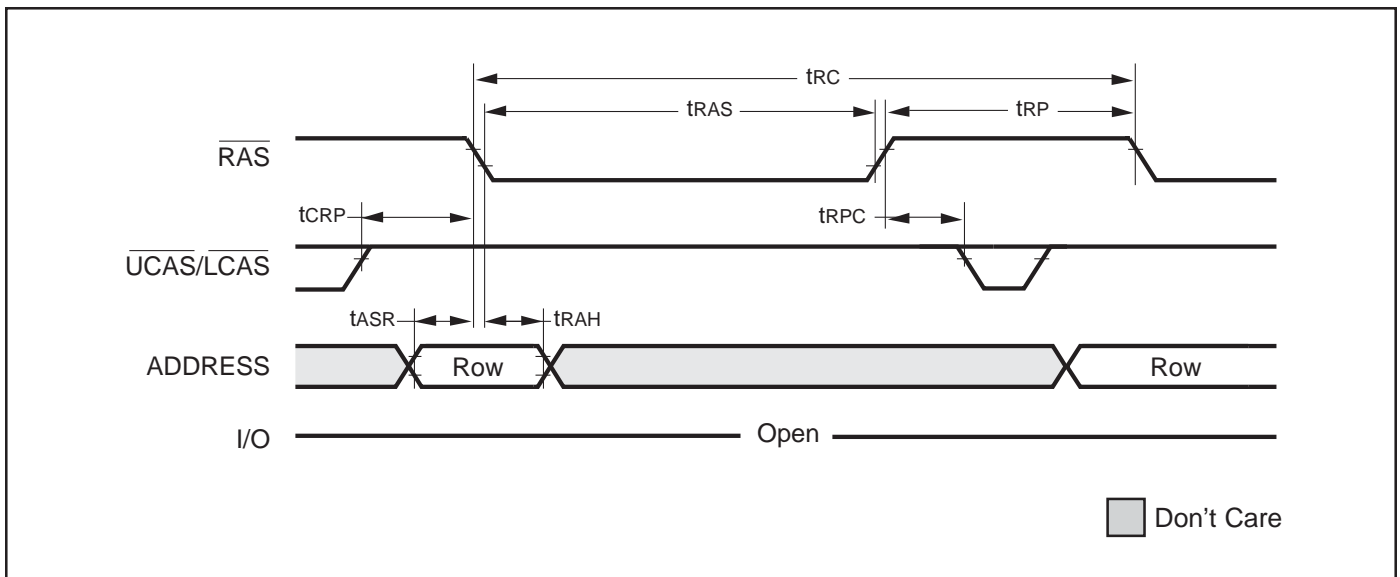

$\overline{\text{CBR}}$ REFRESH CYCLE (Addresses; $\overline{\text{WE}}$, $\overline{\text{OE}}$ = DON'T CARE)

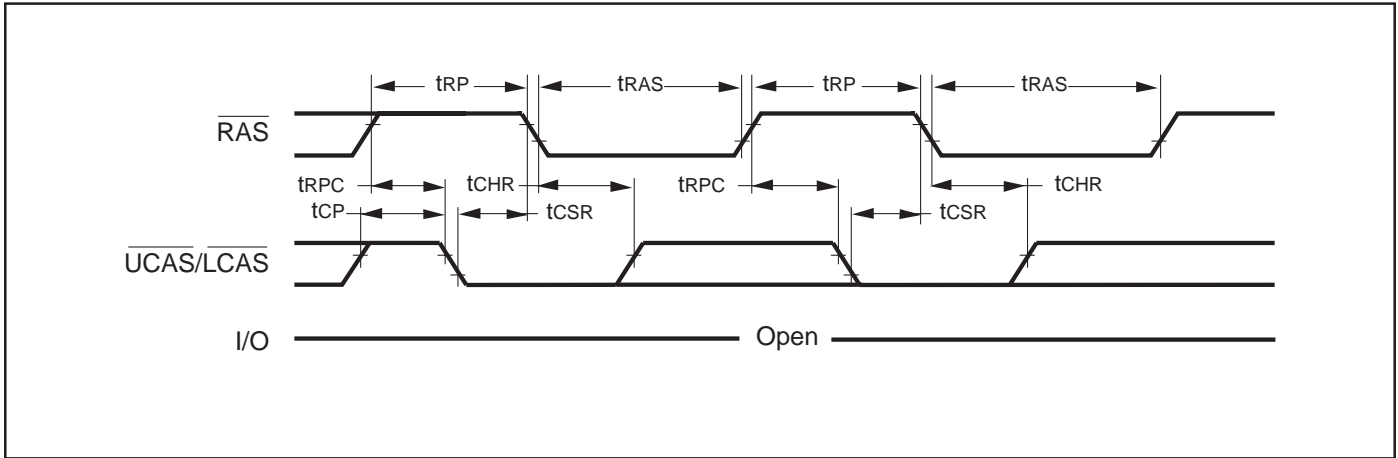

HIDDEN REFRESH CYCLE⁽¹⁾ ($\overline{\text{WE}}$ = HIGH; $\overline{\text{OE}}$ = LOW)

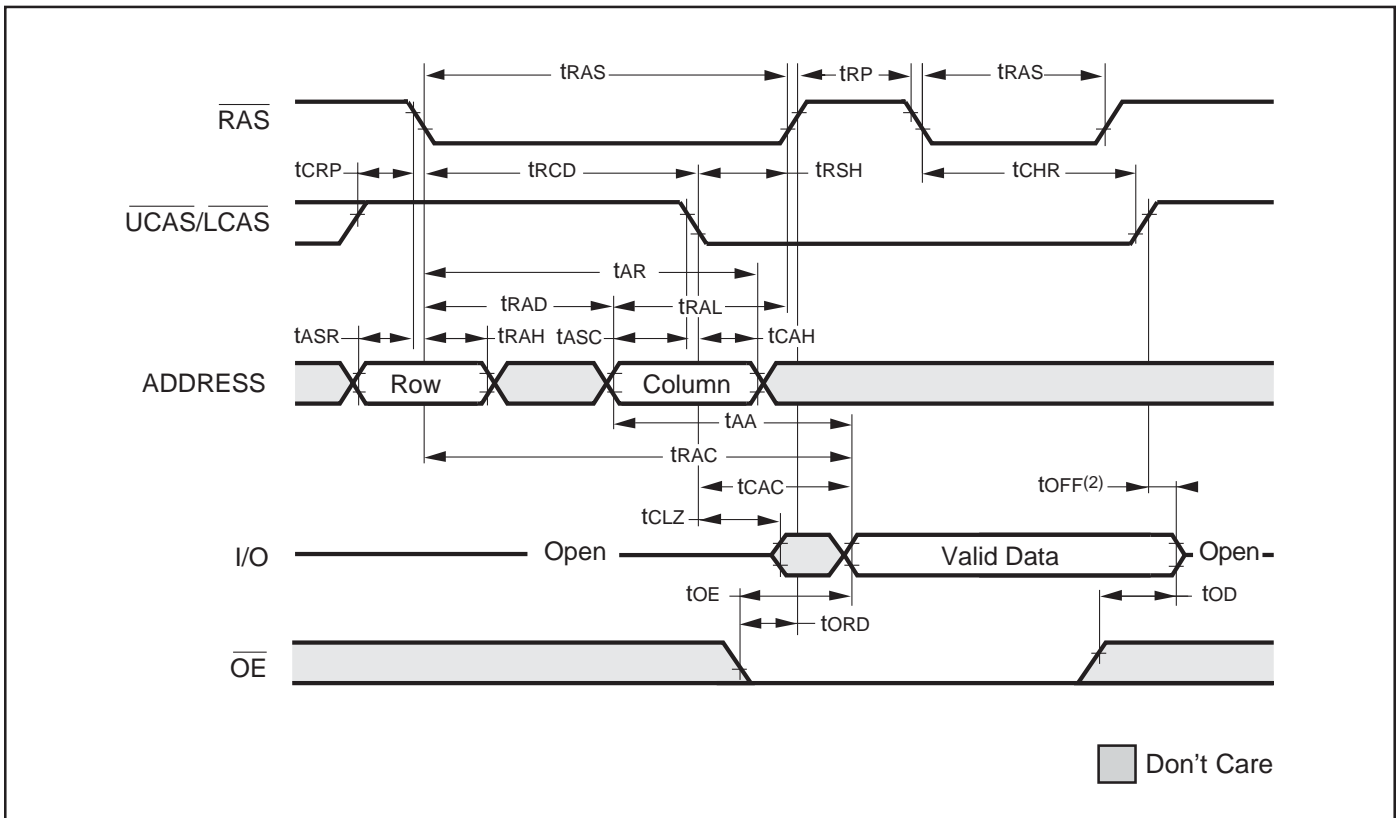

Notes:

1. A Hidden Refresh may also be performed after a Write Cycle. In this case, $\overline{\text{WE}}$ = LOW and $\overline{\text{OE}}$ = HIGH.
2. t_{OFF} is referenced from rising edge of $\overline{\text{RAS}}$ or $\overline{\text{CAS}}$, whichever occurs last.

ORDERING INFORMATION : 3.3V**Commercial Range: 0°C to +70°C**

| Speed (ns) | Order Part No. | Package |
|------------|-------------------|-----------------------------------|
| 50 | IS41LV16105B-50K | 400-mil SOJ |
| | IS41LV16105B-50KL | 400-mil SOJ, Lead-free |
| | IS41LV16105B-50T | 400-mil TSOP (Type II) |
| | IS41LV16105B-50TL | 400-mil TSOP (Type II), Lead-free |
| 60 | IS41LV16105B-60K | 400-mil SOJ |
| | IS41LV16105B-60KL | 400-mil SOJ, Lead-free |
| | IS41LV16105B-60T | 400-mil TSOP (Type II) |
| | IS41LV16105B-60TL | 400-mil TSOP (Type II), Lead-free |

Extended Range: -30°C to +85°C

| Speed (ns) | Order Part No. | Package |
|------------|--------------------|-----------------------------------|
| 50 | IS41LV16105B-50KE | 400-mil SOJ |
| | IS41LV16105B-50KLE | 400-mil SOJ, Lead-free |
| | IS41LV16105B-50TE | 400-mil TSOP (Type II) |
| | IS41LV16105B-50TLE | 400-mil TSOP (Type II), Lead-free |
| 60 | IS41LV16105B-60KE | 400-mil SOJ |
| | IS41LV16105B-60KLE | 400-mil SOJ, Lead-free |
| | IS41LV16105B-60TE | 400-mil TSOP (Type II) |
| | IS41LV16105B-60TLE | 400-mil TSOP (Type II), Lead-free |

Industrial Range: -40°C to +85°C

| Speed (ns) | Order Part No. | Package |
|------------|--------------------|-----------------------------------|
| 50 | IS41LV16105B-50KI | 400-mil SOJ |
| | IS41LV16105B-50KLI | 400-mil SOJ, Lead-free |
| | IS41LV16105B-50TI | 400-mil TSOP (Type II) |
| | IS41LV16105B-50TLI | 400-mil TSOP (Type II), Lead-free |
| 60 | IS41LV16105B-60KI | 400-mil SOJ |
| | IS41LV16105B-60KLI | 400-mil SOJ, Lead-free |
| | IS41LV16105B-60TI | 400-mil TSOP (Type II) |
| | IS41LV16105B-60TLI | 400-mil TSOP (Type II), Lead-free |

PACKAGING INFORMATION

400-mil Plastic SOJ

Package Code: K

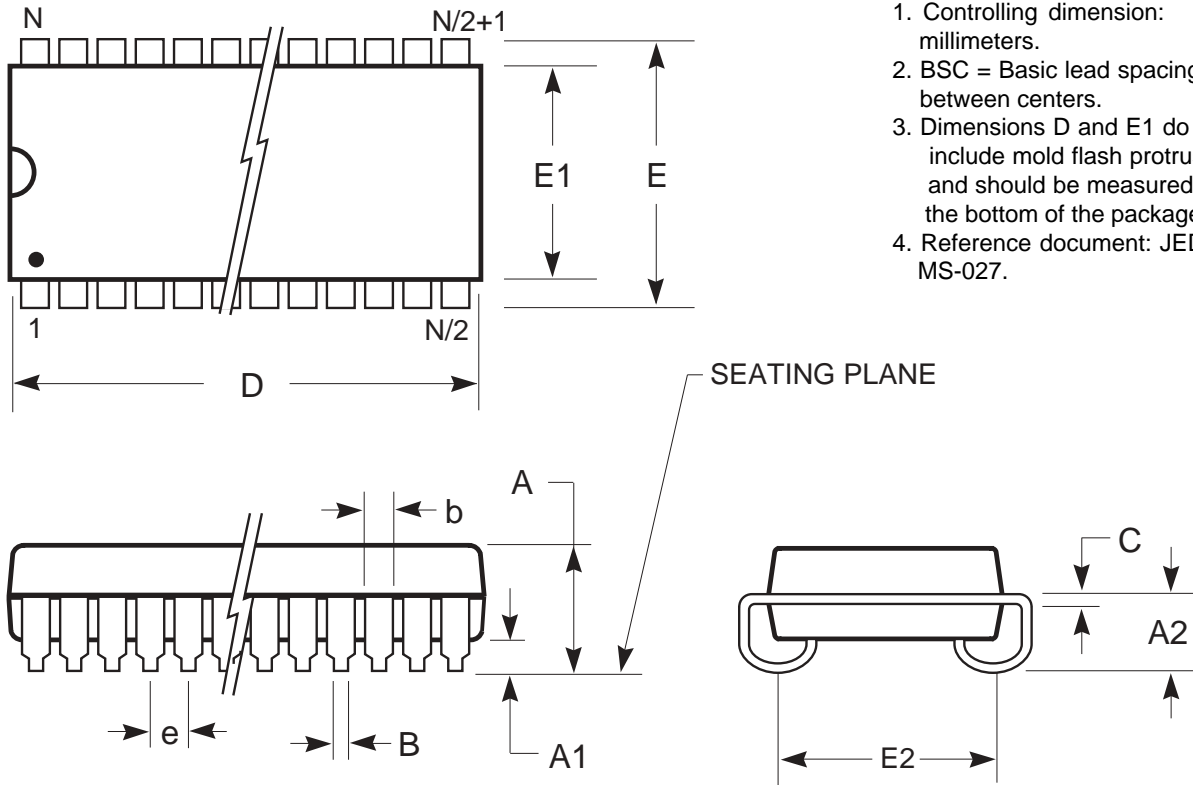

Notes:

1. Controlling dimension: millimeters.
2. BSC = Basic lead spacing between centers.
3. Dimensions D and E1 do not include mold flash protrusions and should be measured from the bottom of the package.
4. Reference document: JEDEC MS-027.

| Symbol | Millimeters | | Inches | | Millimeters | | Inches | | Millimeters | | Inches | |
|---------------|-------------|-------|-----------|-------|-------------|-------|-----------|-------|-------------|-------|-----------|-------|
| | Min | Max | Min | Max | Min | Max | Min | Max | Min | Max | Min | Max |
| No. Leads (N) | 28 | | | | 32 | | | | 36 | | | |
| A | 3.25 | 3.75 | 0.128 | 0.148 | 3.25 | 3.75 | 0.128 | 0.148 | 3.25 | 3.75 | 0.128 | 0.148 |
| A1 | 0.64 | — | 0.025 | — | 0.64 | — | 0.025 | — | 0.64 | — | 0.025 | — |
| A2 | 2.08 | — | 0.082 | — | 2.08 | — | 0.082 | — | 2.08 | — | 0.082 | — |
| B | 0.38 | 0.51 | 0.015 | 0.020 | 0.38 | 0.51 | 0.015 | 0.020 | 0.38 | 0.51 | 0.015 | 0.020 |
| b | 0.66 | 0.81 | 0.026 | 0.032 | 0.66 | 0.81 | 0.026 | 0.032 | 0.66 | 0.81 | 0.026 | 0.032 |
| C | 0.18 | 0.33 | 0.007 | 0.013 | 0.18 | 0.33 | 0.007 | 0.013 | 0.18 | 0.33 | 0.007 | 0.013 |
| D | 18.29 | 18.54 | 0.720 | 0.730 | 20.82 | 21.08 | 0.820 | 0.830 | 23.37 | 23.62 | 0.920 | 0.930 |
| E | 11.05 | 11.30 | 0.435 | 0.445 | 11.05 | 11.30 | 0.435 | 0.445 | 11.05 | 11.30 | 0.435 | 0.445 |
| E1 | 10.03 | 10.29 | 0.395 | 0.405 | 10.03 | 10.29 | 0.395 | 0.405 | 10.03 | 10.29 | 0.395 | 0.405 |
| E2 | 9.40 BSC | | 0.370 BSC | | 9.40 BSC | | 0.370 BSC | | 9.40 BSC | | 0.370 BSC | |
| e | 1.27 BSC | | 0.050 BSC | | 1.27 BSC | | 0.050 BSC | | 1.27 BSC | | 0.050 BSC | |

Copyright © 2003 Integrated Silicon Solution, Inc. All rights reserved. ISSI reserves the right to make changes to this specification and its products at any time without notice. ISSI assumes no liability arising out of the application or use of any information, products or services described herein. Customers are advised to obtain the latest version of this device specification before relying on any published information and before placing orders for products.

| Symbol | Millimeters | | Inches | | Millimeters | | Inches | | Millimeters | | Inches | |
|---------------|-------------|-------|-----------|-------|-------------|-------|-----------|-------|-------------|-------|-----------|-------|
| | Min | Max | Min | Max | Min | Max | Min | Max | Min | Max | Min | Max |
| No. Leads (N) | 40 | | | | 42 | | | | 44 | | | |
| A | 3.25 | 3.75 | 0.128 | 0.148 | 3.25 | 3.75 | 0.128 | 0.148 | 3.25 | 3.75 | 0.128 | 0.148 |
| A1 | 0.64 | — | 0.025 | — | 0.64 | — | 0.025 | — | 0.64 | — | 0.025 | — |
| A2 | 2.08 | — | 0.082 | — | 2.08 | — | 0.082 | — | 2.08 | — | 0.082 | — |
| B | 0.38 | 0.51 | 0.015 | 0.020 | 0.38 | 0.51 | 0.015 | 0.020 | 0.38 | 0.51 | 0.015 | 0.020 |
| b | 0.66 | 0.81 | 0.026 | 0.032 | 0.66 | 0.81 | 0.026 | 0.032 | 0.66 | 0.81 | 0.026 | 0.032 |
| C | 0.18 | 0.33 | 0.007 | 0.013 | 0.18 | 0.33 | 0.007 | 0.013 | 0.18 | 0.33 | 0.007 | 0.013 |
| D | 25.91 | 26.16 | 1.020 | 1.030 | 27.18 | 27.43 | 1.070 | 1.080 | 28.45 | 28.70 | 1.120 | 1.130 |
| E | 11.05 | 11.30 | 0.435 | 0.445 | 11.05 | 11.30 | 0.435 | 0.445 | 11.05 | 11.30 | 0.435 | 0.445 |
| E1 | 10.03 | 10.29 | 0.395 | 0.405 | 10.03 | 10.29 | 0.395 | 0.405 | 10.03 | 10.29 | 0.395 | 0.405 |
| E2 | 9.40 BSC | | 0.370 BSC | | 9.40 BSC | | 0.370 BSC | | 9.40 BSC | | 0.370 BSC | |
| e | 1.27 BSC | | 0.050 BSC | | 1.27 BSC | | 0.050 BSC | | 1.27 BSC | | 0.050 BSC | |

Copyright © 2003 Integrated Silicon Solution, Inc. All rights reserved. ISSI reserves the right to make changes to this specification and its products at any time without notice. ISSI assumes no liability arising out of the application or use of any information, products or services described herein. Customers are advised to obtain the latest version of this device specification before relying on any published information and before placing orders for products.

PACKAGING INFORMATION



Plastic TSOP Package Code: T (Type II)

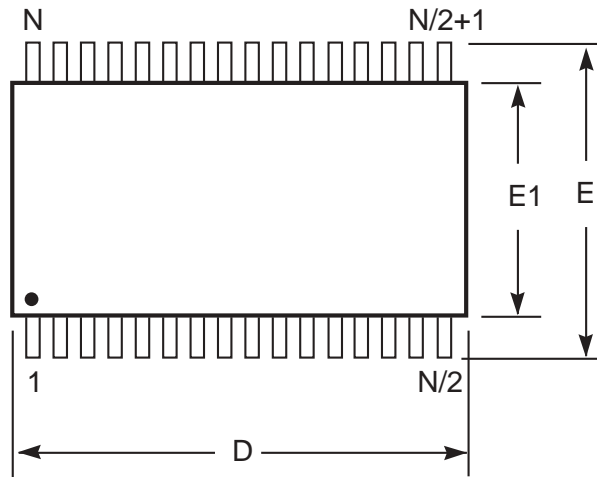

Notes:

1. Controlling dimension: millimeters, unless otherwise specified.
2. BSC = Basic lead spacing between centers.
3. Dimensions D and E1 do not include mold flash protrusions and should be measured from the bottom of the package.
4. Formed leads shall be planar with respect to one another within 0.004 inches at the seating plane.

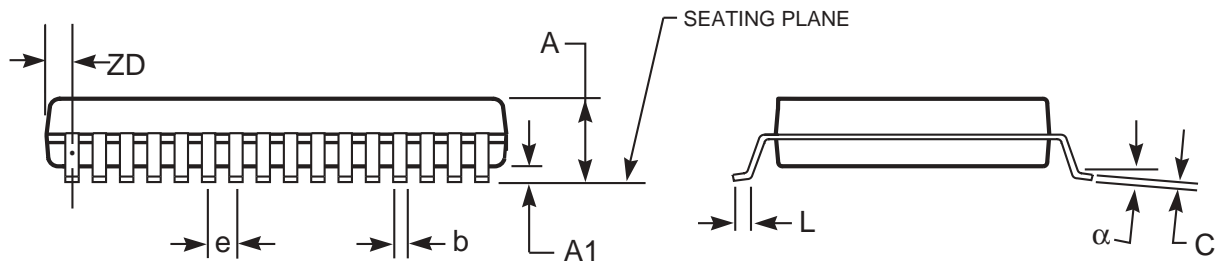

Plastic TSOP (T - Type II)

| Symbol | Millimeters | | Inches | | Millimeters | | Inches | | Millimeters | | Inches | |
|---------------|-------------|-------|-----------|-------|-------------|-------|-----------|-------|-------------|-------|-----------|-------|
| | Min | Max | Min | Max | Min | Max | Min | Max | Min | Max | Min | Max |
| Ref. Std. | | | | | | | | | | | | |
| No. Leads (N) | 32 | | | | 44 | | | | 50 | | | |
| A | — | 1.20 | — | 0.047 | — | 1.20 | — | 0.047 | — | 1.20 | — | 0.047 |
| A1 | 0.05 | 0.15 | 0.002 | 0.006 | 0.05 | 0.15 | 0.002 | 0.006 | 0.05 | 0.15 | 0.002 | 0.006 |
| b | 0.30 | 0.52 | 0.012 | 0.020 | 0.30 | 0.45 | 0.012 | 0.018 | 0.30 | 0.45 | 0.012 | 0.018 |
| C | 0.12 | 0.21 | 0.005 | 0.008 | 0.12 | 0.21 | 0.005 | 0.008 | 0.12 | 0.21 | 0.005 | 0.008 |
| D | 20.82 | 21.08 | 0.820 | 0.830 | 18.31 | 18.52 | 0.721 | 0.729 | 20.82 | 21.08 | 0.820 | 0.830 |
| E1 | 10.03 | 10.29 | 0.391 | 0.400 | 10.03 | 10.29 | 0.395 | 0.405 | 10.03 | 10.29 | 0.395 | 0.405 |
| E | 11.56 | 11.96 | 0.451 | 0.466 | 11.56 | 11.96 | 0.455 | 0.471 | 11.56 | 11.96 | 0.455 | 0.471 |
| e | 1.27 BSC | | 0.050 BSC | | 0.80 BSC | | 0.032 BSC | | 0.80 BSC | | 0.031 BSC | |
| L | 0.40 | 0.60 | 0.016 | 0.024 | 0.41 | 0.60 | 0.016 | 0.024 | 0.40 | 0.60 | 0.016 | 0.024 |
| ZD | 0.95 REF | | 0.037 REF | | 0.81 REF | | 0.032 REF | | 0.88 REF | | 0.035 REF | |
| α | 0° | 5° | 0° | 5° | 0° | 5° | 0° | 5° | 0° | 5° | 0° | 5° |

Copyright © 2003 Integrated Silicon Solution, Inc. All rights reserved. ISSI reserves the right to make changes to this specification and its products at any time without notice. ISSI assumes no liability arising out of the application or use of any information, products or services described herein. Customers are advised to obtain the latest version of this device specification before relying on any published information and before placing orders for products.

Integrated Silicon Solution, Inc. — www.issi.com — 1-800-379-4774

Rev. F
06/18/03