

50V CERAMIC DISC

89000 SERIES

The 89000 series is a range of insulated disc, monolithic fixed ceramic capacitors. They are most commonly used in consumer electronics and telecommunication equipment.

RATINGS

Capacitance Range: 1.0pf to 0.10 μ f (100,000pf)

Voltage: 50 Volts DC

Withstand Voltage: 150 Volts DC

PERFORMANCE SPECIFICATIONS

Operating Temperature Range:

-25°C to +85°C (-13°F to +185°F)

Tolerance Range:

8901D0-89010	±0.5pf
89012-89312	±10%
89315	±20%
89322-89410	+80%, -20%

Temperature Coefficient:

8901D0-89110	-	NPO (Stable)
89112-89310	-	YSP (\pm 10%)
89312-89315	-	Y5R (\pm 15%)
89322-89410	-	Y5V (+30% - 80%)

Insulation Resistance: 10,000M Ω Min,
but, 5,000M Ω Min for capacitance over
0.020 μ f

ORDERING INFORMATION

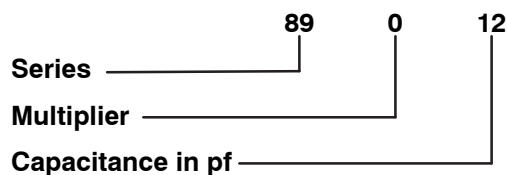

Example: 8901D5 = 1.5pf
89012 = 12pf
89112 = 120pf

MARKING EXAMPLE

Example: 150pf = 151
1500pf = 152
0.015 μ f = 153

Figure 1



89000 Series Dimensions (Figure 2)

Cap pf	D \emptyset mm	T mm	S mm	Cap pf	D \emptyset mm	T mm	S mm
1.0pf	4	4	2.5	220pf	4	4	2.5
1.5pf	4	4	2.5	330pf	4	4	2.5
2.0pf	4	4	2.5	470pf	4	4	2.5
3.0pf	4	4	2.5	680pf	4	4	2.5
5.0pf	4	4	2.5	820pf	5	4	2.5
6.0pf	4	4	2.5	1000pf	5	4	2.5
7.0pf	4	4	2.5	1200pf	5	4	2.5
8.0pf	4	4	2.5	1500pf	5	4	2.5
10pf	4	4	2.5	2200pf	5	4	2.5
12pf	4	4	2.5	3300pf	8	4	5.1
15pf	4	4	2.5	4700pf	8	4	5.1
18pf	5	4	2.5	5600pf	9.5	4	5.1
22pf	5	4	2.5	6800pf	9.5	4	5.1
33pf	5	4	2.5	8200pf	10.5	3	5.1
39pf	6.3	4	5.1	0.01 μ f	12.5	3	5.1
47pf	6.3	4	5.1	0.012 μ f	6.3	4	5.1
56pf	6.3	4	5.1	0.015 μ f	6.3	4	5.1
68pf	8	4	5.1	0.022 μ f	8	4	5.1
82pf	8	4	5.1	0.047 μ f	12.5	4	5.1
100pf	8	4	5.1	0.068 μ f	12.25	3.25	7.5
120pf	4	4	2.5	0.10 μ f	7.3	3.25	4.5

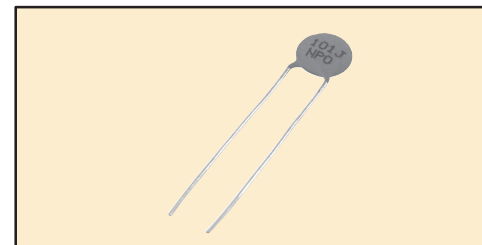
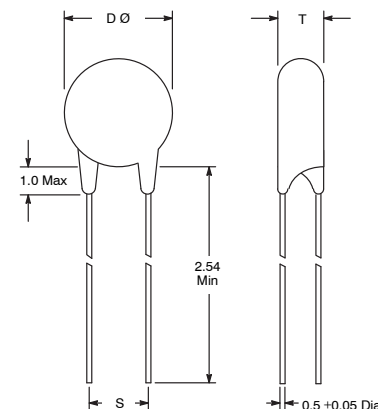

Figure 2



All dimensions are in mm