

User guide for FHS 40-P Current Transducer

FHS 40-P Kit 11 (G2.00.23.110.0)

Evaluation PCB

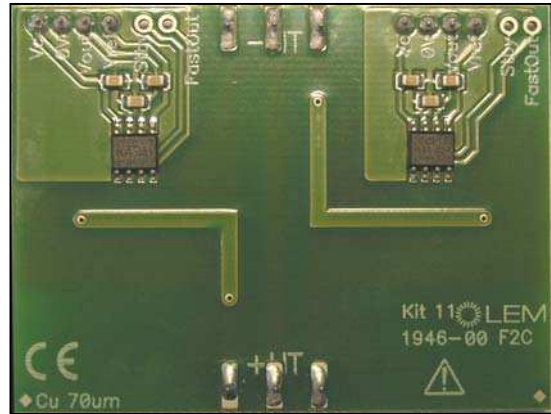

This evaluation board is based on a multi-turn design making possible a 2 phases measurement in a 3 phases system.

Terminals Pin-out

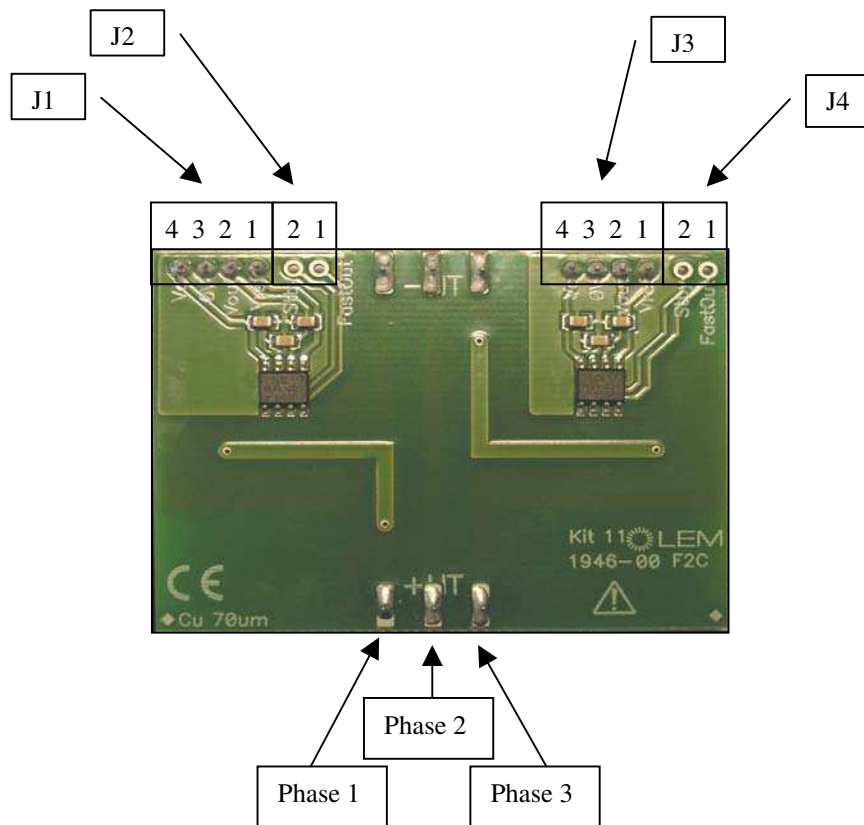

The board comprises two Minisens transducers, one for Phase 1 measurement, a second one for Phase 3; the Phase 2 in the centre is not measured.

Each Minisens has two single row terminals, J1 and J2 for Phase 1, J3 and J4 for Phase 3.

Manufacturer and reference for connectors: PRECI-DIP, 310-13-120-41-001001.

- The four pin one J1 (or J3) makes possible to supply the Minisens Phase 1 (or Phase 3) and access to its output voltage easily.

It has the following pin-out:

Pin #	Name	Description J1 or J3
1	V_{REF}	Reference voltage input/output
2	V_{OUT}	Output voltage is proportional to the current in the PCB track, $V_{OUT}=V_{REF}+G \cdot I_P$ Note that the output voltage is positive when the current flows inside the tracks according to the direction marked " $I_P \rightarrow$ " on the bottom side of the PCB
3	0	0 V
4	V_C	Positive supply voltage 4.75-5.25V; typical consumption 15 mA

- The two pin one J3 (or J4) makes possible to access to the fast output voltage and standby input easily. It has the following pin-out:

Pin #	Name	Description J2, J4
1	FastOut	Voutfast, fast output signal; note that this output is opposite to V_{OUT} (see datasheet for connection)
2	Standby	Standby, Set operating or Standby modes (see datasheet for connection)

Thermal Capability

The enclosed evaluation PCB has a thickness of 70 μm (2oz)

The dimensions of the tracks drawn on the evaluation PCB lead to some limitations on the max continuous current which can go through the PCB tracks.

Remark: Under normal operating conditions, temperature of some parts of this product might exceed 70 °C.

Primary track dimensions [mm]:

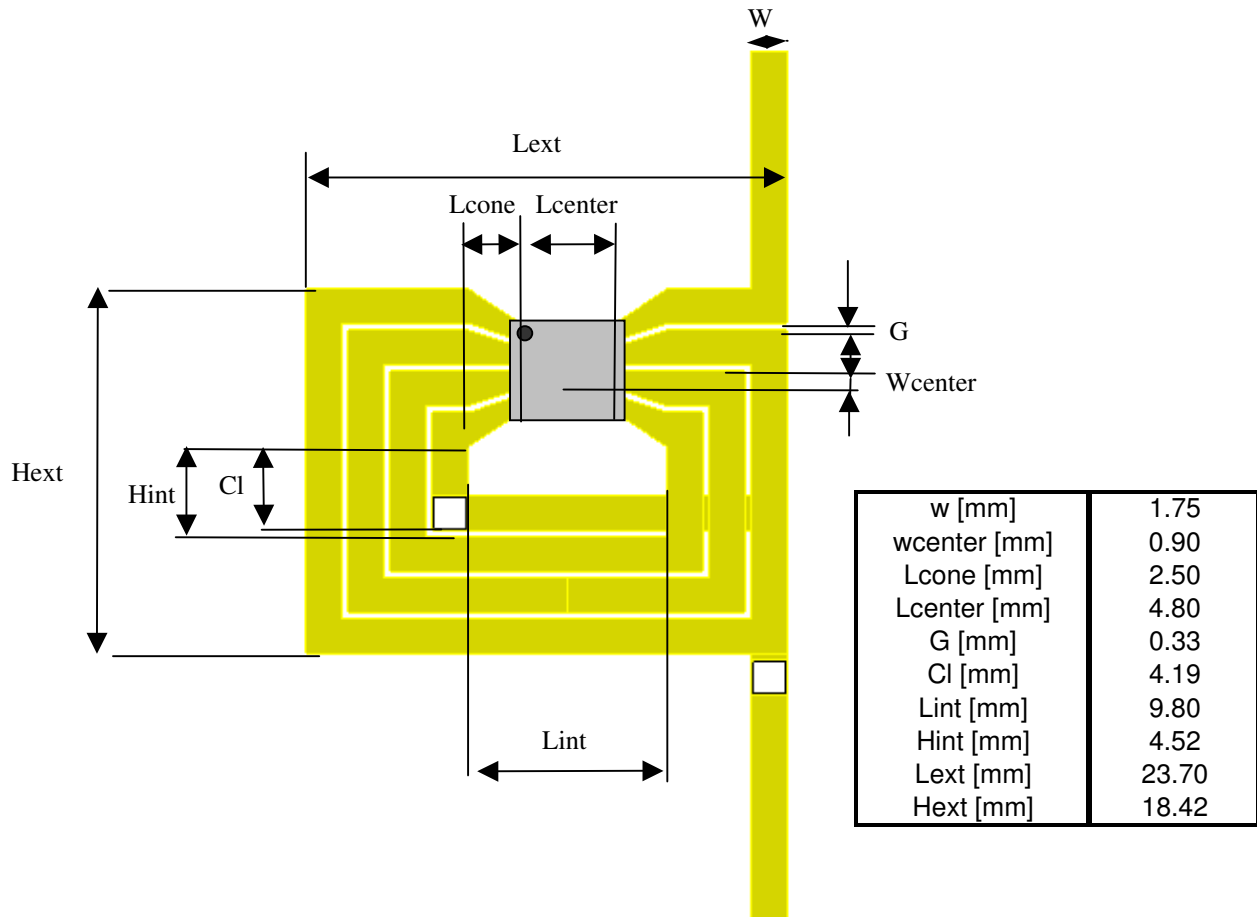

Thermal simulation:

Track thickness 70 μm (2 oz), PCB thickness 1.6 mm (0.062 inch), 70 degrees C ambient temperature, natural convection, $I_{PN} = 4$ A rms or DC. Under the above conditions, the temperature rise is 42 $^{\circ}\text{C}$.

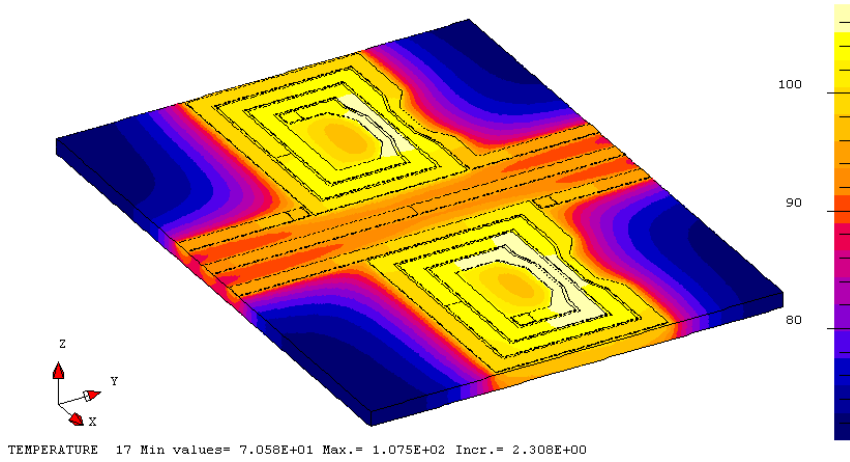

The following figures should be taken into account to avoid overheating:

(T primary track = 115 $^{\circ}\text{C}$)

Max rms Current I_p [A]	Cu 35 μm		Cu 70 μm	
	T_A [$^{\circ}\text{C}$]	ΔT [$^{\circ}\text{C}$]	T_A [$^{\circ}\text{C}$]	ΔT [$^{\circ}\text{C}$]
0	115	0	115	0
1	109.2	5.8	112.3	2.7
2	92.1	22.9	104.3	10.7
3	64.3	50.7	91.1	23.9
4	27.2	87.8	73	42
5	NA	NA	50.8	64.2

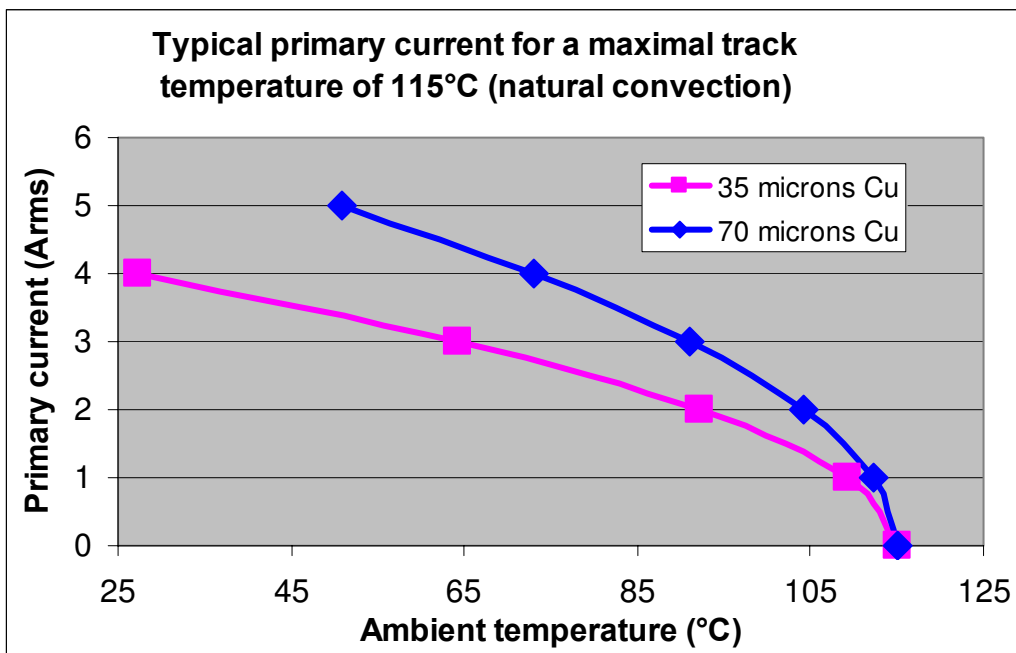

Perturbations phase to phase

Phase 1 on Phase 3 or Phase 2 on Phase 3

Typ. 0.29% of I_{PN}

Primary connection

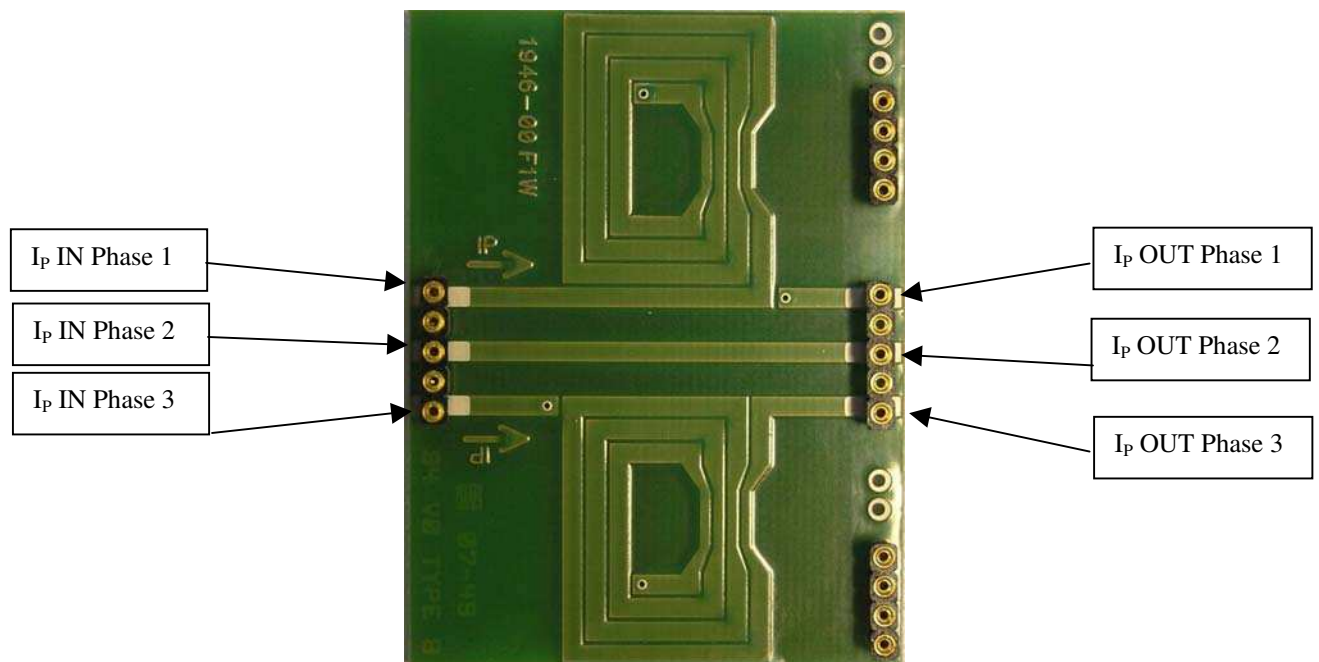

Connect then the primary phases according to the above picture, the positive direction being from I_P IN to I_P OUT.

Features:

Phase 1 or Phase 3

Magnetic Field Sensitivity	Typ. 600	mV/mT
Current Sensitivity	typ. 121.1 min (typ-3 σ) : 115.2 max (typ+3 σ) : 127.0	mV/A
Measuring range	typ. ± 16.5 Unless max rms current reached, see Thermal Capability.	A
Frequency range	DC – 100k	Hz

Isolation characteristics

	Symbol	Unit	Value
Rms voltage for AC isolation test, 50Hz, 1 min., between primary and secondary	V_D	kV	2.2
Impulse withstand voltage 1.2/50 μ s	V_W	kV	4.0
Creepage/Clearance distance	dCp/dCI	mm	3
Comparative tracking index (PCB FR4)	CTI	V	200

Application example

According to EN50178 and IEC61010-1 standards and following conditions:

- Rated isolation voltage 150V
- Reinforced isolation
- Over voltage category OV III
- Pollution degree PD1
- Non-uniform field

Safety



This transducer must be used in electric/electronic equipment with respect to applicable standards and safety requirements in accordance with the manufacturer's operating instructions.



Caution, risk of electrical shock

When operating the transducer, certain parts of the module can carry hazardous voltage (eg: primary busbar, power supply).

Ignoring this warning can lead to injury and/or cause serious damage.

This transducer is a built-in device, whose conducting parts must be inaccessible after installation.

A protective housing or additional shield could be used.

Main supply must be able to be disconnected.