

BFP720F

SiGe:C Heterojunction Wideband RF Bipolar Transistor

Data Sheet

Revision 1.0, 2009-03-13

Edition 2009-03-13

**Published by
Infineon Technologies AG
81726 Munich, Germany**

**© 2009 Infineon Technologies AG
All Rights Reserved.**

Legal Disclaimer

The information given in this document shall in no event be regarded as a guarantee of conditions or characteristics. With respect to any examples or hints given herein, any typical values stated herein and/or any information regarding the application of the device, Infineon Technologies hereby disclaims any and all warranties and liabilities of any kind, including without limitation, warranties of non-infringement of intellectual property rights of any third party.

Information

For further information on technology, delivery terms and conditions and prices, please contact the nearest Infineon Technologies Office (www.infineon.com).

Warnings

Due to technical requirements, components may contain dangerous substances. For information on the types in question, please contact the nearest Infineon Technologies Office.

Infineon Technologies components may be used in life-support devices or systems only with the express written approval of Infineon Technologies, if a failure of such components can reasonably be expected to cause the failure of that life-support device or system or to affect the safety or effectiveness of that device or system. Life support devices or systems are intended to be implanted in the human body or to support and/or maintain and sustain and/or protect human life. If they fail, it is reasonable to assume that the health of the user or other persons may be endangered.

BFP720F, SiGe:C Heterojunction Wideband RF Bipolar Transistor
Revision History: 2009-03-13, Revision 1.0
Previous Revision:

Page	Subjects (major changes since last revision)
	Converted to the new IFX Template.
	Business Unit, Infineon Logo and the Trademarks were changed.

Trademarks of Infineon Technologies AG

A-GOLD™, BlueMoon™, COMNEON™, CONVERGATE™, COSIC™, C166™, CROSSAVE™, CanPAK™, CIPOS™, CoolMOS™, CoolSET™, CONVERPATH™, CORECONTROL™, DAVE™, DUALFALC™, DUSLIC™, EasyPIM™, EconoBRIDGE™, EconoDUAL™, EconoPACK™, EconoPIM™, E-GOLD™, EiceDRIVER™, EUPEC™, ELIC™, EPIC™, FALC™, FCOS™, FLEXISLIC™, GEMINAX™, GOLDMOS™, HITFET™, HybridPACK™, INCA™, ISAC™, ISOFACE™, IsoPACK™, IWORX™, M-GOLD™, MIPAQ™, ModSTACK™, MUSLIC™, my-d™, NovalithIC™, OCTALFALC™, OCTAT™, OmniTune™, OmniVia™, OptiMOS™, OPTIVERSE™, ORIGA™, PROFET™, PRO-SIL™, PrimePACK™, QUADFALC™, RASIC™, ReverSave™, SatRIC™, SCEPTRE™, SCOUT™, S-GOLD™, SensoNor™, SEROCCO™, SICOFI™, SIEGET™, SINDRION™, SLIC™, SMARTi™, SmartLEWIS™, SMINT™, SOCRATES™, TEMPFET™, thinQ!™, TrueENTRY™, TriCore™, TRENCHSTOP™, VINAX™, VINETIC™, VIONTIC™, WildPass™, X-GOLD™, XMM™, X-PMU™, XPOSYS™, XWAY™.

Other Trademarks

AMBA™, ARM™, MULTI-ICE™, PRIMECELL™, REALVIEW™, THUMB™ of ARM Limited, UK. AUTOSAR™ is licensed by AUTOSAR development partnership. Bluetooth™ of Bluetooth SIG Inc. CAT-iq™ of DECT Forum. COLOSSUS™, FirstGPS™ of Trimble Navigation Ltd. EMV™ of EMVCo, LLC (Visa Holdings Inc.). EPCOS™ of Epcos AG. FLEXGO™ of Microsoft Corporation. FlexRay™ is licensed by FlexRay Consortium. HYPERTERMINAL™ of Hilgraeve Incorporated. IEC™ of Commission Electrotechnique Internationale. IrDA™ of Infrared Data Association Corporation. ISO™ of INTERNATIONAL ORGANIZATION FOR STANDARDIZATION. MATLAB™ of MathWorks, Inc. MAXIM™ of Maxim Integrated Products, Inc. MICROTEC™, NUCLEUS™ of Mentor Graphics Corporation. Mifare™ of NXP. MIPI™ of MIPI Alliance, Inc. MIPS™ of MIPS Technologies, Inc., USA. muRata™ of MURATA MANUFACTURING CO. OmniVision™ of OmniVision Technologies, Inc. Openwave™ Openwave Systems Inc. RED HAT™ Red Hat, Inc. RFMD™ RF Micro Devices, Inc. SIRIUS™ of Sirius Sattelite Radio Inc. SOLARIS™ of Sun Microsystems, Inc. SPANSION™ of Spansion LLC Ltd. Symbian™ of Symbian Software Limited. TAIYO YUDEN™ of Taiyo Yuden Co. TEAKLITE™ of CEVA, Inc. TEKTRONIX™ of Tektronix Inc. TOKO™ of TOKO KABUSHIKI KAISHA TA. UNIX™ of X/Open Company Limited. VERILOG™, PALLADIUM™ of Cadence Design Systems, Inc. VLYNQ™ of Texas Instruments Incorporated. VXWORKS™, WIND RIVER™ of WIND RIVER SYSTEMS, INC. ZETEX™ of Diodes Zetex Limited.

Last Trademarks Update 2009-10-19

Table of Contents

	Table of Contents	4
	List of Figures	5
	List of Tables	6
1	Features	7
2	Product Brief	8
3	Maximum Ratings	10
4	Thermal Characteristics	11
5	Electrical Characteristics	13
5.1	DC Characteristics	13
5.2	General AC Characteristics	13
5.3	Frequency Dependent AC Characteristics	14
5.4	Characteristic Curves	19
6	Simulation Data	24
7	Package Information	25

List of Figures

Figure 1	Total Power Dissipation $P_{\text{tot}} = f(T_s)$	11
Figure 2	Permissible Pulse Load $P_{\text{tot_max}} / P_{\text{tot_DC}} = f(t_p)$	12
Figure 3	Permissible Pulse Load $R_{\text{thJS}} = f(t_p)$	12
Figure 4	BFP720F Testing Circuit.	14
Figure 5	Transition Frequency $f_T = f(I_C, V_{CE}), f = 1 \text{ GHz}, V_{CE}$ Parameter in V.	19
Figure 6	Power Gain $G_{\text{ma}}, G_{\text{ms}}, S_{21} ^2 = f(\text{freq}), V_{CE} = 3 \text{ V}, I_C = 13 \text{ mA}$	19
Figure 7	Power Gain $G_{\text{ma}}, G_{\text{ms}} = f(I_C), V_{CE} = 3 \text{ V}, f = \text{Parameter in GHz}$	20
Figure 8	Power Gain $G_{\text{ma}}, G_{\text{ms}} = f(V_{CE}), I_C = 13 \text{ mA}, f = \text{Parameter in GHz}$	20
Figure 9	Input Matching $S_{11} = f(\text{freq}), V_{CE} = 3 \text{ V}, I_C = 5 \text{ mA} / 13 \text{ mA}$	21
Figure 10	Output Matching $S_{22} = f(\text{freq}), V_{CE} = 3 \text{ V}, I_C = 5 \text{ mA} / 13 \text{ mA}$	21
Figure 11	Source Impedance Z_{opt} for NF_{min} vs. Frequency, $V_{CE} = 3 \text{ V}, I_C = 5 \text{ mA} / 13 \text{ mA}$	22
Figure 12	Noise Figure $NF_{\text{min}} = f(I_C), V_{CE} = 3 \text{ V}, Z_S = Z_{\text{opt}}$	22
Figure 13	Noise Figure $NF_{\text{min}} = f(\text{freq}), V_{CE} = 3 \text{ V}, Z_S = Z_{\text{opt}}$	23
Figure 14	Package Outline TSFP-4(top / side view).	25
Figure 15	Footprint	25
Figure 16	Marking Example (Marking BFP720F: R9s)	25
Figure 17	Tape Dimensions	25

List of Tables

Table 1	Quick Reference DC Characteristics at $T_A = 25^\circ\text{C}$	8
Table 2	Quick Reference AC Characteristics at $T_A = 25^\circ\text{C}$	9
Table 3	Maximum Ratings at $T_A = 25^\circ\text{C}$ (unless otherwise specified).....	10
Table 4	Thermal Resistance	11
Table 5	DC Characteristics at $T_A = 25^\circ\text{C}$	13
Table 6	AC Characteristics at $T_A = 25^\circ\text{C}$	13
Table 7	AC Characteristics, $V_{CE} = 3\text{ V}, f = 150\text{ MHz}$	14
Table 8	AC Characteristics, $V_{CE} = 3\text{ V}, f = 450\text{ MHz}$	14
Table 9	AC Characteristics, $V_{CE} = 3\text{ V}, f = 900\text{ MHz}$	15
Table 10	AC Characteristics, $V_{CE} = 3\text{ V}, f = 1.5\text{ GHz}$	15
Table 11	AC Characteristics, $V_{CE} = 3\text{ V}, f = 1.9\text{ GHz}$	16
Table 12	AC Characteristics, $V_{CE} = 3\text{ V}, f = 2.4\text{ GHz}$	16
Table 13	AC Characteristics, $V_{CE} = 3\text{ V}, f = 3.5\text{ GHz}$	17
Table 14	AC Characteristics, $V_{CE} = 3\text{ V}, f = 5.5\text{ GHz}$	17
Table 15	AC Characteristics, $V_{CE} = 3\text{ V}, f = 10\text{ GHz}$	17

SiGe:C Heterojunction Wideband RF Bipolar Transistor

1 Features

Main features:

- High performance general purpose wideband LNA transistor
- 150 GHz fT-Silicon Germanium Carbon technology
- Enables Best-In-Class performance for wireless applications due to high dynamic range
- Transistor geometry optimized for low-current applications
- Operation voltage: 1.0 V to 4.0 V
- Very high gain at high frequencies and low current consumption
- 26.5 dB maximum stable gain at 1.9 GHz and only 13 mA
- 15 dB maximum available gain at 10 GHz and only 13 mA
- Ultra low noise figure from latest SiGe:C technology
- 0.7 dB minimum noise figure at 5.5 GHz and 1.0 dB at 10 GHz
- High linearity OP1dB = +7 dBm and OIP3 = +21 dBm at 5.5 GHz and low current consumption of 13 mA
- Pb-free (RoHS compliant) package

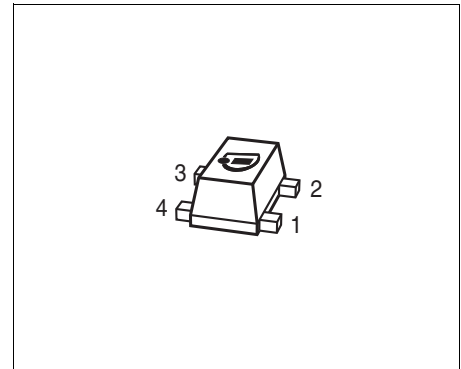

Applications

FM Radio, Mobile TV, RKE, AMR, Cellular, ZigBee, GPS, WiMAX, SDARs, Satellite Radio, Bluetooth, WiFi, Cordless phone, UMTS, WLAN, UWB, LNB.

Attention: ESD (Electrostatic discharge) sensitive device, observe handling precautions

Product Name	Package	Pin Configuration				Marking
BFP720F	TSFP-4	1 = B	2 = E	3 = C	4 = E	R9s

2 Product Brief

The BFP720F is a wideband Silicon Germanium Carbon (SiGe:C) NPN Heterojunction Bipolar Transistor (HBT) in a plastic 4-pin dual emitter TSFP-4 package. The device combines very high gain with lowest noise figure at low operating current for use in a wide range of wireless applications. The BFP720F is especially well-suited for portable battery-powered applications in which reduced power consumption is a key requirement. Collector design supports operation voltages from 1.0 V to 4.0 V.

Table 1 Quick Reference DC Characteristics at $T_A = 25^\circ\text{C}$

Parameter	Symbol	Values			Unit	Note / Test Condition
		Min.	Typ.	Max.		
Collector-emitter breakdown voltage	$V_{(BR)CEO}$	4	4.7	–	V	$I_C = 1 \text{ mA}, I_B = 0$
Collector-base breakdown voltage	$V_{(BR)CBO}$	13	15	–	V	$I_E = 0$
Collector current	I_C	–	–	25	mA	–
Total power dissipation	P_{tot}	–	–	100	mW	$T_S \leq 109^\circ\text{C}$
DC current gain	h_{FE}	160	250	400		$V_{CE} = 3 \text{ V}, I_C = 13 \text{ mA}$

Table 2 Quick Reference AC Characteristics at $T_A = 25^\circ\text{C}$

Parameter	Symbol	Values			Unit	Note / Test Condition
		Min.	Typ.	Max.		
Transition frequency	f_T	–	45	–	GHz	$V_{CE} = 3\text{ V}$, $I_C = 13\text{ mA}$, $f = 1\text{ GHz}$
$f = 2.4\text{ GHz}$						
Maximum Power Gain		–		–	dB	
Low Noise Operation Point	G_{ms}		22			$I_C = 5\text{ mA}$
High Linearity Operation Point	G_{ms}		25.5			$I_C = 13\text{ mA}$
Transducer Gain		–		–	dB	$Z_S = Z_L = 50\ \Omega$
Low Noise Operation Point	S_{21}		20.5			$I_C = 5\text{ mA}$
High Linearity Operation Point	S_{21}		23			$I_C = 13\text{ mA}$
Minimum Noise Figure		–		–	dB	$Z_S = Z_{opt}$
Minimum Noise Figure	NF_{min}		0.55			$I_C = 5\text{ mA}$
Associated Gain	G_{ass}		22			$I_C = 5\text{ mA}$
Linearity		–		–	dBm	$Z_S = Z_L = 50\ \Omega$
1 dB Gain Compression Point	OP_{1dB}		6			$I_C = 13\text{ mA}$
3 rd Order Intercept Point	OIP_3		21			$I_C = 13\text{ mA}$
$f = 5.5\text{ GHz}$						
Maximum Power Gain		–		–	dB	
Low Noise Operation Point	G_{ms}		19			$I_C = 5\text{ mA}$
High Linearity Operation Point	G_{ms}		21.5			$I_C = 13\text{ mA}$
Transducer Gain		–		–	dB	$Z_S = Z_L = 50\ \Omega$
Low Noise Operation Point	S_{21}		15			$I_C = 5\text{ mA}$
High Linearity Operation Point	S_{21}		16.5			$I_C = 13\text{ mA}$
Minimum Noise Figure		–		–	dB	$Z_S = Z_{opt}$
Minimum Noise Figure	NF_{min}		0.7			$I_C = 5\text{ mA}$
Associated Gain	G_{ass}		15			$I_C = 5\text{ mA}$
Linearity		–		–	dBm	$Z_S = Z_L = 50\ \Omega$
1 dB Gain Compression Point	OP_{1dB}		7			$I_C = 13\text{ mA}$
3 rd Order Intercept Point	OIP_3		21			$I_C = 13\text{ mA}$

3 Maximum Ratings

Table 3 Maximum Ratings at $T_A = 25^\circ\text{C}$ (unless otherwise specified)

Parameter	Symbol	Values		Unit	Note / Test Condition
		Min.	Max.		
Collector-emitter voltage $T_A = -55^\circ\text{C}$	V_{CEO}	–	4.0	V	
Collector-emitter voltage	V_{CES}	–	13	V	
Collector-base voltage	V_{CBO}	–	13	V	
Emitter-base voltage	V_{EBO}	–	1.2	V	
Collector current	I_C	–	25	mA	
Base current	I_B	–	2	mA	
Total power dissipation ¹⁾ $T_S \leq 109^\circ\text{C}$	P_{tot}	–	100	mW	
Operation junction temperature	T_{JOp}	-55	150	$^\circ\text{C}$	
Storage temperature	T_{Stg}	-55	150	$^\circ\text{C}$	

1) T_S is the soldering temperature. T_S measured on the emitter lead at the soldering point of the pcb.

Note: Exceeding only one of the above maximum rating limits even for a short moment may cause permanent damage to the device. Even if the device continues to operate, its lifetime may be considerably shortened. Maximum ratings are stress ratings only and do not mean unaffected functional operation and lifetime at others than standard operation conditions.

4 Thermal Characteristics

Table 4 Thermal Resistance

Parameter	Symbol	Values			Unit	Note / Test Condition
		Min.	Typ.	Max.		
Junction - soldering point ¹⁾	R_{thJS}	–	410	–	K/W	–

1) For calculation of R_{thJA} please refer to Application Note Thermal Resistance

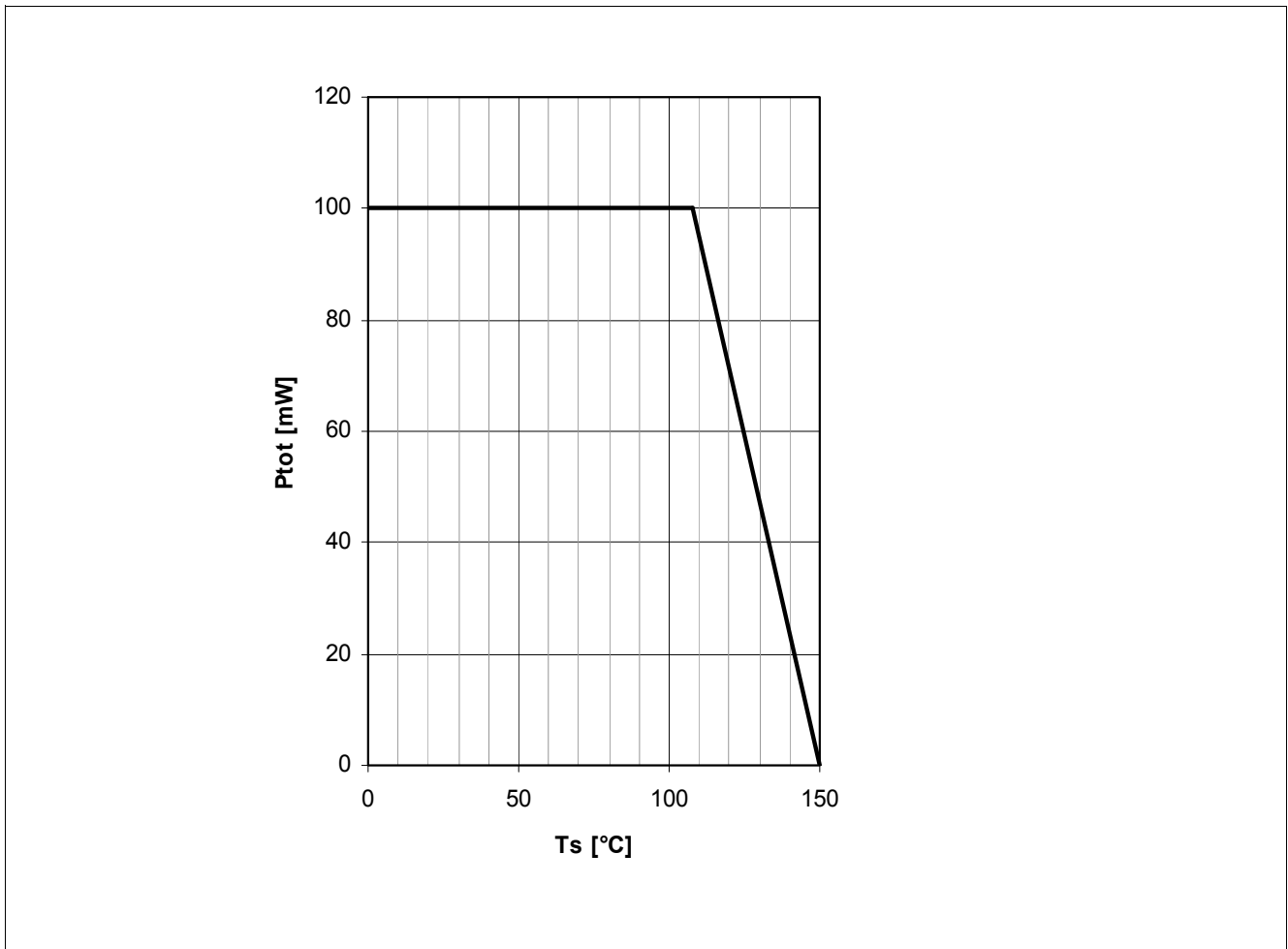

Figure 1 Total Power Dissipation $P_{tot} = f(T_s)$

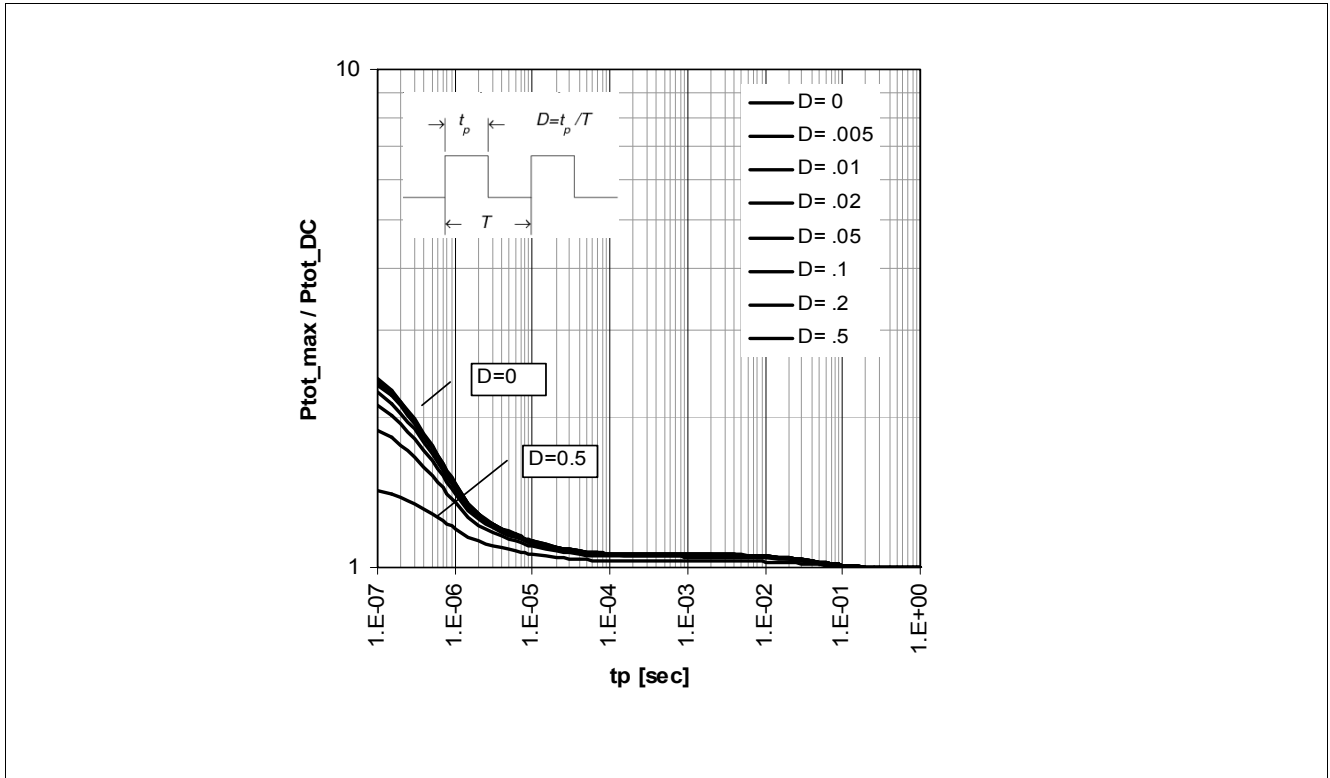

Figure 2 Permissible Pulse Load $P_{tot_max} / P_{tot_DC} = f(t_p)$

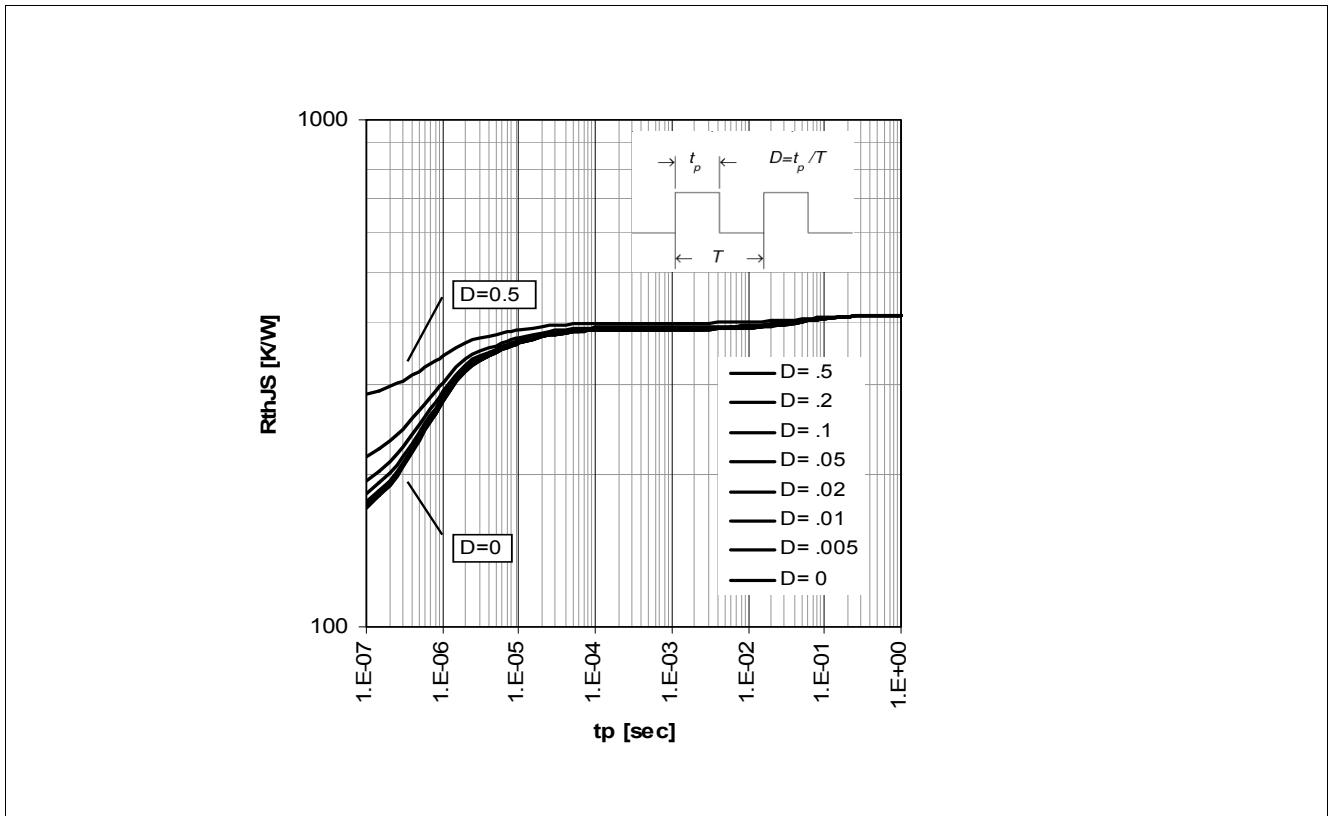

Figure 3 Permissible Pulse Load $R_{thJS} = f(t_p)$

5 Electrical Characteristics

5.1 DC Characteristics

Table 5 DC Characteristics at $T_A = 25\text{ °C}$

Parameter	Symbol	Values			Unit	Note / Test Condition
		Min.	Typ.	Max.		
Collector-emitter breakdown voltage	$V_{(BR)CEO}$	4	4.7	–	V	$I_C = 1\text{ mA}, I_B = 0$
Collector-emitter cutoff current	I_{CES}	–	–	30	μA	$V_{CE} = 13\text{ V}, V_{BE} = 0\text{ V}$
Collector-base cutoff current	I_{CBO}	–	–	100	nA	$V_{CB} = 5\text{ V}, I_E = 0$
Emitter-base cutoff current	I_{EBO}	–	–	2	μA	$V_{EB} = 0.5\text{ V}, I_C = 0$
DC current gain	h_{FE}	160	250	400		$I_C = 13\text{ mA}, V_{CE} = 3\text{ V}$ pulse measured

5.2 General AC Characteristics

Table 6 AC Characteristics at $T_A = 25\text{ °C}$

Parameter	Symbol	Values			Unit	Note / Test Condition
		Min.	Typ.	Max.		
Transition frequency	f_T	–	45	–	GHz	$I_C = 13\text{ mA}, V_{CE} = 3\text{ V}$ $f = 1\text{ GHz}$
Collector-base capacitance	C_{cb}	–	0.06	–	pF	$V_{CB} = 3\text{ V}, V_{BE} = 0\text{ V}$ $f = 1\text{ MHz}$ emitter grounded
Collector-emitter capacitance	C_{ce}	–	0.3	–	pF	$V_{CE} = 3\text{ V}, V_{BE} = 0\text{ V}$ $f = 1\text{ MHz}$ base grounded
Emitter-base capacitance	C_{eb}	–	0.3	–	pF	$V_{EB} = 0.5\text{ V}, V_{CB} = 0\text{ V}$ $f = 1\text{ MHz}$ collector grounded

5.3 Frequency Dependent AC Characteristics

Measurement setup is a testfixture with Bias T's in a 50 Ω system, $T_A = 25\text{ °C}$

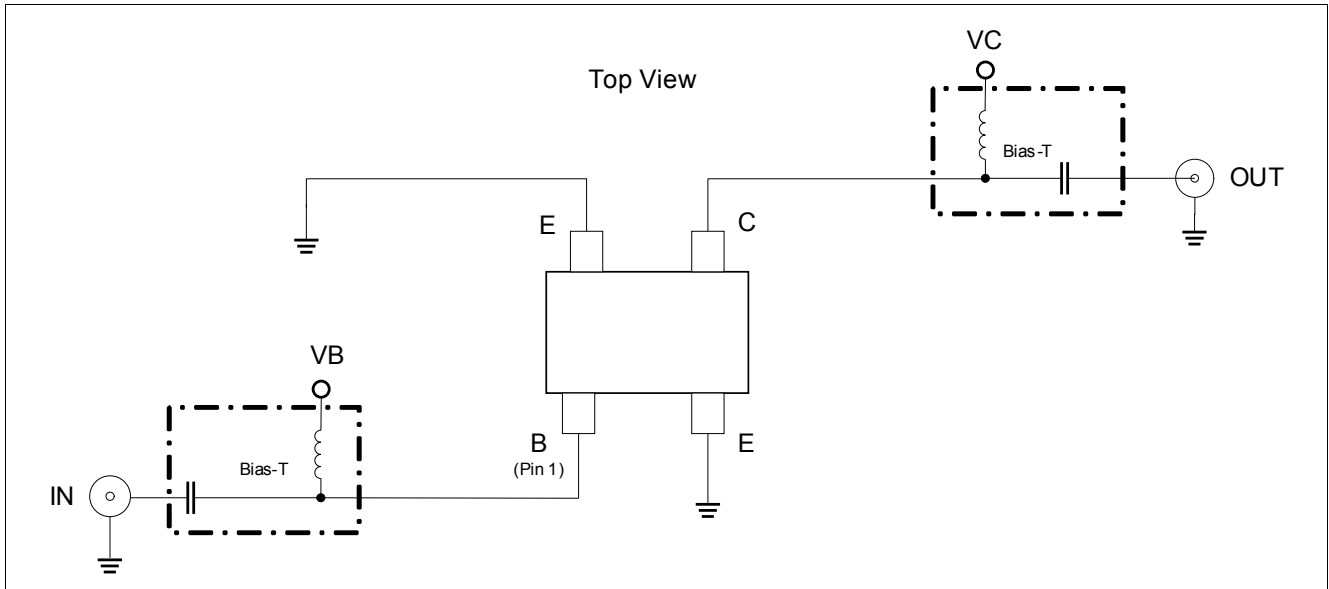

Figure 4 BFP720F Testing Circuit

Table 7 AC Characteristics, $V_{CE} = 3\text{ V}$, $f = 150\text{ MHz}$

Parameter	Symbol	Values			Unit	Note / Test Condition
		Min.	Typ.	Max.		
Maximum Power Gain					dB	
Low Noise Operation Point	G_{ms}	–	34	–		$I_C = 5\text{ mA}$
High Linearity Operation Point	G_{ms}	–	37.5	–		$I_C = 13\text{ mA}$
Transducer Gain					dB	$Z_S = Z_L = 50\text{ }\Omega$
Low Noise Operation Point	S_{21}	–	23	–		$I_C = 5\text{ mA}$
High Linearity Operation Point	S_{21}	–	29	–		$I_C = 13\text{ mA}$
Minimum Noise Figure					dB	$Z_S = Z_{opt}$
Minimum Noise Figure	NF_{min}	–	0.4	–		$I_C = 5\text{ mA}$
Associated Gain	G_{ass}	–	28	–		$I_C = 5\text{ mA}$
Linearity					dBm	$Z_S = Z_L = 50\text{ }\Omega$
1 dB Gain Compression Point	OP_{1dB}	–	6	–		$I_C = 13\text{ mA}$
3rd Order Intercept Point	OIP_3	–	22.5	–		$I_C = 13\text{ mA}$

Table 8 AC Characteristics, $V_{CE} = 3\text{ V}$, $f = 450\text{ MHz}$

Parameter	Symbol	Values			Unit	Note / Test Condition
		Min.	Typ.	Max.		
Maximum Power Gain					dB	
Low Noise Operation Point	G_{ms}	–	29	–		$I_C = 5\text{ mA}$
High Linearity Operation Point	G_{ms}	–	32.5	–		$I_C = 13\text{ mA}$

Electrical Characteristics
Table 8 AC Characteristics, $V_{CE} = 3\text{ V}$, $f = 450\text{ MHz}$ (cont'd)

Parameter	Symbol	Values			Unit	Note / Test Condition
		Min.	Typ.	Max.		
Transducer Gain					dB	$Z_S = Z_L = 50\ \Omega$
Low Noise Operation Point	S_{21}	–	22.5	–		$I_C = 5\text{ mA}$
High Linearity Operation Point	S_{21}	–	28.5	–		$I_C = 13\text{ mA}$
Minimum Noise Figure					dB	$Z_S = Z_{opt}$
Minimum Noise Figure	NF_{min}	–	0.4	–		$I_C = 5\text{ mA}$
Associated Gain	G_{ass}	–	27.5	–		$I_C = 5\text{ mA}$
Linearity					dBm	$Z_S = Z_L = 50\ \Omega$
1 dB Gain Compression Point	OP_{1dB}	–	5.5	–		$I_C = 13\text{ mA}$
3rd Order Intercept Point	OIP_3	–	21.5	–		$I_C = 13\text{ mA}$

Table 9 AC Characteristics, $V_{CE} = 3\text{ V}$, $f = 900\text{ MHz}$

Parameter	Symbol	Values			Unit	Note / Test Condition
		Min.	Typ.	Max.		
Maximum Power Gain					dB	
Low Noise Operation Point	G_{ms}	–	26.5	–		$I_C = 5\text{ mA}$
High Linearity Operation Point	G_{ms}	–	29.5	–		$I_C = 13\text{ mA}$
Transducer Gain					dB	$Z_S = Z_L = 50\ \Omega$
Low Noise Operation Point	S_{21}	–	22.5	–		$I_C = 5\text{ mA}$
High Linearity Operation Point	S_{21}	–	27.5	–		$I_C = 13\text{ mA}$
Minimum Noise Figure					dB	$Z_S = Z_{opt}$
Minimum Noise Figure	NF_{min}	–	0.45	–		$I_C = 5\text{ mA}$
Associated Gain	G_{ass}	–	25.5	–		$I_C = 5\text{ mA}$
Linearity					dBm	$Z_S = Z_L = 50\ \Omega$
1 dB Gain Compression Point	OP_{1dB}	–	5.5	–		$I_C = 13\text{ mA}$
3rd Order Intercept Point	OIP_3	–	20.5	–		$I_C = 13\text{ mA}$

Table 10 AC Characteristics, $V_{CE} = 3\text{ V}$, $f = 1.5\text{ GHz}$

Parameter	Symbol	Values			Unit	Note / Test Condition
		Min.	Typ.	Max.		
Maximum Power Gain					dB	
Low Noise Operation Point	G_{ms}	–	24	–		$I_C = 5\text{ mA}$
High Linearity Operation Point	G_{ms}	–	27.5	–		$I_C = 13\text{ mA}$
Transducer Gain					dB	$Z_S = Z_L = 50\ \Omega$
Low Noise Operation Point	S_{21}	–	21.5	–		$I_C = 5\text{ mA}$
High Linearity Operation Point	S_{21}	–	26	–		$I_C = 13\text{ mA}$
Minimum Noise Figure					dB	$Z_S = Z_{opt}$
Minimum Noise Figure	NF_{min}	–	0.45	–		$I_C = 5\text{ mA}$

Electrical Characteristics
Table 10 AC Characteristics, $V_{CE} = 3\text{ V}$, $f = 1.5\text{ GHz}$ (cont'd)

Parameter	Symbol	Values			Unit	Note / Test Condition
		Min.	Typ.	Max.		
Associated Gain	G_{ass}	–	24	–		$I_C = 5\text{ mA}$
Linearity					dBm	$Z_S = Z_L = 50\ \Omega$
1 dB Gain Compression Point	OP_{1dB}	–	6	–		$I_C = 13\text{ mA}$
3rd Order Intercept Point	OIP_3	–	21	–		$I_C = 13\text{ mA}$

Table 11 AC Characteristics, $V_{CE} = 3\text{ V}$, $f = 1.9\text{ GHz}$

Parameter	Symbol	Values			Unit	Note / Test Condition
		Min.	Typ.	Max.		
Maximum Power Gain					dB	
Low Noise Operation Point	G_{ms}	–	23	–		$I_C = 5\text{ mA}$
High Linearity Operation Point	G_{ms}	–	26.5	–		$I_C = 13\text{ mA}$
Transducer Gain					dB	$Z_S = Z_L = 50\ \Omega$
Low Noise Operation Point	S_{21}	–	21	–		$I_C = 5\text{ mA}$
High Linearity Operation Point	S_{21}	–	24.5	–		$I_C = 13\text{ mA}$
Minimum Noise Figure					dB	$Z_S = Z_{opt}$
Minimum Noise Figure	NF_{min}	–	0.5	–		$I_C = 5\text{ mA}$
Associated Gain	G_{ass}	–	23	–		$I_C = 5\text{ mA}$
Linearity					dBm	$Z_S = Z_L = 50\ \Omega$
1 dB Gain Compression Point	OP_{1dB}	–	6.5	–		$I_C = 13\text{ mA}$
3rd Order Intercept Point	OIP_3	–	21	–		$I_C = 13\text{ mA}$

Table 12 AC Characteristics, $V_{CE} = 3\text{ V}$, $f = 2.4\text{ GHz}$

Parameter	Symbol	Values			Unit	Note / Test Condition
		Min.	Typ.	Max.		
Maximum Power Gain					dB	
Low Noise Operation Point	G_{ms}	–	22	–		$I_C = 5\text{ mA}$
High Linearity Operation Point	G_{ms}	–	25.5	–		$I_C = 13\text{ mA}$
Transducer Gain					dB	$Z_S = Z_L = 50\ \Omega$
Low Noise Operation Point	S_{21}	–	20.5	–		$I_C = 5\text{ mA}$
High Linearity Operation Point	S_{21}	–	23	–		$I_C = 13\text{ mA}$
Minimum Noise Figure					dB	$Z_S = Z_{opt}$
Minimum Noise Figure	NF_{min}	–	0.55	–		$I_C = 5\text{ mA}$
Associated Gain	G_{ass}	–	22	–		$I_C = 5\text{ mA}$
Linearity					dBm	$Z_S = Z_L = 50\ \Omega$
1 dB Gain Compression Point	OP_{1dB}	–	6	–		$I_C = 13\text{ mA}$
3rd Order Intercept Point	OIP_3	–	21	–		$I_C = 13\text{ mA}$

Electrical Characteristics
Table 13 AC Characteristics, $V_{CE} = 3\text{ V}$, $f = 3.5\text{ GHz}$

Parameter	Symbol	Values			Unit	Note / Test Condition
		Min.	Typ.	Max.		
Maximum Power Gain						
Low Noise Operation Point	G_{ms}	–	20.5	–	dB	$I_C = 5\text{ mA}$
High Linearity Operation Point	G_{ms}	–	23.5	–		$I_C = 13\text{ mA}$
Transducer Gain						
Low Noise Operation Point	S_{21}	–	18	–	dB	$Z_S = Z_L = 50\ \Omega$ $I_C = 5\text{ mA}$
High Linearity Operation Point	S_{21}	–	20.5	–		$I_C = 13\text{ mA}$
Minimum Noise Figure						
Minimum Noise Figure	NF_{min}	–	0.6	–	dB	$Z_S = Z_{opt}$ $I_C = 5\text{ mA}$
Associated Gain	G_{ass}	–	19.5	–		$I_C = 5\text{ mA}$
Linearity						
1 dB Gain Compression Point	OP_{1dB}	–	6.5	–	dBm	$Z_S = Z_L = 50\ \Omega$ $I_C = 13\text{ mA}$
3rd Order Intercept Point	OIP_3	–	21.5	–		$I_C = 13\text{ mA}$

Table 14 AC Characteristics, $V_{CE} = 3\text{ V}$, $f = 5.5\text{ GHz}$

Parameter	Symbol	Values			Unit	Note / Test Condition
		Min.	Typ.	Max.		
Maximum Power Gain						
Low Noise Operation Point	G_{ms}	–	19	–	dB	$I_C = 5\text{ mA}$
High Linearity Operation Point	G_{ms}	–	21.5	–		$I_C = 13\text{ mA}$
Transducer Gain						
Low Noise Operation Point	S_{21}	–	15	–	dB	$Z_S = Z_L = 50\ \Omega$ $I_C = 5\text{ mA}$
High Linearity Operation Point	S_{21}	–	16.5	–		$I_C = 13\text{ mA}$
Minimum Noise Figure						
Minimum Noise Figure	NF_{min}	–	0.7	–	dB	$Z_S = Z_{opt}$ $I_C = 5\text{ mA}$
Associated Gain	G_{ass}	–	15	–		$I_C = 5\text{ mA}$
Linearity						
1 dB Gain Compression Point	OP_{1dB}	–	7	–	dBm	$Z_S = Z_L = 50\ \Omega$ $I_C = 13\text{ mA}$
3rd Order Intercept Point	OIP_3	–	21	–		$I_C = 13\text{ mA}$

Table 15 AC Characteristics, $V_{CE} = 3\text{ V}$, $f = 10\text{ GHz}$

Parameter	Symbol	Values			Unit	Note / Test Condition
		Min.	Typ.	Max.		
Maximum Power Gain						
Low Noise Operation Point	G_{ma}	–	14	–	dB	$I_C = 5\text{ mA}$
High Linearity Operation Point	G_{ma}	–	15	–		$I_C = 13\text{ mA}$
Transducer Gain						
Low Noise Operation Point	S_{21}	–	9.5	–	dB	$Z_S = Z_L = 50\ \Omega$ $I_C = 5\text{ mA}$

Table 15 AC Characteristics, $V_{CE} = 3\text{ V}$, $f = 10\text{ GHz}$ (cont'd)

Parameter	Symbol	Values			Unit	Note / Test Condition
		Min.	Typ.	Max.		
High Linearity Operation Point	S_{21}	–	10.5	–		$I_C = 13\text{ mA}$
Minimum Noise Figure					dB	$Z_S = Z_{opt}$
Minimum Noise Figure	NF_{min}	–	1.0	–		$I_C = 5\text{ mA}$
Associated Gain	G_{ass}	–	10.5	–		$I_C = 5\text{ mA}$
Linearity					dBm	$Z_S = Z_L = 50\ \Omega$
1 dB Gain Compression Point	OP_{1dB}	–	8	–		$I_C = 13\text{ mA}$
3rd Order Intercept Point	OIP_3	–	19.5	–		$I_C = 13\text{ mA}$

Note:

1. $G_{ms} = |S_{21} / S_{12}|$ for $k < 1$; $G_{ma} = |S_{21} / S_{12}|(k - (k^2 - 1)^{1/2})$ for $k > 1$
2. In order to get the NF_{min} values stated in this chapter the test fixture losses have been subtracted from all measured results

5.4 Characteristic Curves

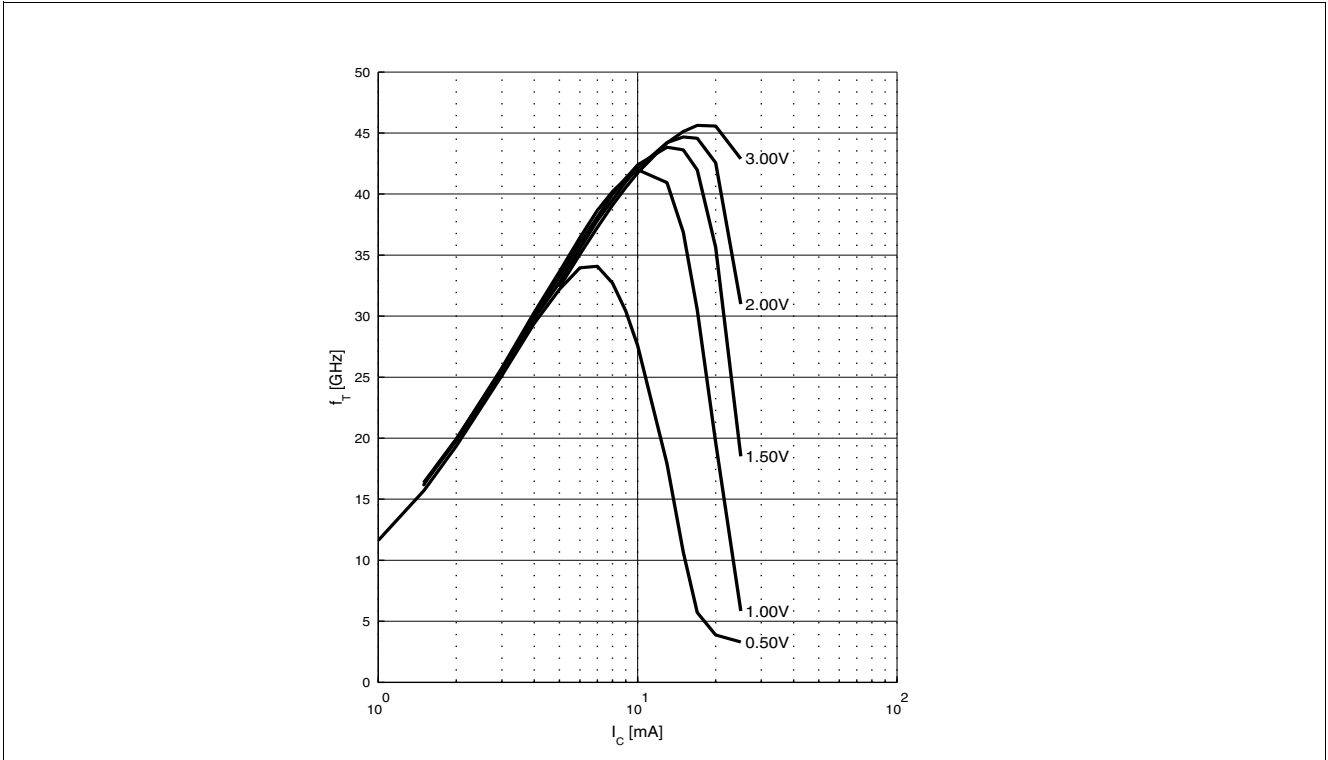

Figure 5 Transition Frequency $f_T = f(I_C, V_{CE})$, $f = 1 \text{ GHz}$, V_{CE} Parameter in V

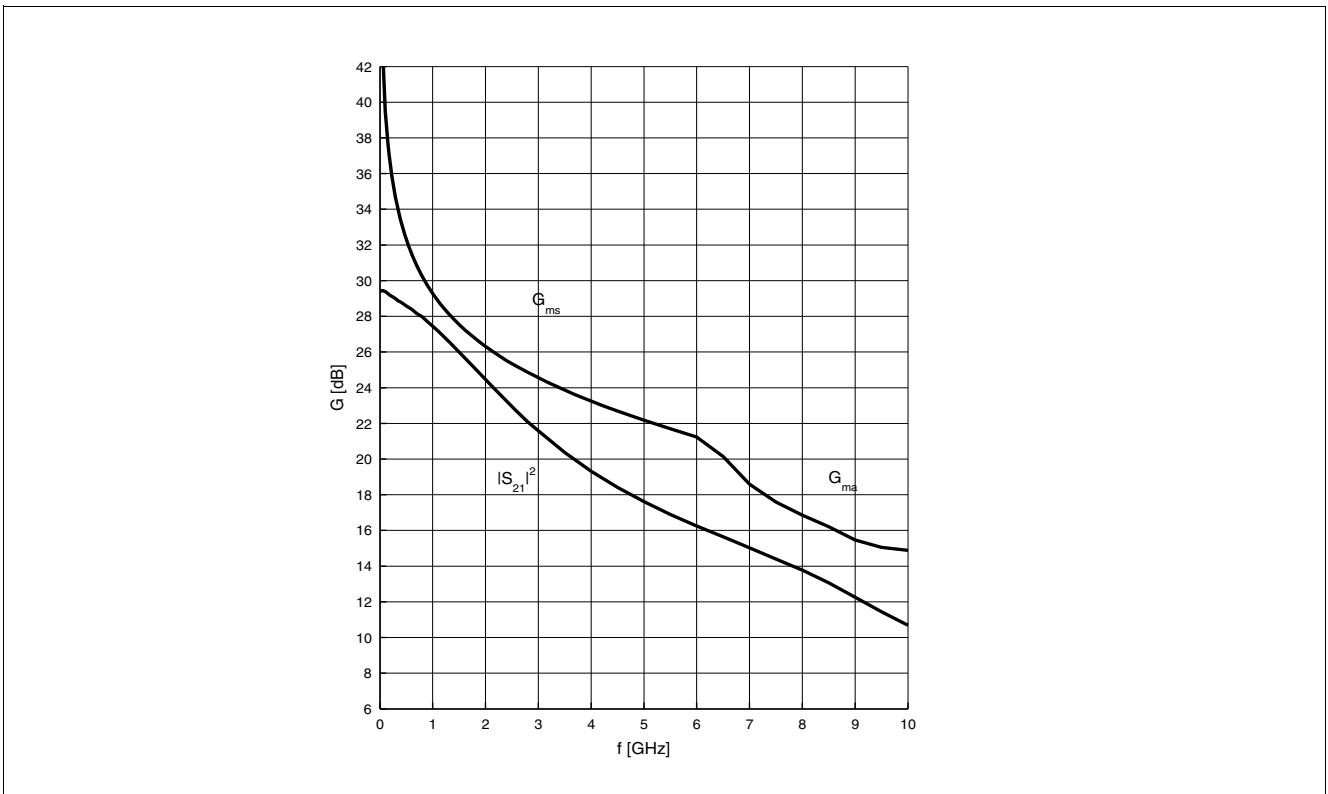

Figure 6 Power Gain G_{ma} , G_{ms} , $|S_{21}|^2 = f(\text{freq})$, $V_{CE} = 3 \text{ V}$, $I_C = 13 \text{ mA}$

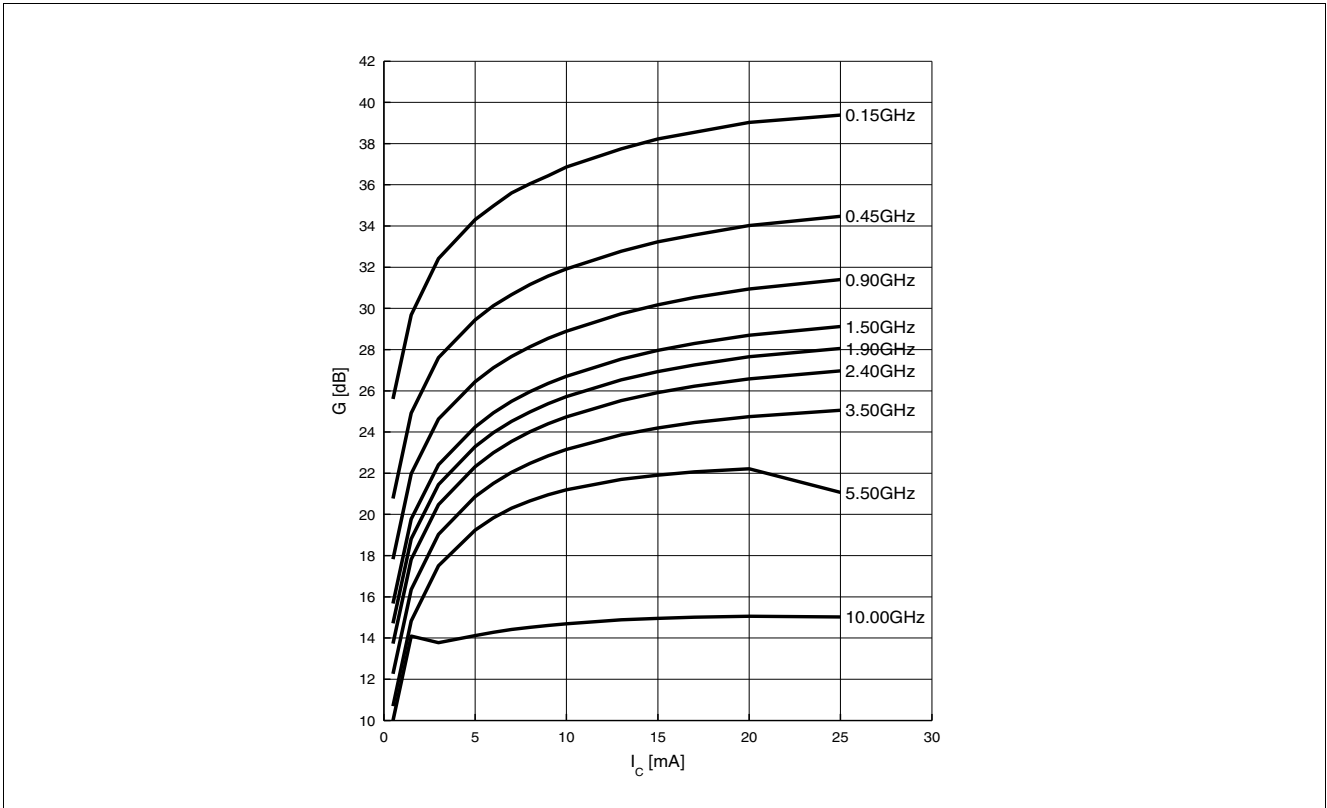

Figure 7 Power Gain G_{ma} , $G_{ms} = f(I_c)$, $V_{CE} = 3\text{ V}$, $f = \text{Parameter in GHz}$

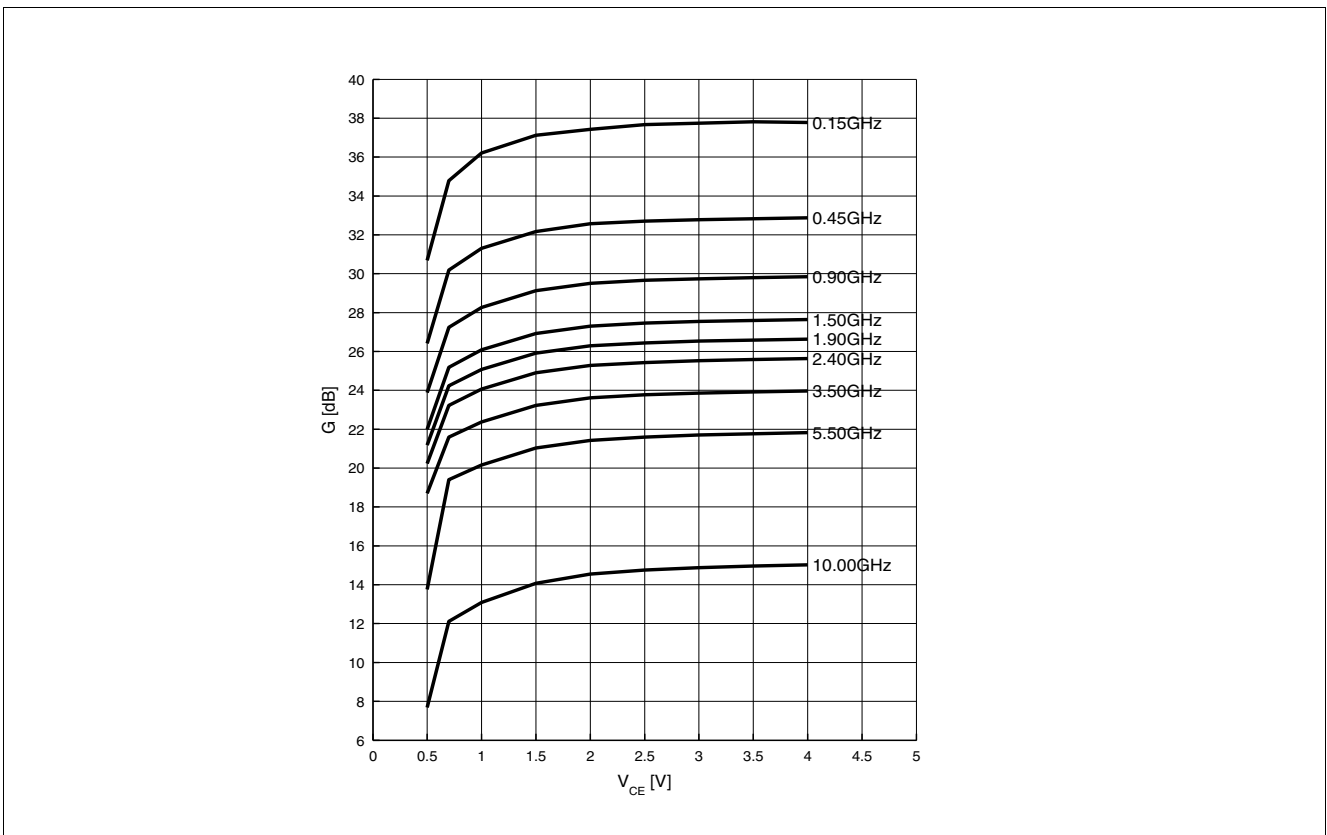

Figure 8 Power Gain G_{ma} , $G_{ms} = f(V_{CE})$, $I_c = 13\text{ mA}$, $f = \text{Parameter in GHz}$

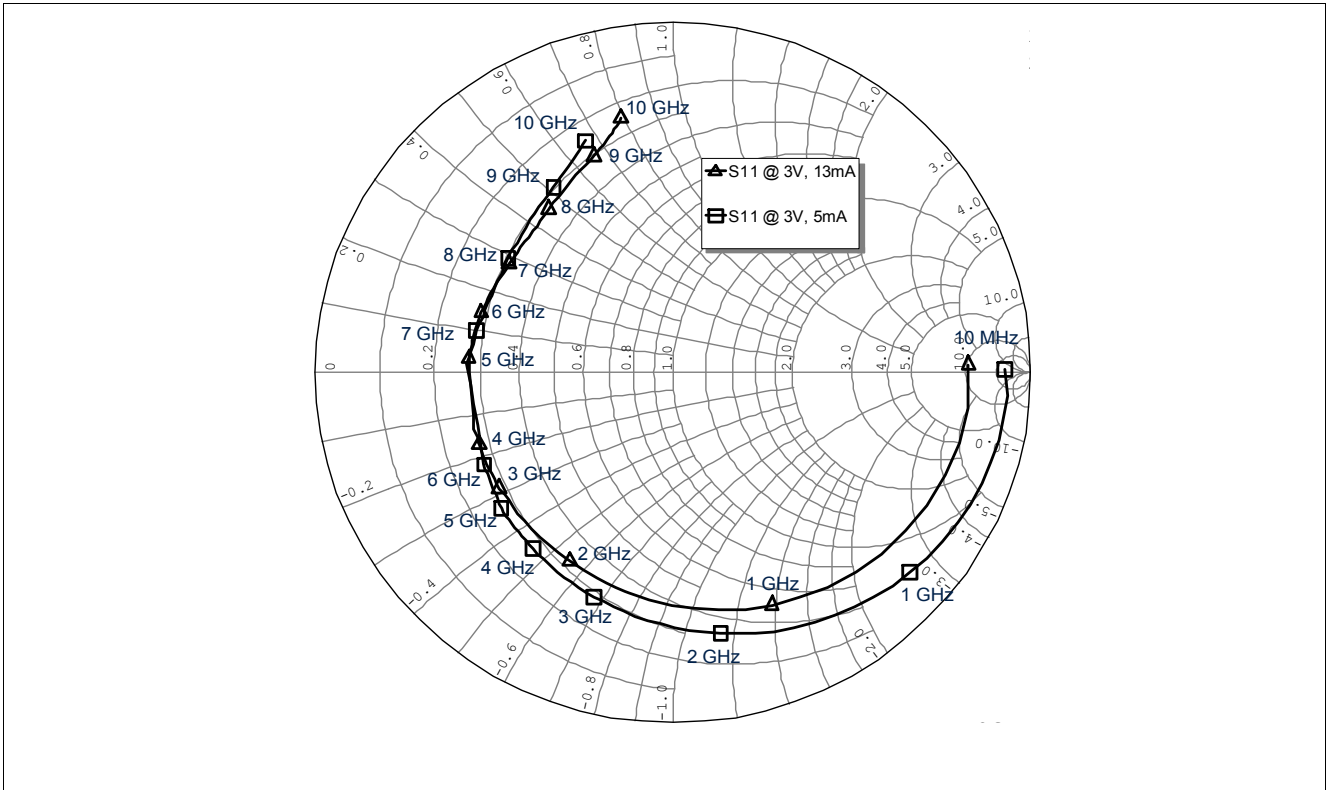

Figure 9 Input Matching $S_{11} = f(\text{freq})$, $V_{CE} = 3 \text{ V}$, $I_C = 5 \text{ mA} / 13 \text{ mA}$

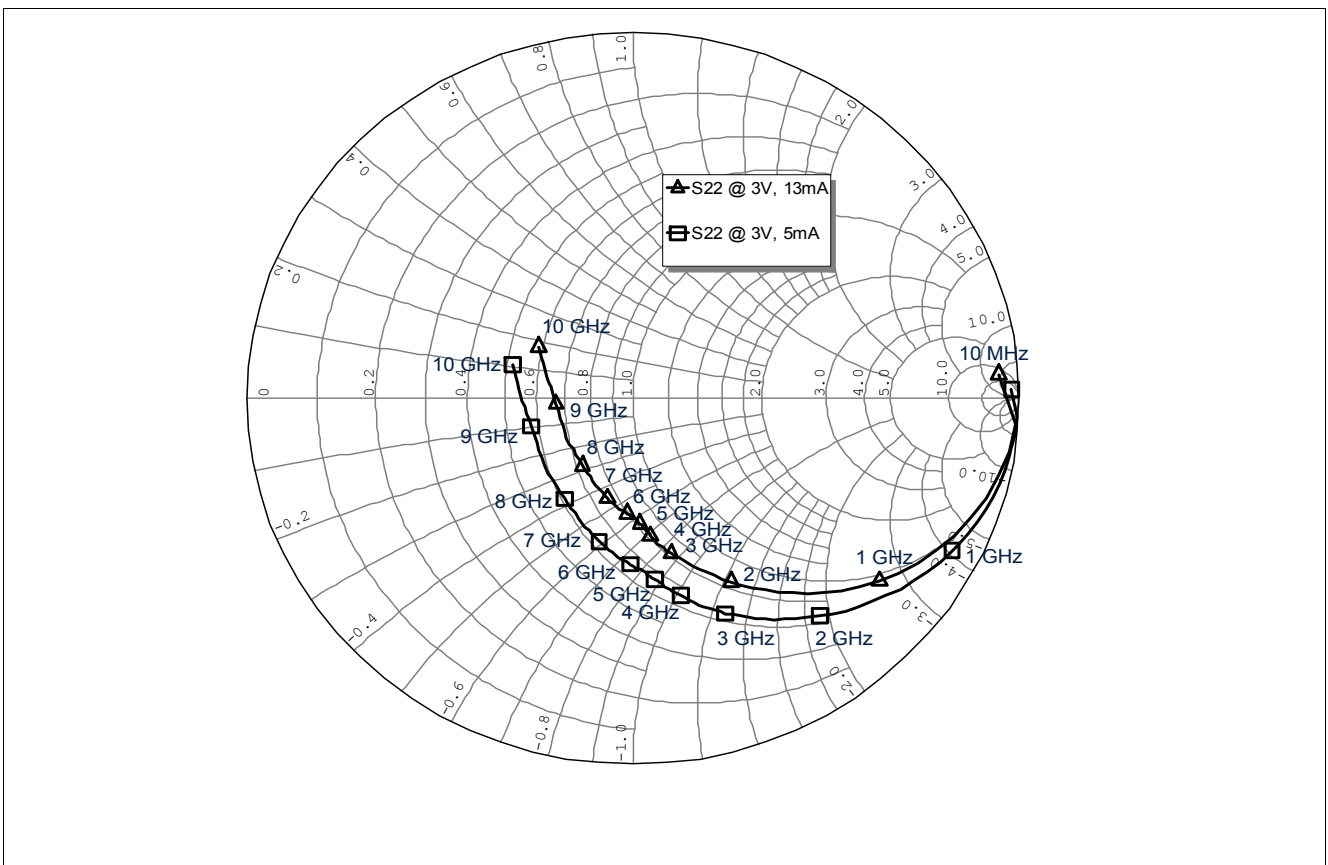

Figure 10 Output Matching $S_{22} = f(\text{freq})$, $V_{CE} = 3 \text{ V}$, $I_C = 5 \text{ mA} / 13 \text{ mA}$

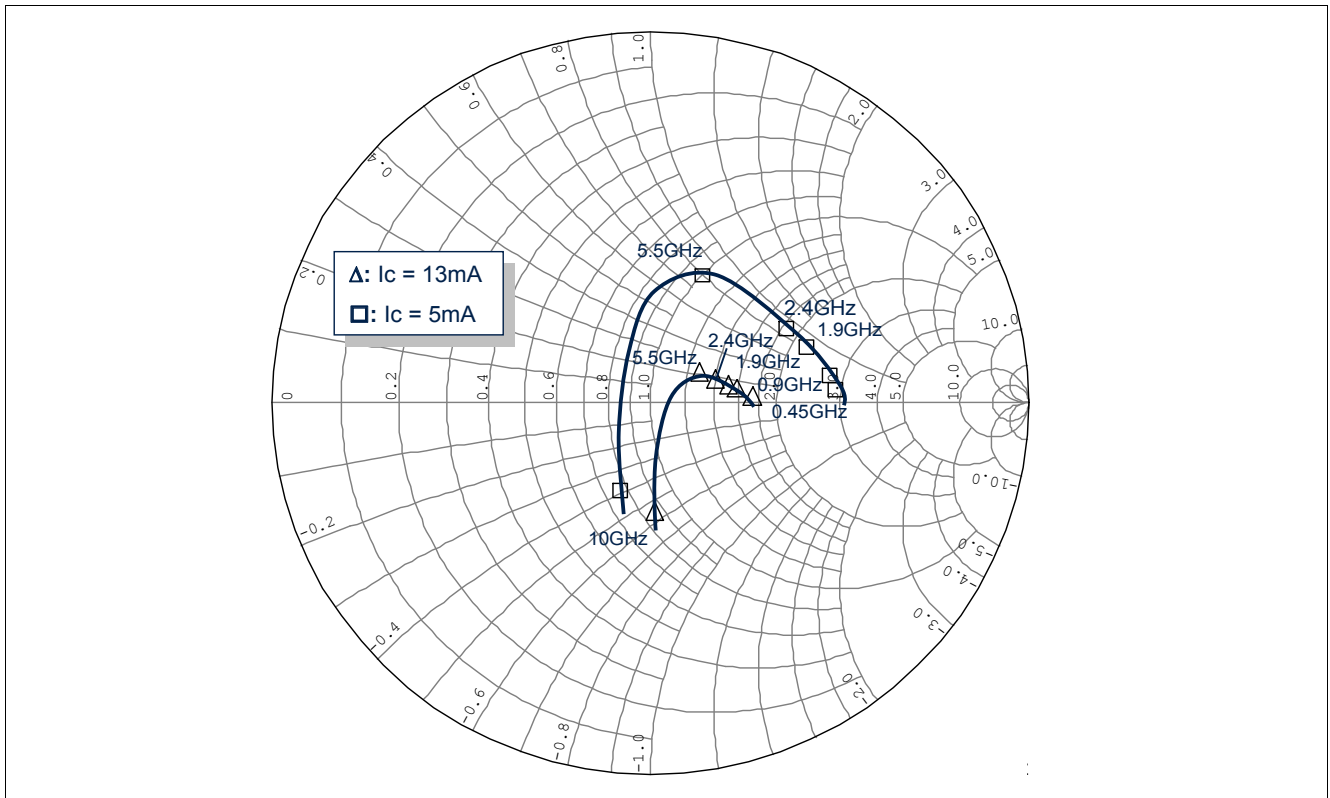

Figure 11 Source Impedance Z_{opt} for NF_{min} vs. Frequency, $V_{CE} = 3\text{ V}$, $I_C = 5\text{ mA} / 13\text{ mA}$

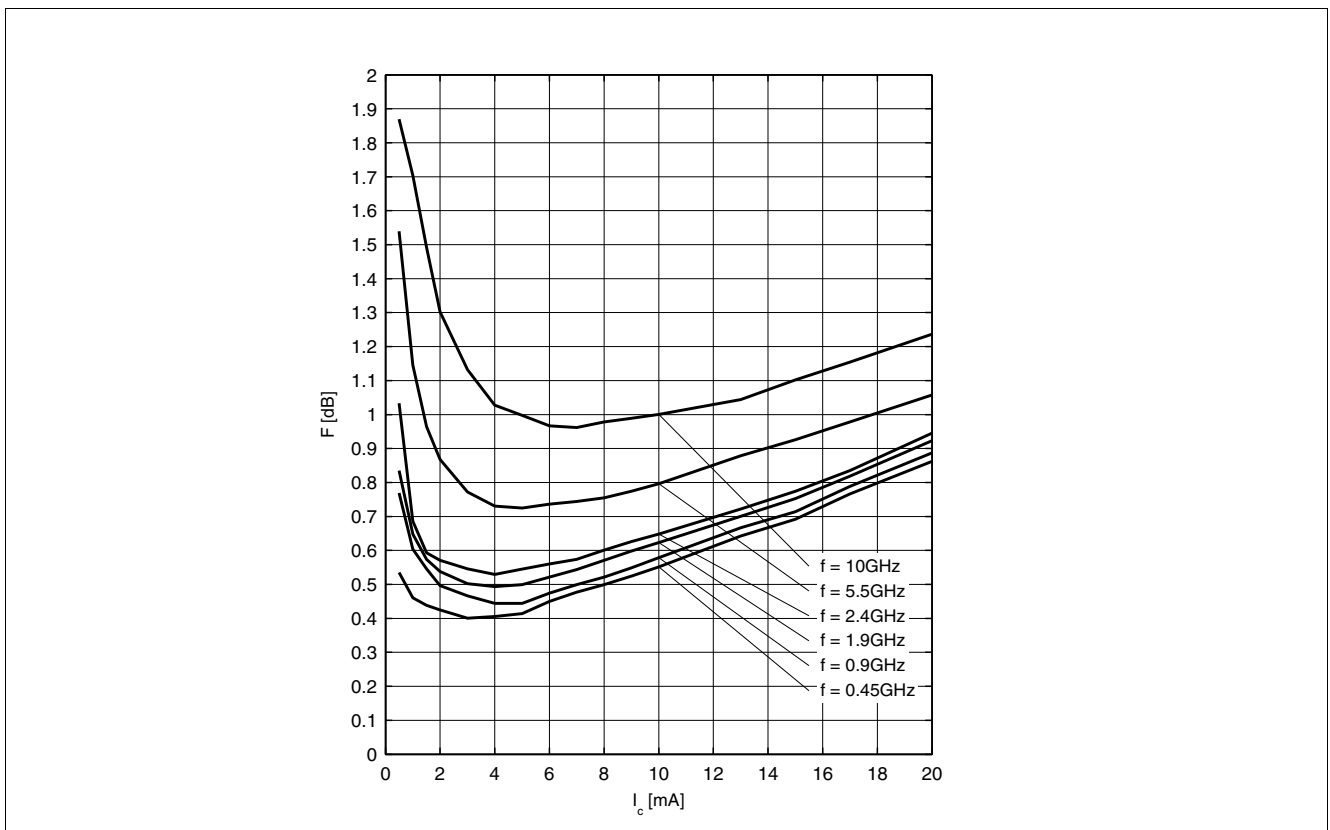

Figure 12 Noise Figure $NF_{min} = f(I_C)$, $V_{CE} = 3\text{ V}$, $Z_S = Z_{opt}$

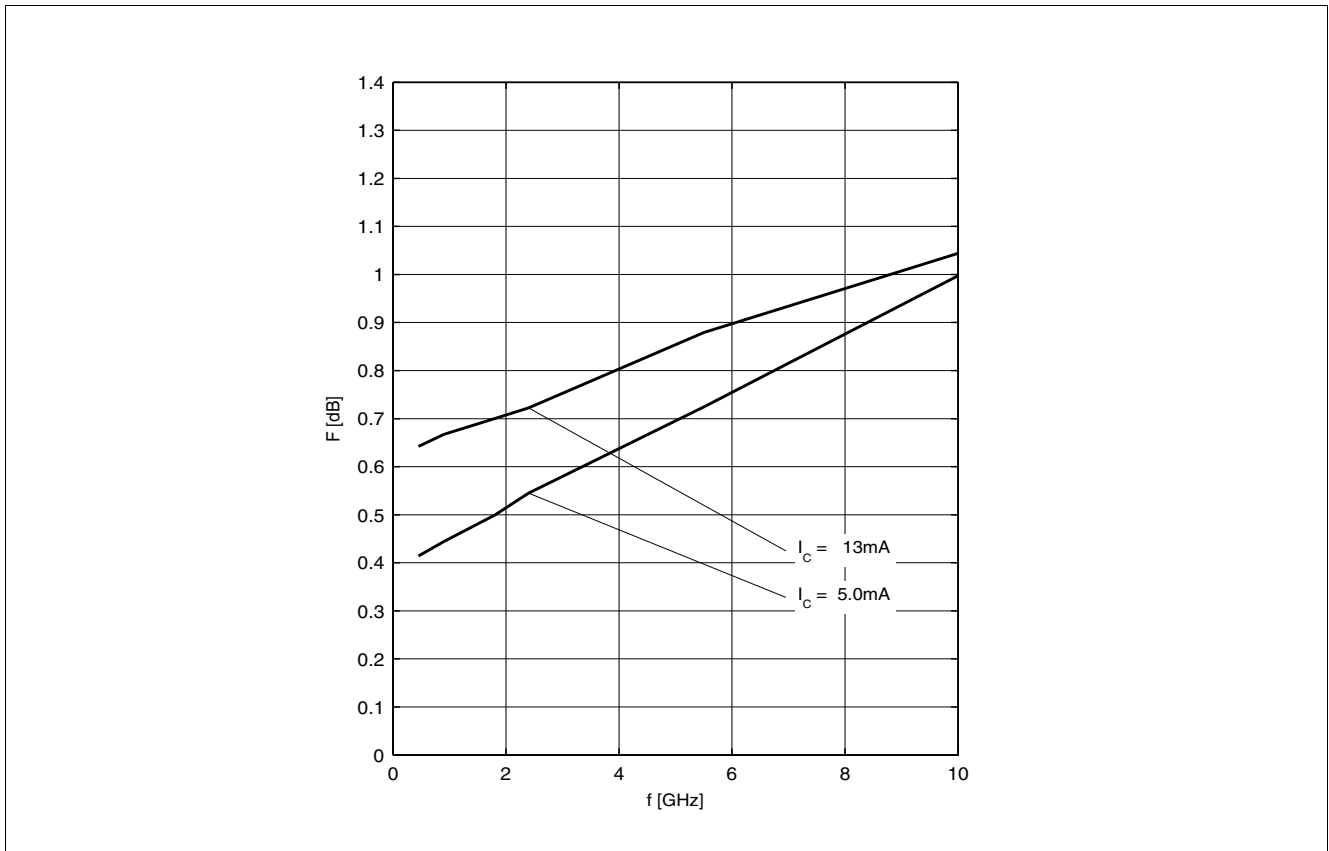

Figure 13 Noise Figure $NF_{\min} = f(\text{freq})$, $V_{CE} = 3\text{ V}$, $Z_S = Z_{\text{opt}}$

Note: The curves shown in this chapter have been generated using typical devices but shall not be considered as a guarantee that all devices have identical characteristic curves.

6 Simulation Data

For SPICE-model as well as for S-parameters including noise parameters please refer to our internet website: www.infineon.com/rf.models . Please consult our website and download the latest versions before actually starting your design.

The simulation data have been generated and verified using typical devices. The BFP720F nonlinear SPICE-model reflects the typical DC- and RF-device performance with high accuracy.

7 Package Information

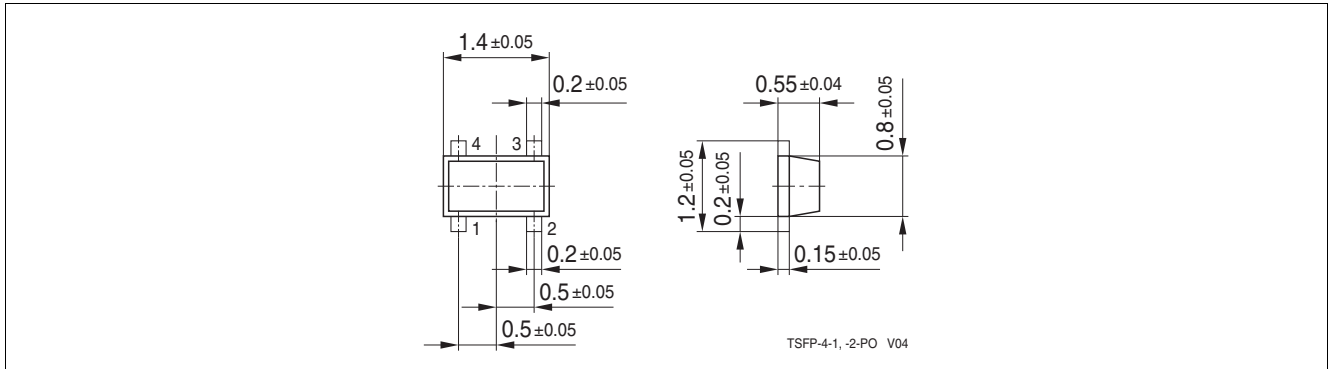

Figure 14 Package Outline TSFP-4(top / side view)

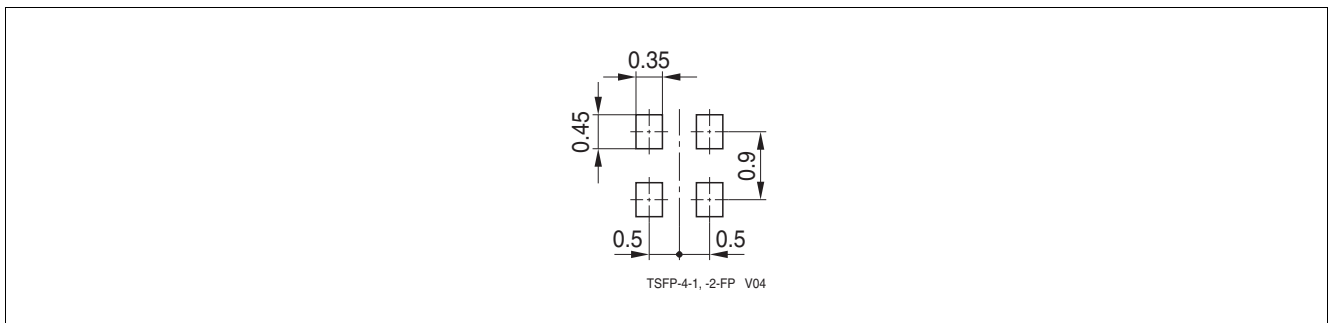

Figure 15 Footprint

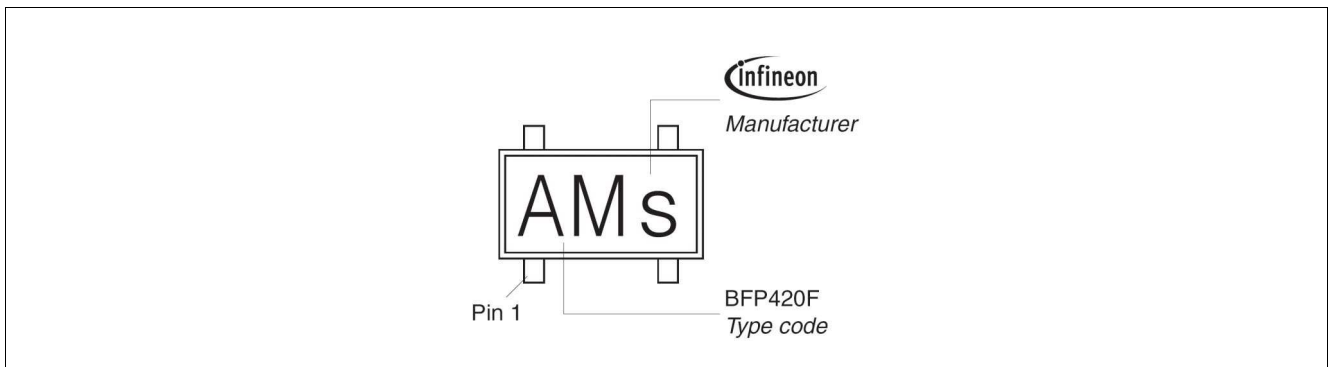

Figure 16 Marking Example (Marking BFP720F: R9s)

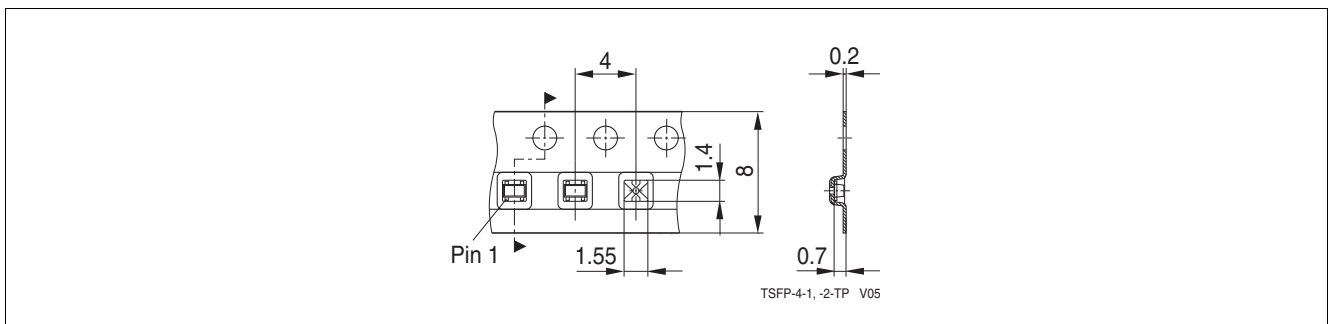

Figure 17 Tape Dimensions

www.infineon.com

Published by Infineon Technologies AG