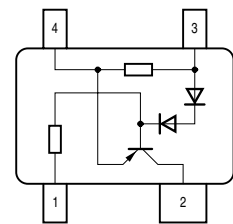
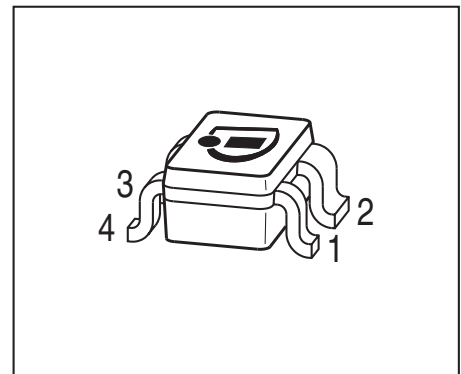

Active Bias Controller
Characteristics

- Supplies stable bias current even at low battery voltage and extreme ambient temperature variation
- Low voltage drop of 0.7V

Application notes

- Stabilizing bias current of NPN transistors and FET's from less than 0.2mA up to more than 200mA
- Ideal supplement for Sieget and other transistors
- also usable as current source up to 5mA

EHA07188

- Pb-free (RoHS compliant) package¹⁾
- Qualified according AEC Q101



Type	Marking	Pin Configuration				Package
BCR400W	W4s	1=GND/ E _{NPN}	2=Contr/ B _{NPN}	3V _S	4=Rext/ C _{NPN}	SOT343

(E_{NPN}, B_{NPN}, C_{NPN} are electrodes of a stabilized NPN transistor)

Maximum Ratings

Parameter	Symbol	Value	Unit
Source voltage	V _S	18	V
Control current	I _{Contr.}	10	mA
Control voltage	V _{Contr.}	16	V
Reverse voltage between all terminals	V _R	0.5	
Total power dissipation, T _S = 117 °C	P _{tot}	330	mW
Junction temperature	T _j	150	°C
Storage temperature	T _{stg}	-65 ... 150	

Thermal Resistance

Junction - soldering point ²⁾	R _{thJS}	≤ 100	K/W
--	-------------------	-------	-----

¹Pb-containing package may be available upon special request

²For calculation of R_{thJA} please refer to Application Note Thermal Resistance

Electrical Characteristics at $T_A=25^\circ\text{C}$, unless otherwise specified

Parameter	Symbol	Values			Unit
		min.	typ.	max.	
DC Characteristics					
Additional current consumption $V_S = 3\text{ V}$	I_0	-	20	40	μA
Lowest stabilizing current $V_S = 3\text{ V}$	I_{min}	-	0.1	-	mA
DC Characteristics with stabilized NPN-Transistors					
Lowest sufficient battery voltage $I_B (\text{NPN}) < 0.5\text{mA}$	$V_{S\text{min}}$	-	1.6	-	V
Voltage drop ($V_S - V_{CE}$) $I_C = 25\text{ mA}$	V_{drop}	-	0.65	-	
Change of I_C versus h_{FE} $h_{FE} = 50$	$\Delta I_C / I_C$	-	0.08	-	$\Delta h_{FE} / h_{FE}$
Change of I_C versus V_S $V_S = 3\text{ V}$	$\Delta I_C / I_C$	-	0.15	-	$\Delta V_S / V_S$
Change of I_C versus T_A	$\Delta I_C / I_C$	-	0.2	-	$\% / \text{K}$

Collector current $I_C = f(h_{FE})$

I_C and h_{FE} refer to stabilized NPN Transistor

Parameter $R_{ext.}$ (Ω)

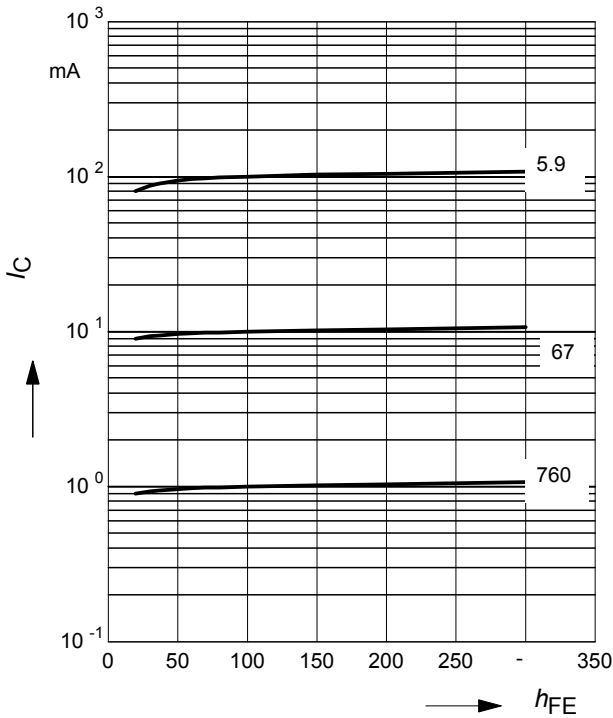

Collector Current $I_C = f(V_S)$

of stabilized NPN Transistor

Parameter $R_{ext.}$ (Ω)

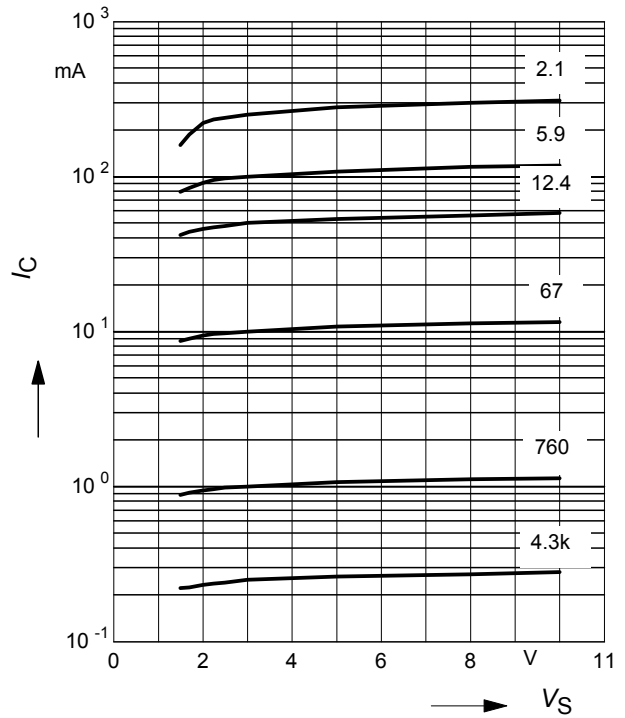

Voltage drop $V_{drop} = f(I_C)$

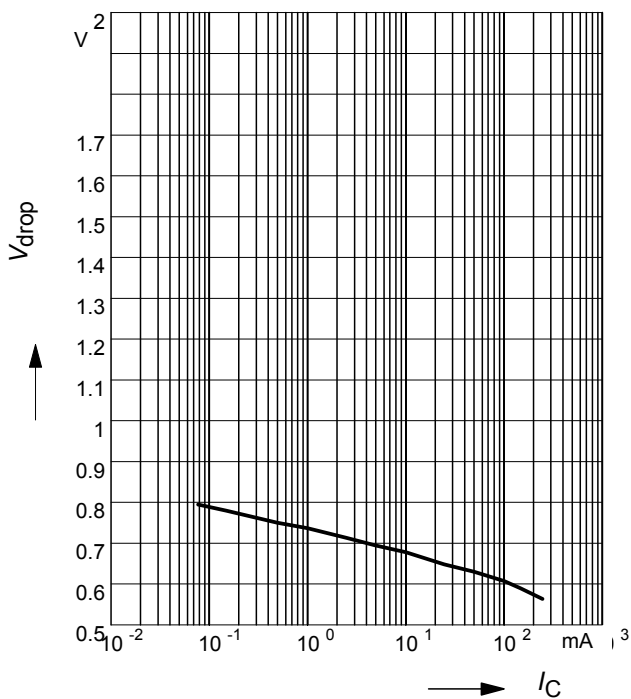

Collector current $I_C = f(R_{ext.})$

of stabilized NPN Transistor

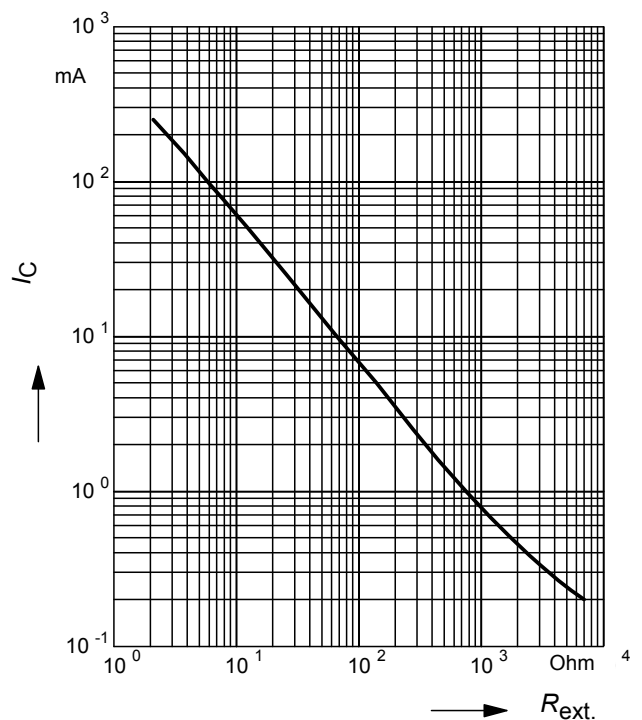

Collector current $T_A = f(I_C)$
of stabilized NPN Transistor

Parameter: $R_{ext.} (\Omega)$

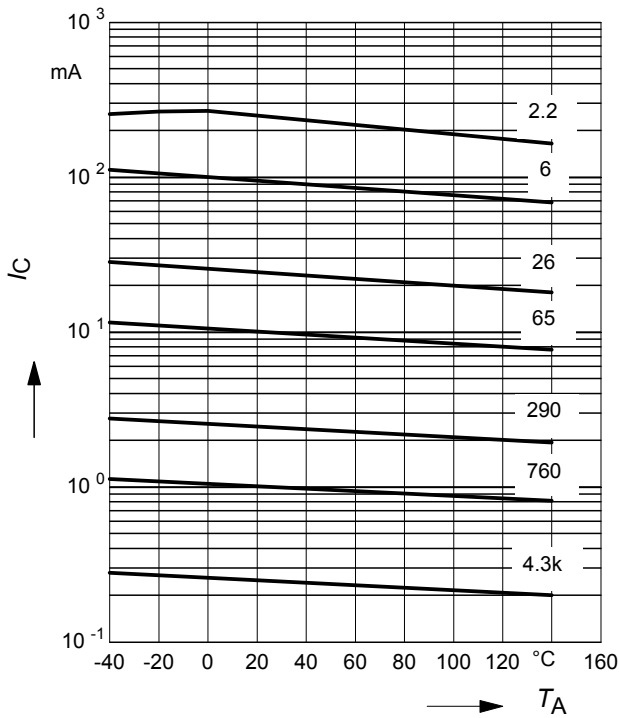

Control current $I = f(R_{ext.})$
in current source application

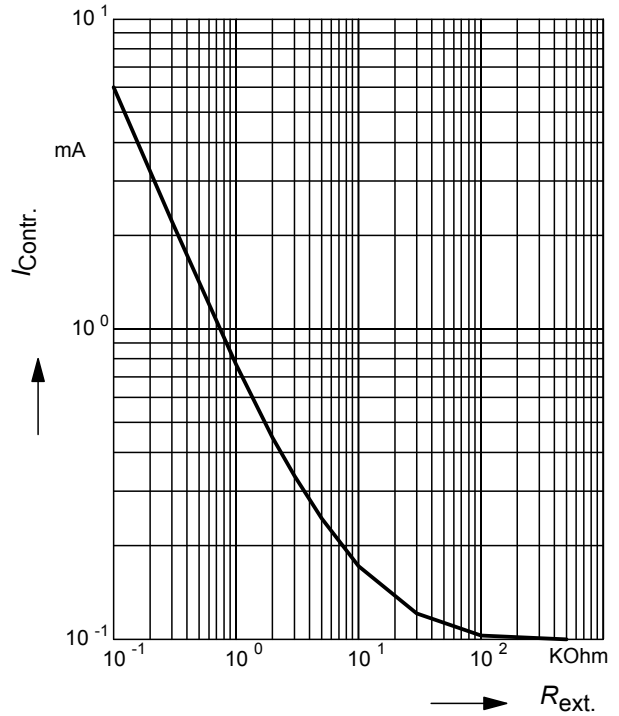

Control current $I = f(T_A)$
in current source application

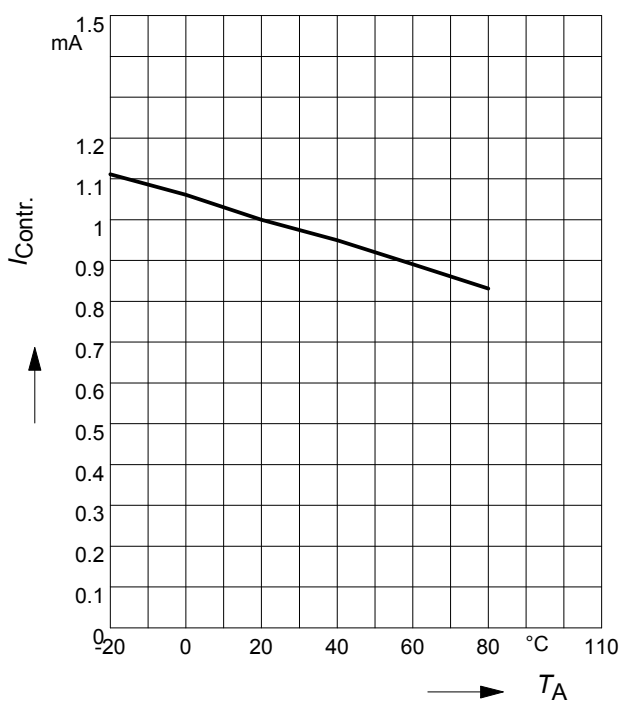

Control current $I = f(V_S)$
in current source application

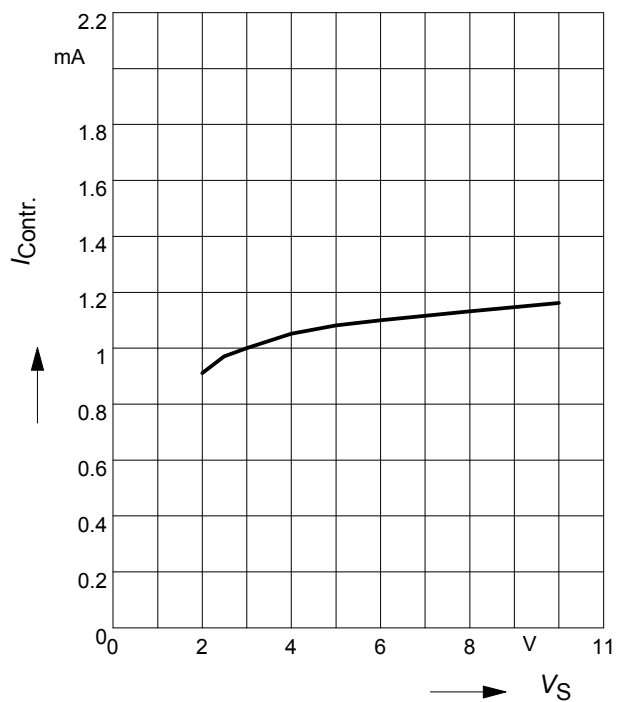

Total power dissipation $P_{tot} = f(T_S)$

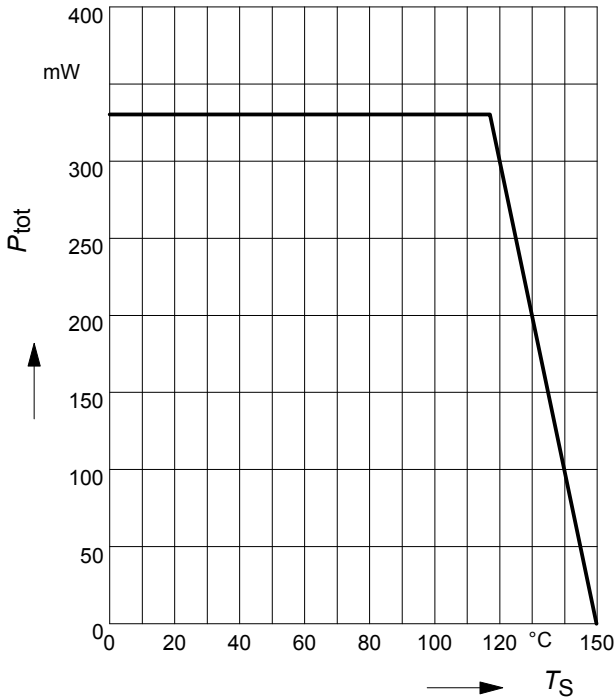

Note that up to $T_S=115^{\circ}\text{C}$ it is not possible to exceed P_{tot} respecting the maximum ratings of V_S and I_{Contr} .
The collector or drain current (respectively) of the stabilized RF transistor does not affect BCR 400 directly, as it provides just the base current.

Typical application for GaAs FET with active bias controller

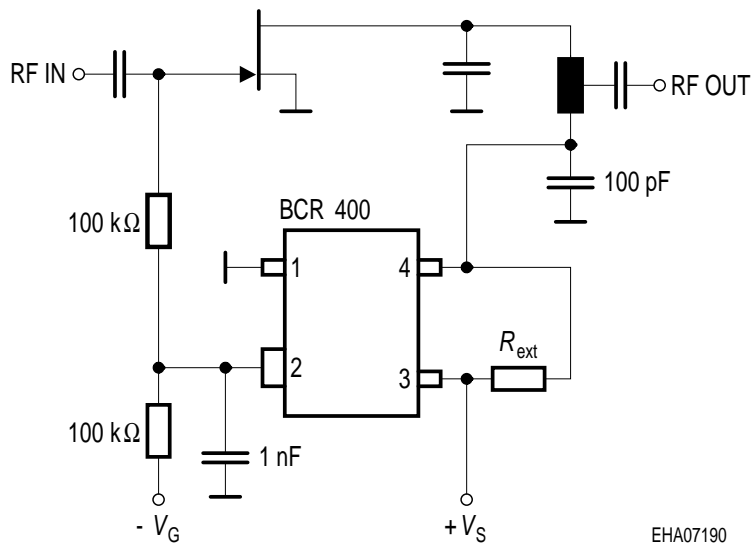

EHA07190

RF transistor controlled by BCR400

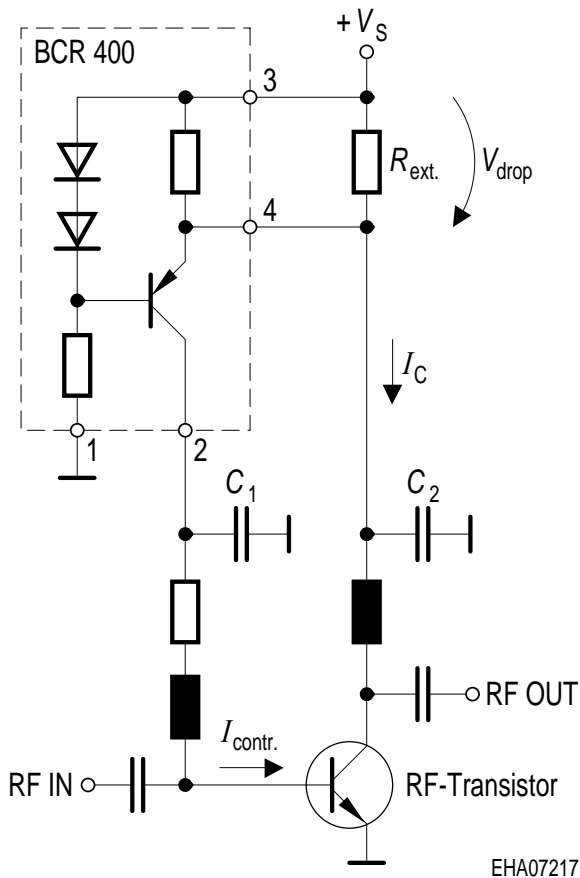

Be aware that BCR400 stabilized bias current of transistors in an active control loop

In order to avoid loop oscillation (hunting), time constants must be chosen adequately, i.e. $C1 \geq 10 \times C2$

EHA07217

RX/TX antenna switch, compatible to control logic and working at wide battery voltage range

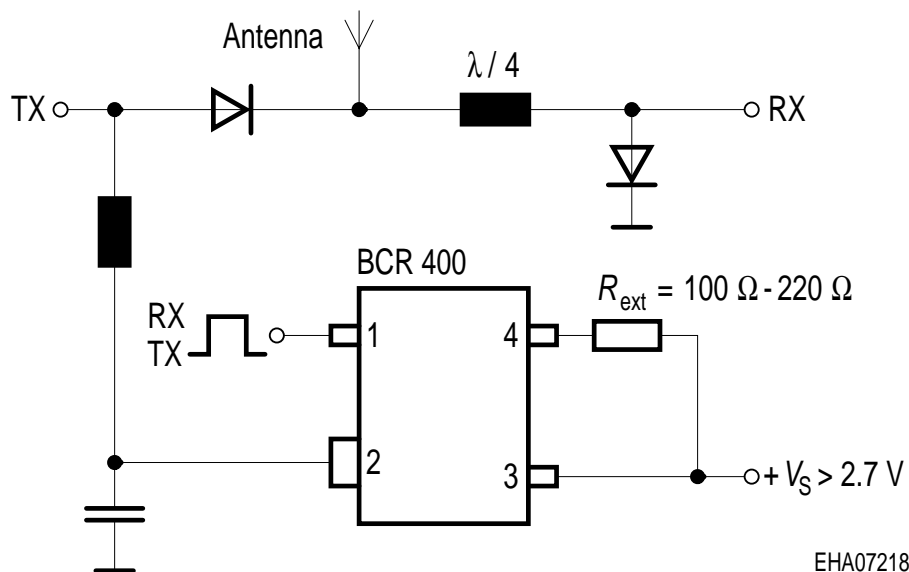

EHA07218

Low voltage reference

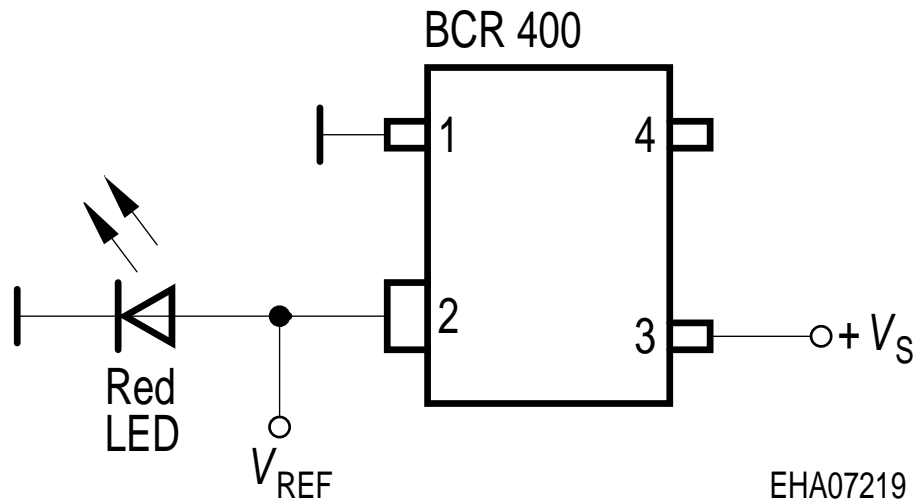

Precision timer with BCR400 providing constant charge current

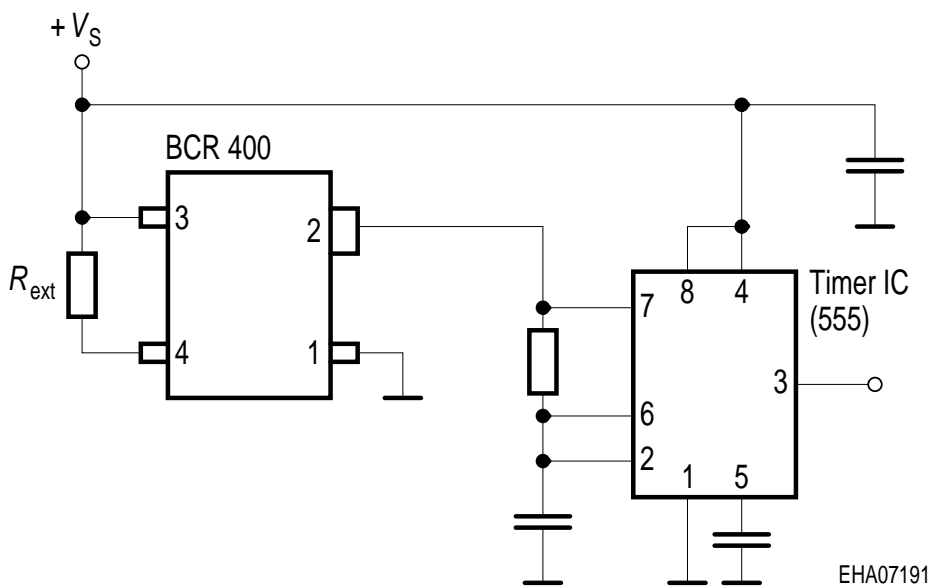

Package Outline

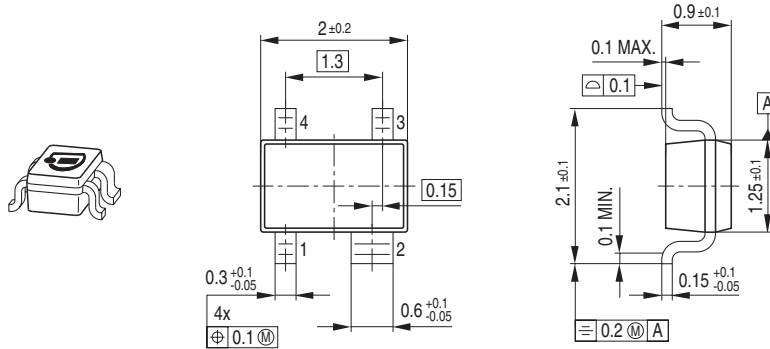

Foot Print

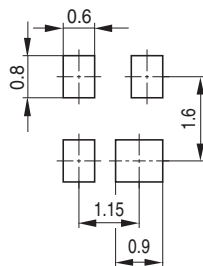

Marking Layout (Example)

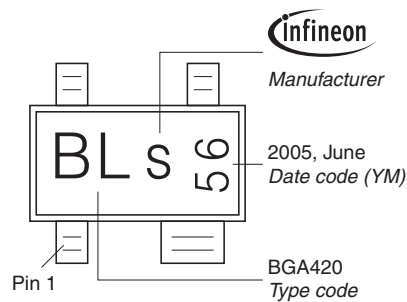

Standard Packing

Reel \varnothing 180 mm = 3.000 Pieces/Reel
 Reel \varnothing 330 mm = 10.000 Pieces/Reel

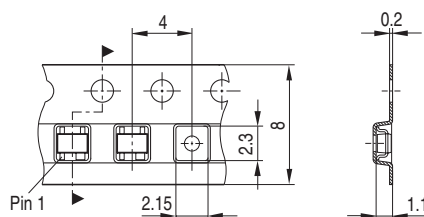

Published by
Infineon Technologies AG
81726 München, Germany
© Infineon Technologies AG 2007.
All Rights Reserved.

Attention please!

The information given in this data sheet shall in no event be regarded as a guarantee of conditions or characteristics ("Beschaffenheitsgarantie"). With respect to any examples or hints given herein, any typical values stated herein and/or any information regarding the application of the device, Infineon Technologies hereby disclaims any and all warranties and liabilities of any kind, including without limitation warranties of non-infringement of intellectual property rights of any third party.

Information

For further information on technology, delivery terms and conditions and prices please contact your nearest Infineon Technologies Office (www.infineon.com).

Warnings

Due to technical requirements components may contain dangerous substances. For information on the types in question please contact your nearest Infineon Technologies Office.

Infineon Technologies Components may only be used in life-support devices or systems with the express written approval of Infineon Technologies, if a failure of such components can reasonably be expected to cause the failure of that life-support device or system, or to affect the safety or effectiveness of that device or system.

Life support devices or systems are intended to be implanted in the human body, or to support and/or maintain and sustain and/or protect human life. If they fail, it is reasonable to assume that the health of the user or other persons may be endangered.