

## Features

- Micro power design
- 2.4 V to 5.5 V battery operation
- High sensitivity and high stability of the magnetic switching points
- High resistance to mechanical stress
- Digital output signal
- Switching for both poles of a magnet (omnipolar)
- Not suitable for automotive application

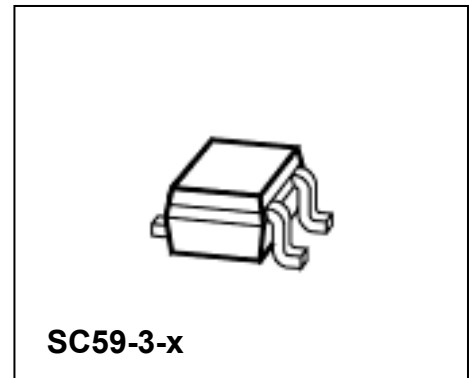

## Functional Description

The TLE4913 is an Integrated Hall-Effect Sensor designed specifically to meet the requirements of low-power devices. e.g. as an On/Off switch in Cellular Flip-Phones, with battery operating voltages of 2.4V – 5.5V.

Precise magnetic switching points and high temperature stability are achieved through the unique design of the internal circuit.

An onboard clock scheme is used to reduce the average operating current of the IC.

During the operate phase the IC compares the actual magnetic field detected with the internally compensated switching points. The output Q is switched at the end of each operating phase.

During the Stand-by phase the output stage is latched and the current consumption of the device reduced to some  $\mu\text{A}$ .

The IC switching behaviour is Omnipolar, i.e. it can be switched on with either the North or South pole of a magnet.

Type	Marking	Ordering Code	Package
TLE 4913	13s 013	Q62705K 619	SC 59-3-x

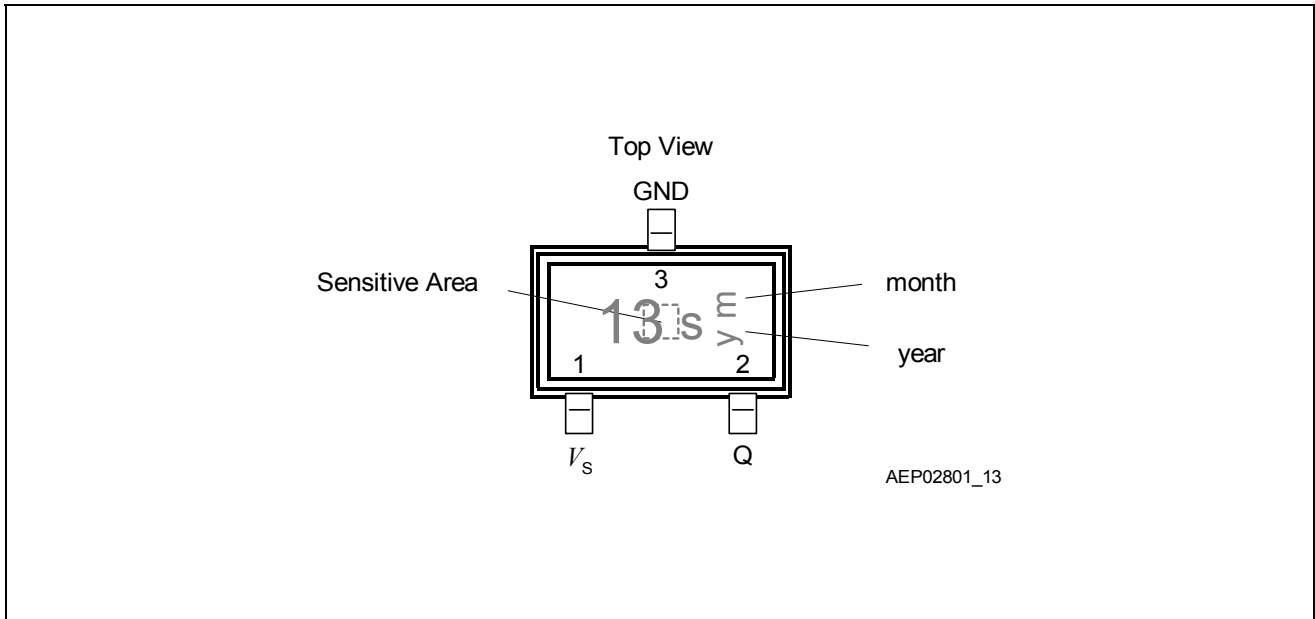

**Figure 1 Pin Configuration (top view)**

### Pin Definitions and Functions

Pin	Symbol	Function
1	$V_s$	Supply Voltage
2	$Q$	Open Drain Input
3	$Gnd$	Ground

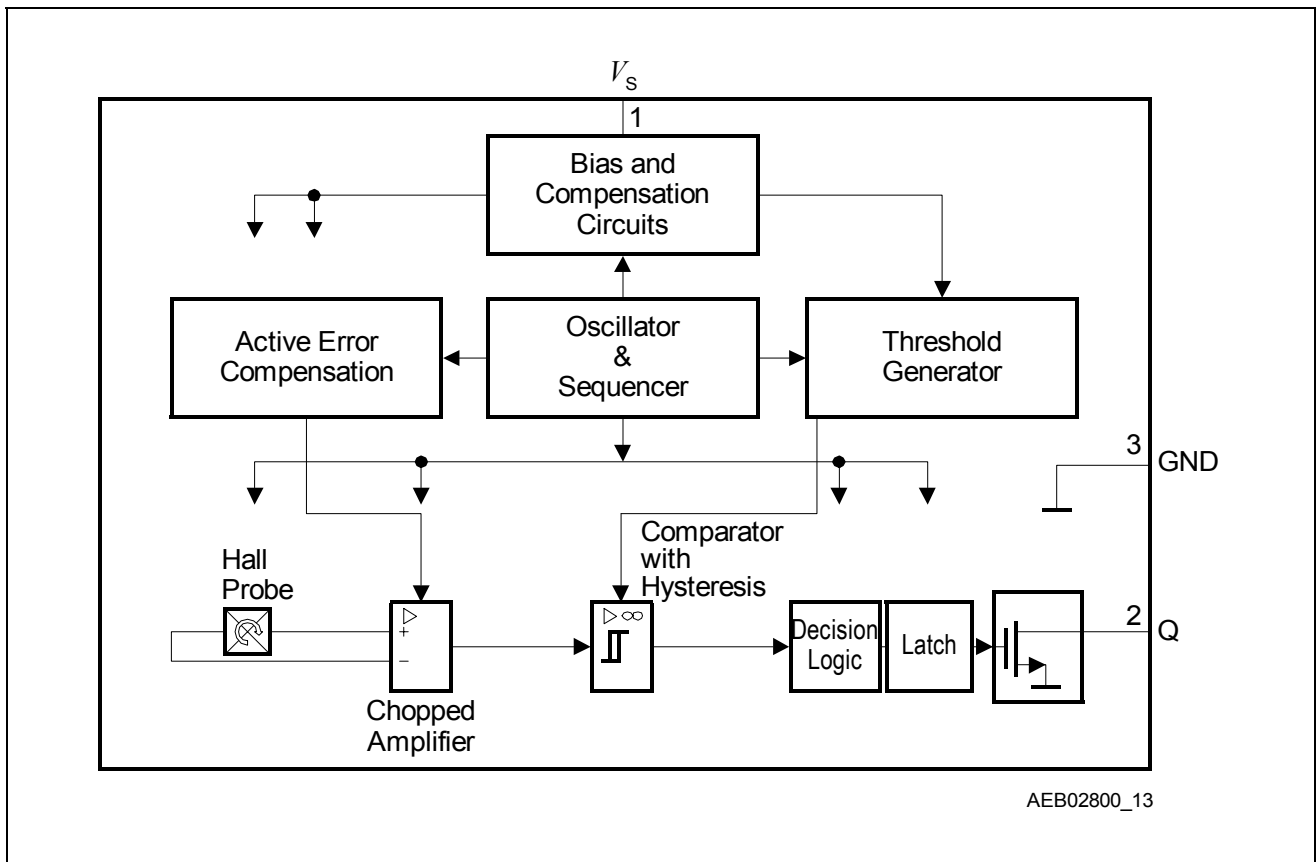

**Figure 2 Block Diagram**

### Circuit Description

The Low Power Hall IC Switch comprises a Hall probe, bias generator, compensation circuits, oscillator, output latch and an n-channel open drain output transistor.

The bias generator provides currents for the Hall probe and the active circuits. Compensation circuits stabilize the temperature behavior and reduce technology variations.

The Active Error Compensation rejects offsets in signal stages and the influence of mechanical stress to the Hall probe caused by molding and soldering processes and other thermal stresses in the package. This chopper technique together with the threshold generator and the comparator ensures high accurate magnetic switching points.

Very low power consumption is achieved with a timing scheme controlled by an oscillator and a sequencer. This circuitry activates the sensor for 50  $\mu\text{s}$  (typical operating time) sets the output state after sequential questioning of the switch points and latches it with the beginning of the following standby phase (max. 200 ms). In the standby phase the average current is reduced to typical 4  $\mu\text{A}$ . Because of the long standby time compared to the operating time the overall averaged current is only slightly higher than the standby current.

The output transistor can sink up to 1 mA with a maximal saturation voltage  $V_{\text{QSAT}}$ .

## Absolute Maximum Ratings

Parameter	Symbol	Limit Values		Unit	Notes
		min.	max.		
Supply Voltage	$V_S$	- 0.3	5.5	V	
Supply Current	$I_S$	- 1	2.5	mA	
Output Voltage	$V_Q$	- 0.3	5.5	V	
Output Current	$I_Q$	- 1	2	mA	
Junction temperature	$T_j$	- 40	150	°C	
Storage temperature	$T_S$	- 40	150	°C	
Magnetic Flux Density	$B$	-	unlimited	mT	
Thermal Resistance P-SC59-3-x	$R_{th JA}$	-	35	K/W	

*Note: Stresses above those listed here may cause permanent damage to the device. Exposure to absolute maximum rating conditions for extended periods may affect device reliability.*

## ESD Protection

Human Body Model (HBM) tests according to:  
EOS/ESD Association Standard S5.1-1993 and Mil. Std. 883D method 3015.7

Parameter	Symbol	Limit Values		Unit	Notes
		Min.	Max.		
ESD Voltage	$V_{ESD}$		± 4	kV	$R = 1.5 \text{ k}\Omega$ , $C = 100 \text{ pF}$ ; $T = 25 \text{ }^\circ\text{C}$

## Operating Range

Parameter	Symbol	Limit Values			Unit	Notes
		Min.	typ.	max.		
Supply voltage	$V_S$	2.4	2.7	5.5	V	<sup>1)</sup>
Output voltage	$V_Q$	- 0.3	2.7	5.5	V	
Ambient Temperature	$T_A$	- 40	25	85	°C	

<sup>1)</sup> A Ceramic Bypass Capacitor of 100 nF at  $V_S$  to GND is highly recommended.

## AC/DC Characteristics

Parameter	Symbol	Limit Values			Unit	Notes
		Min.	typ.	Max.		
Averaged Supply Current	$I_{SAVG}$	1	4	20	µA	
Averaged Supply Current during Operating Time	$I_{SOPAVG}$	0.5	1.1	2.5	mA	
Transient Peak Supply Current during Operating Time	$I_{SOPT}$	-	-	2.5	mA	$t < 100$ ns
Supply Current during Standby Time	$I_{SSTB}$	1	3.5	20	µA	
Output Saturation Voltage	$V_{QSAT}$	-	0.13	0.4	V	$I_Q = 1$ mA
Output Leakage Current	$I_{QLEAK}$	-	0.01	1	µA	
Output Rise Time	$t_r$	-	0.5	1	µs	$R_L = 2.7$ kΩ; $C_L = 10$ pF
Output Fall Time	$t_f$	-	0.1	1	µs	$R_L = 2.7$ kΩ; $C_L = 10$ pF
Operating Time	$t_{op}$	15	50	93 <sup>1) 2)</sup>	µs	
Standby Time	$t_{stb}$	-	130	240 <sup>3)</sup>	ms	
Duty Cycle	$t_{op} / t_{stb}$	-	0.039	-	%	
Start-up Time of IC	$t_{stu}$	-	6	12	µs	<sup>4)</sup>

<sup>1)</sup> for  $V_S=3.5$ V the max. Operating Time  $t_{op\ max} = 85$ µs

<sup>2)</sup> includes the Start-up Time  $t_{stu}$

<sup>3)</sup> for  $V_S=3.5$ V the max. Standby Time  $t_{stb\ max} = 220$ ms

<sup>4)</sup> initial power on time.  $V_S$  must be applied in this time ( typ. 6µs to max. 12µs ) to get already a valid output state after the first operating phase (typ. 56µs). For rise times of  $V_S > 12$ µs, the output state is valid after the second operating phase (includes one standby phase), e.g. happens only when the battery in flip phones is changed.

## Magnetic Characteristics

Parameter	Symbol	Limit Values			Unit	Notes
		min.	typ.	max.		
Operate Points (Output on)	B <sub>OPS</sub>	2	3.5	5	mT	1)
	B <sub>OPN</sub>	- 5	- 3.5	- 2	mT	
Release Points (Output off)	B <sub>RPS</sub>	1,2	2.7	4.2	mT	1)
	B <sub>RPN</sub>	- 4.2	- 2.6	- 1,2	mT	
Hysteresis	B <sub>HYS</sub>	0.2	0.8	1,6	mT	

<sup>1)</sup> Positive magnetic fields are related to the approach of a magnetic south pole to the branded side of package

*Note: The listed AC/DC and magnetic characteristics are ensured over the operating range of the integrated circuit. Typical characteristics specify mean values expected over the production spread. If not other specified, typical characteristics apply at  $T_j = 25\text{ °C}$  and  $V_S = 2.7\text{ V}$*

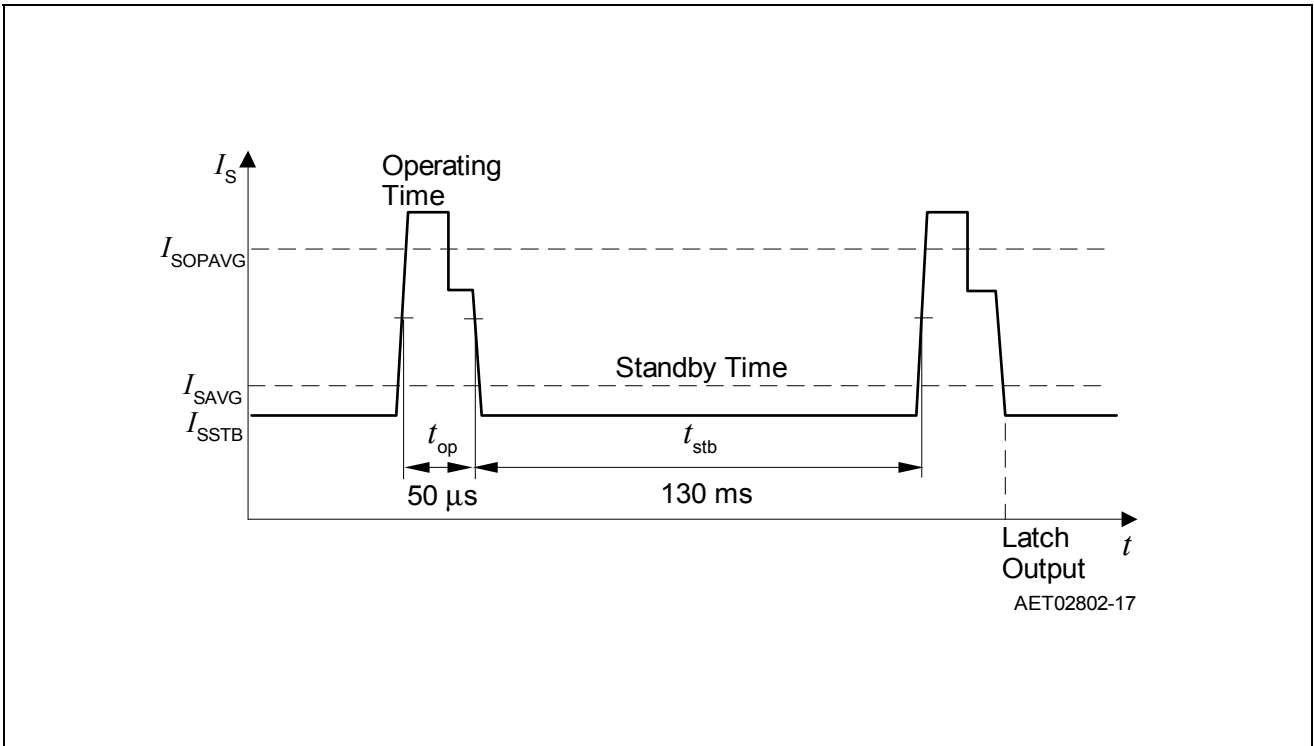

Figure 3 Timing Diagram

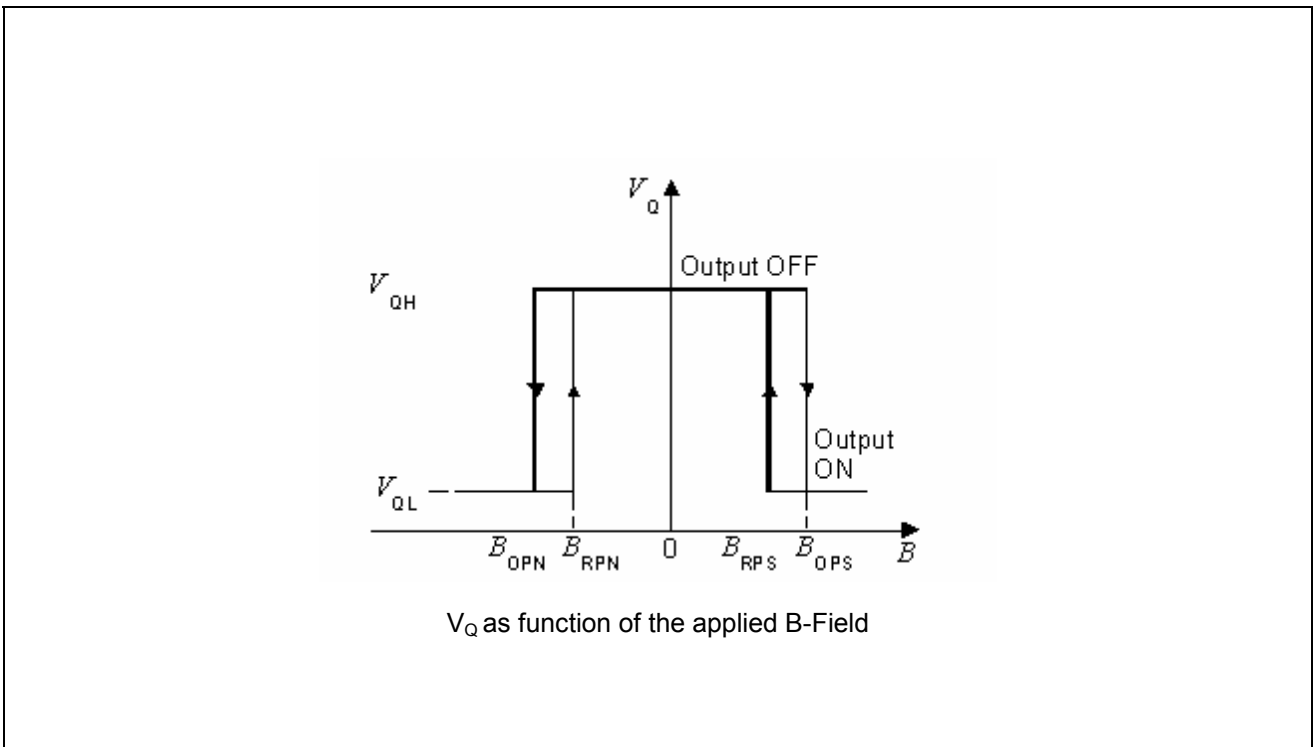
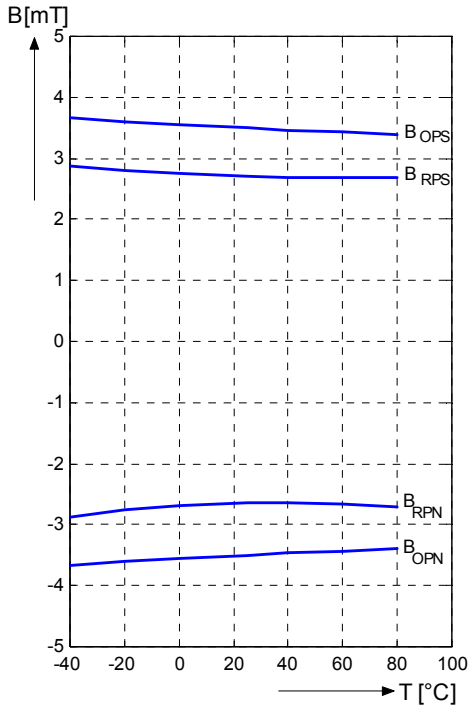

Figure 4 Output – Signal TLE 4913

All curves reflect typical values at the given parameters for  $T_A$  in  $^{\circ}\text{C}$  and  $V_S$  in V.

**Magnetic Switching Points versus Temperature ( $V_S=2.7\text{V}$ )**



**Magnetic Switching Points versus Supply Voltage  $V_S$  ( $T_A=20^{\circ}\text{C}$ )**

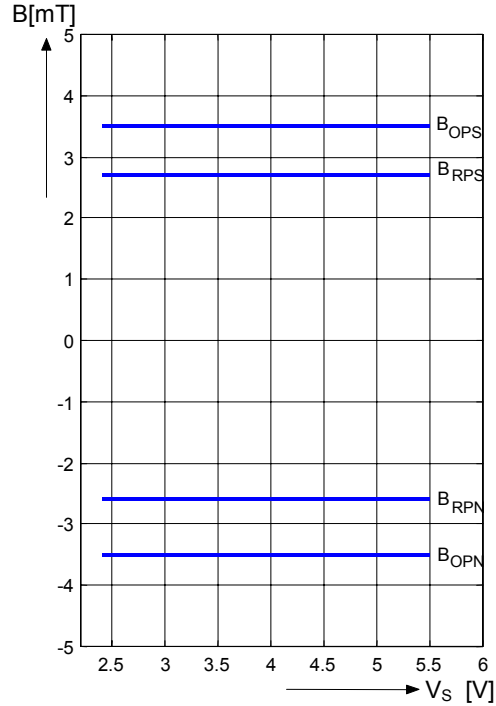

**Supply current  $I_{\text{SOPAVG}}$  during Operating Time versus Temperature ( $V_S=2.7\text{V}$ )**

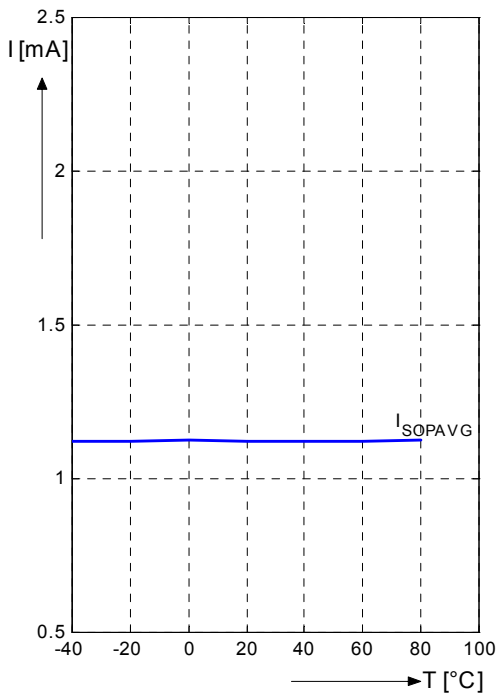

**Supply current  $I_{\text{SOPAVG}}$  during Operating Time versus Supply Voltage  $V_S$  ( $T_A=20^{\circ}\text{C}$ )**

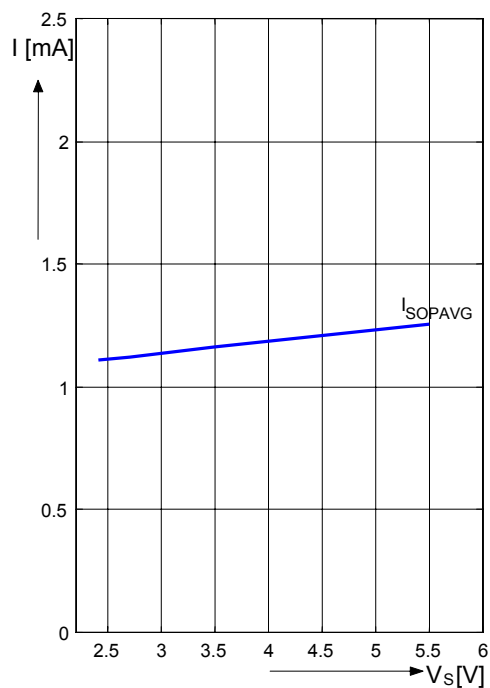



**Supply current  $I_{SSTB}$  during Standby  
Time versus Temperature ( $V_S=2.7V$ )**

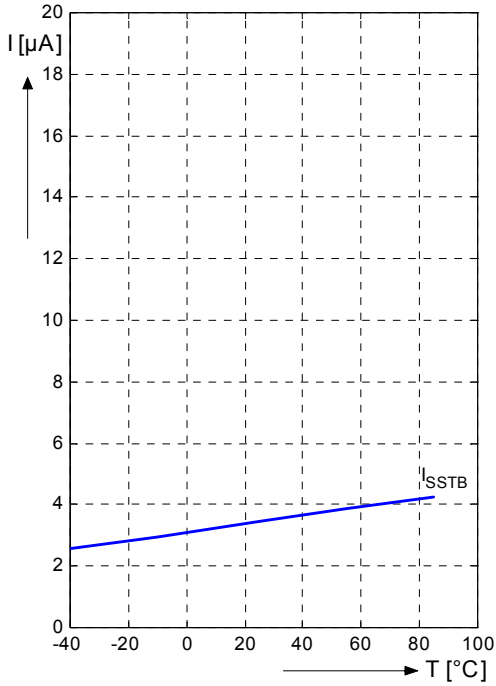

**Supply current  $I_{SSTB}$  during Standby  
Time versus Supply Voltage  $V_S$  ( $T_A=20^\circ C$ )**

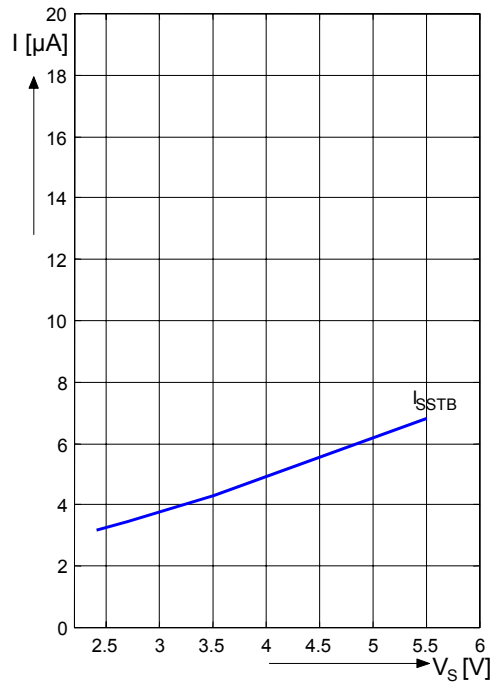

**Output Saturation voltage  $V_{QSAT}$   
versus Temperature ( $I_Q=1mA$ )**

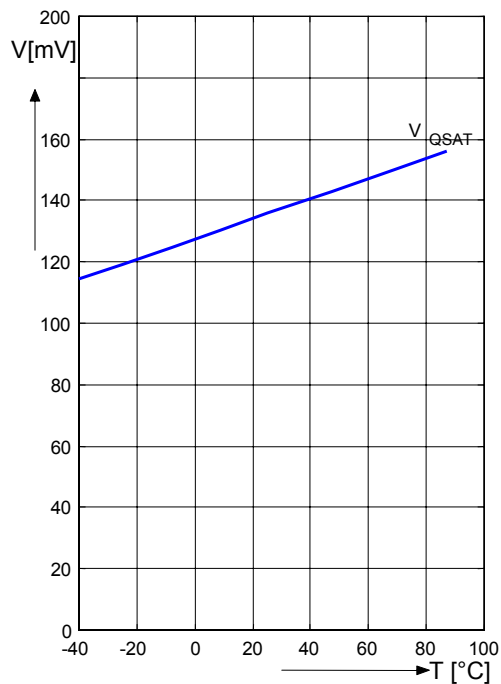

**Standby Time  $t_{stb}$  versus Temperature  
( $V_S = 2.7V$ )**

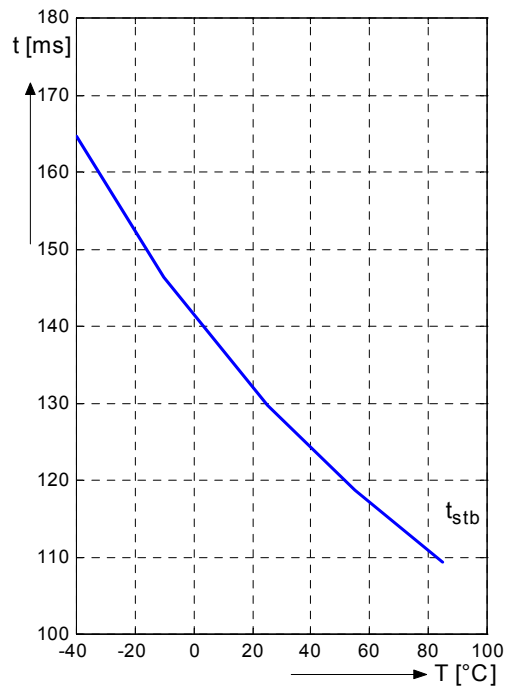

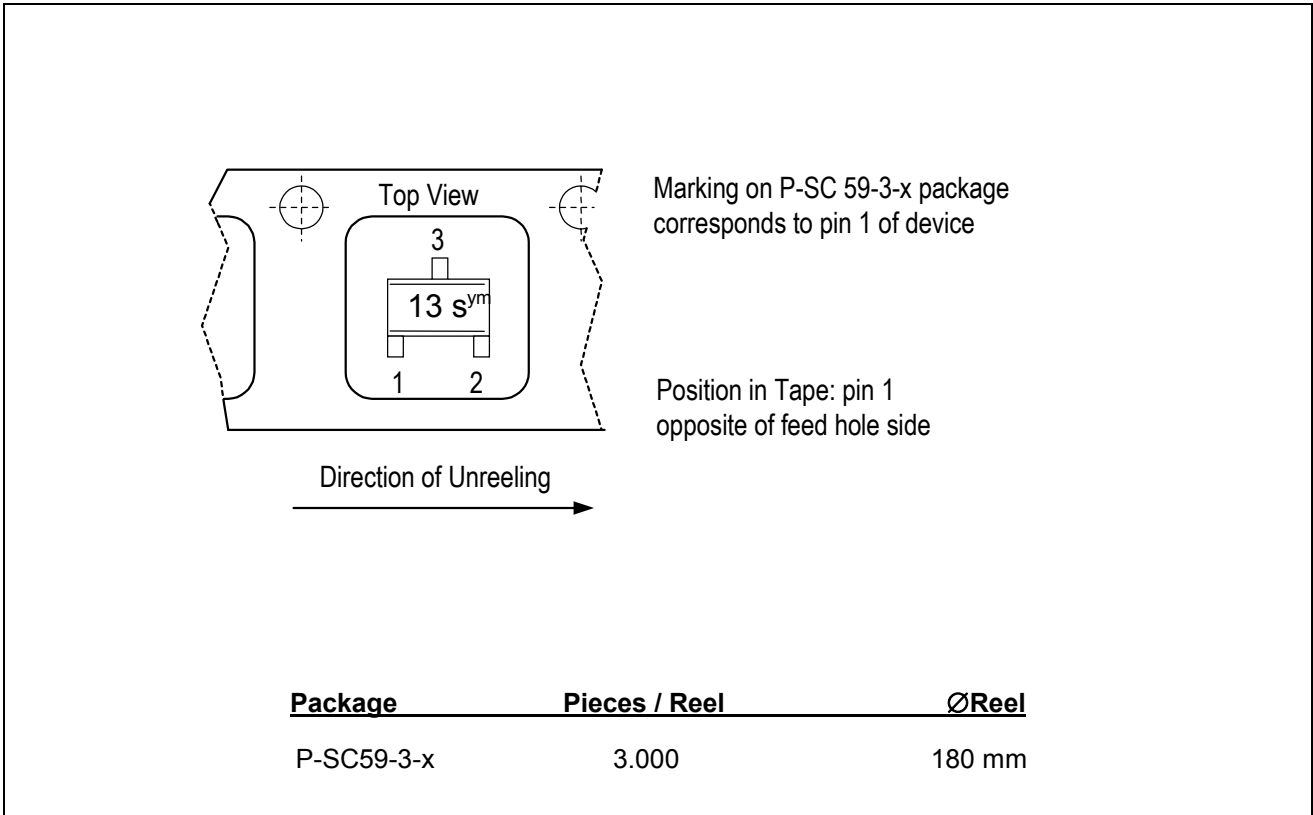

**Figure 5 Marking and Tape Loading Orientation**

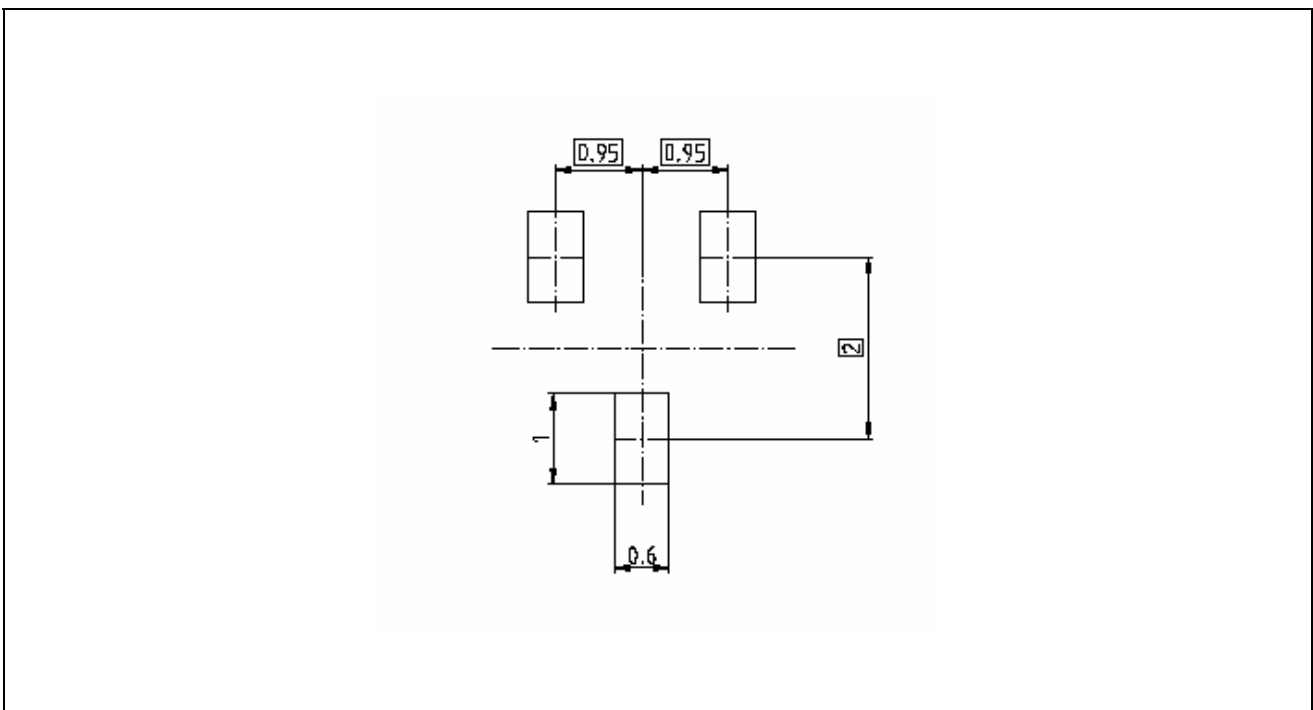

**Figure 6 Foot Print Reflow Soldering**

## Package Dimensions

### P-SC 59-3-x - Package

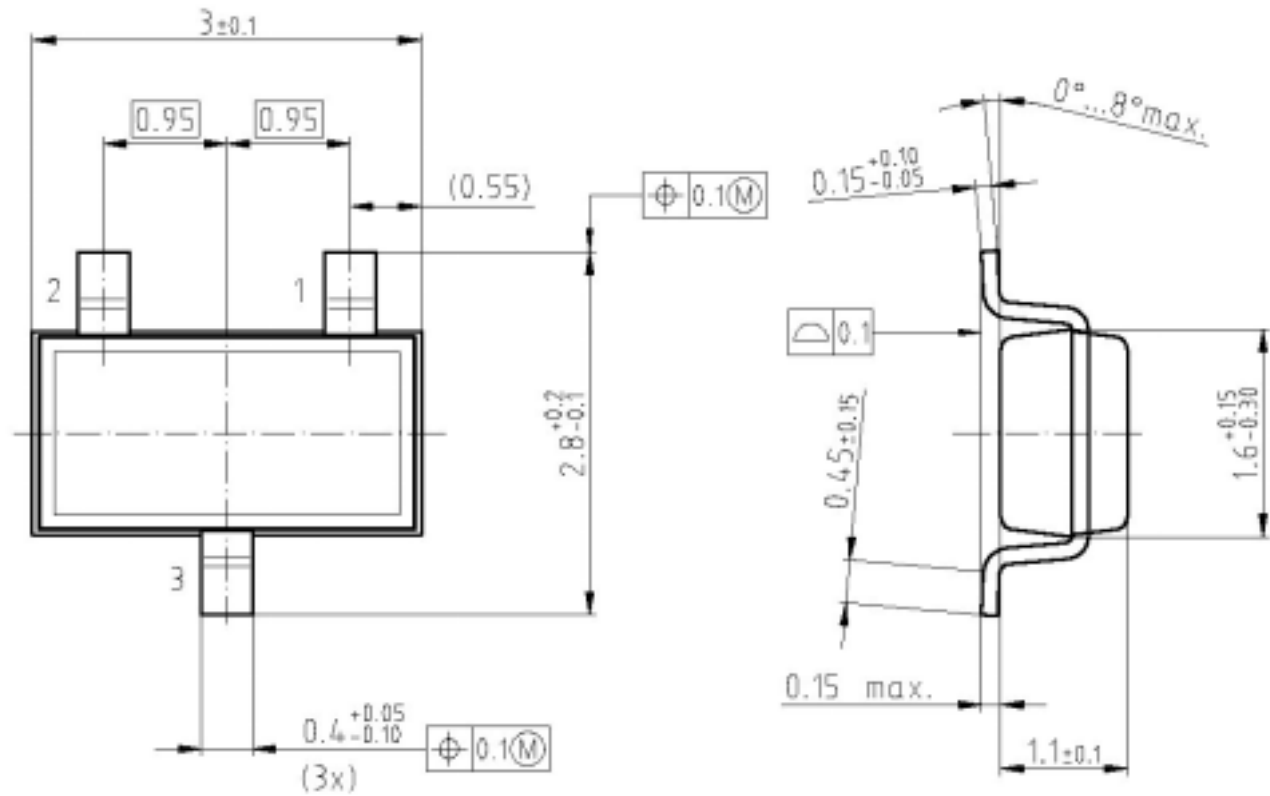

coplanarity : 0.10mm

### Sorts of Packing

Package outlines for tubes, trays etc. are contained in our Data Book "Package Information".

SMD = Surface Mounted Device

<b>TLE4913</b>		<b>V 2.2</b>
<b>Revision History: 2004-03-09</b>		
Previous Version: 2003-07-16		
Page	Subjects (major changes since last revision)	
4	ESD Level adapted to $\pm 4$ kV	

For questions on technology, delivery and prices please contact the Infineon Technologies Offices in Germany or the Infineon Technologies Companies and Representatives worldwide: see our webpage at <http://www.infineon.com>

### **We Listen to Your Comments**

Any information within this document that you feel is wrong, unclear or missing at all? Your feedback will help us to continuously improve the quality of this document. Please send your proposal (including a reference to this document) to:  
**[feedback.sensors@infineon.com](mailto:feedback.sensors@infineon.com)**

Edition 2002-08-22  
 Published by Infineon Technologies AG  
 St.-Martin-Strasse 53  
 D-81541 München  
 © Infineon Technologies AG 2000  
 All Rights Reserved.

### **Attention please!**

The information herein is given to describe certain components and shall not be considered as warranted characteristics. Terms of delivery and rights to technical change reserved.  
 We hereby disclaim any and all warranties, including but not limited to warranties of non-infringement, regarding circuits, descriptions and charts stated herein.  
 Infineon Technologies is an approved CECC manufacturer.

### **Information**

For further information on technology, delivery terms and conditions and prices please contact your nearest Infineon Technologies Office in Germany or our Infineon Technologies Representatives worldwide (see address list).

### **Warnings**

Due to technical requirements components may contain dangerous substances. For information on the types in question please contact your nearest Infineon Technologies Office.  
 Infineon Technologies Components may only be used in life-support devices or systems with the express written approval of Infineon Technologies, if a failure of such components can reasonably be expected to cause the failure of that life-support device or system, or to affect the safety or effectiveness of that device or system. Life support devices or systems are intended to be implanted in the human body, or to support and/or maintain and sustain and/or protect human life. If they fail, it is reasonable to assume that the health of the user or other persons may be endangered.