



# LOW-VOLTAGE OCTAL BUS SWITCH

## IDT74CBTLV3245

### FEATURES:

- Pin-out compatible with standard '245 Logic products
- 5Ω A/B bi-directional switch
- Isolation under power-off conditions
- Over-voltage tolerant
- Latch-up performance exceeds 100mA
- V<sub>CC</sub> = 2.3V - 3.6V, Normal Range
- ESD > 2000V per MIL-STD-883, Method 3015;  
> 200V using machine model (C = 200pF, R = 0)
- Available in QSOP and TSSOP packages

### APPLICATIONS:

- 3.3V High Speed Bus Switching and Bus Isolation

### DESCRIPTION:

The octal bus switch has standard 245 pinouts. The CBTLV3245 is designed for asynchronous communication between data buses. When Output Enable ( $\overline{OE}$ ) is low, the 8-bit bus switch is on and port A is connected to Port B. When  $\overline{OE}$  is high, the switch is off and a high impedance exists between Port A and Port B.

To ensure the high-impedance state during power up or power down,  $\overline{OE}$  should be tied to V<sub>CC</sub> through a pullup resistor.

### FUNCTIONAL BLOCK DIAGRAM

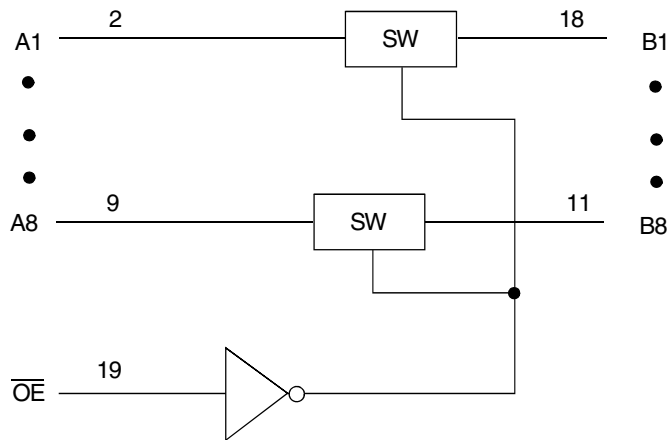

### SIMPLIFIED SCHEMATIC, EACH SWITCH

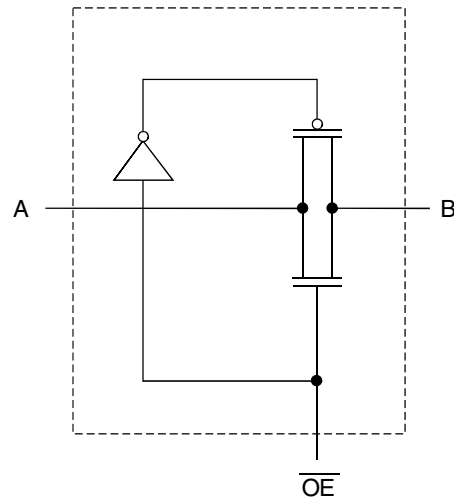

## PIN CONFIGURATION

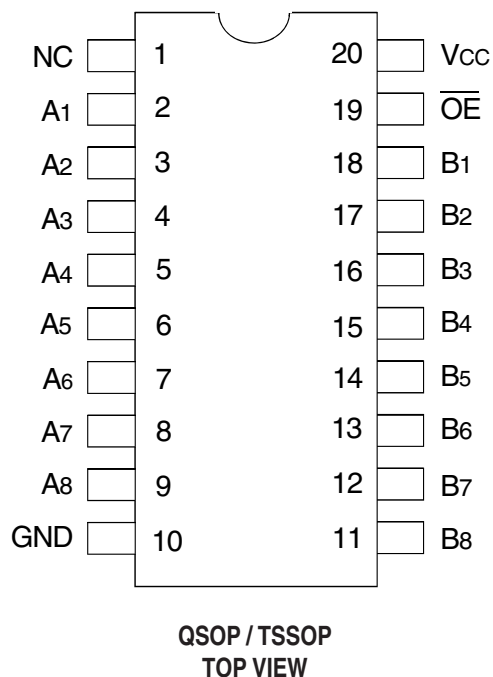

## ABSOLUTE MAXIMUM RATINGS<sup>(1)</sup>

Symbol	Description	Max	Unit
V <sub>CC</sub>	Supply Voltage Range	-0.5 to +4.6	V
V <sub>I</sub>	Input Voltage Range	-0.5 to +4.6	V
	Continuous Channel Current	128	mA
I <sub>IK</sub>	Input Clamp Current, V <sub>I/O</sub> < 0	-50	mA
T <sub>STG</sub>	Storage Temperature	-65 to +150	°C

### NOTE:

1. Stresses greater than those listed under ABSOLUTE MAXIMUM RATINGS may cause permanent damage to the device. This is a stress rating only and functional operation of the device at these or any other conditions above those indicated in the operational sections of this specification is not implied. Exposure to absolute maximum rating conditions for extended periods may affect reliability.

## PIN DESCRIPTION

Pin Names	Description
$\overline{OE}$	Output Enable (Active LOW)
A <sub>x</sub>	Port A Inputs or Outputs
B <sub>x</sub>	Port B Inputs or Outputs

## FUNCTION TABLE<sup>(1)</sup>

Input	Operation
$\overline{OE}$	
L	A Port = B Port
H	Isolation

### NOTE:

1. H = HIGH Voltage Level  
L = LOW Voltage Level

## OPERATING CHARACTERISTICS, T<sub>A</sub> = 25°C (1)

Symbol	Parameter	Test Conditions	Min.	Max.	Unit
V <sub>CC</sub>	Supply Voltage		2.3	3.6	V
V <sub>IH</sub>	High-Level Control Input Voltage	V <sub>CC</sub> = 2.3V to 2.7V	1.7	—	V
		V <sub>CC</sub> = 2.7V to 3.6V	2	—	
V <sub>IL</sub>	Low-Level Control Input Voltage	V <sub>CC</sub> = 2.3V to 2.7V	—	0.7	V
		V <sub>CC</sub> = 2.7V to 3.6V	—	0.8	
T <sub>A</sub>	Operating Free-Air Temperature		-40	85	°C

### NOTE:

1. All unused control inputs of the device must be held at V<sub>CC</sub> or GND to ensure proper device operation.

## DC ELECTRICAL CHARACTERISTICS OVER OPERATING RANGE

Following Conditions Apply Unless Otherwise Specified:

Operating Conditions:  $T_A = -40^{\circ}\text{C}$  to  $+85^{\circ}\text{C}$

Symbol	Parameter	Test Conditions		Min.	Typ. <sup>(1)</sup>	Max.	Unit
$V_{IK}$	Control Inputs, Data Inputs	$V_{CC} = 3V$ , $I_I = -18\text{mA}$		—	—	-1.2	V
$I_I$	Control Inputs	$V_{CC} = 3.6V$ , $V_I = V_{CC}$ or GND		—	—	$\pm 1$	$\mu\text{A}$
$I_{OZ}$	Data I/O	$V_{CC} = 3.6V$ , $V_O = 0$ or $3.6V$ , switch disabled		—	—	5	$\mu\text{A}$
$I_{OFF}$		$V_{CC} = 0$ , $V_I$ or $V_O = 0$ to $3.6V$		—	—	50	$\mu\text{A}$
$I_{CC}$		$V_{CC} = 3.6V$ , $I_O = 0$ , $V_I = V_{CC}$ or GND		—	—	10	$\mu\text{A}$
$\Delta I_{CC}^{(2)}$	Control Inputs	$V_{CC} = 3.6V$ , one input at $3V$ , other inputs at $V_{CC}$ or GND		—	—	300	$\mu\text{A}$
$C_I$	Control Inputs	$V_I = 3V$ or $0$		—	4	—	pF
$C_{I(OFF)}$		$V_O = 3V$ or $0$ , $\overline{OE} = V_{CC}$		—	6	—	pF
$R_{ON}^{(3)}$	$V_{CC} = 2.3V$ Typ. at $V_{CC} = 2.5V$	$V_I = 0$	$I_O = 64\text{mA}$	—	5	8	$\Omega$
			$I_O = 24\text{mA}$	—	5	8	
	$V_{CC} = 3V$	$V_I = 1.7V$	$I_O = 15\text{mA}$	—	27	40	
			$I_O = 64\text{mA}$	—	5	7	
		$V_I = 2.4V$	$I_O = 24\text{mA}$	—	5	7	
			$I_O = 15\text{mA}$	—	10	15	

### NOTES:

1. Typical values are at  $V_{CC} = 3.3V$ ,  $+25^{\circ}\text{C}$  ambient.
2. The increase in supply current is attributable to each current that is at the specified voltage level rather than  $V_{CC}$  or GND.
3. This is measured by the voltage drop between the A and B terminals at the indicated current through the switch.

## SWITCHING CHARACTERISTICS

Symbol	Parameter	$V_{CC} = 2.5V \pm 0.2V$		$V_{CC} = 3.3V \pm 0.3V$		Unit
		Min.	Max.	Min.	Max.	
$t_{PD}^{(1)}$	Propagation Delay A to B or B to A	—	0.15	—	0.25	ns
$t_{EN}$	Output Enable Time $\overline{OE}$ to A or B	1	4.5	1	4.2	ns
$t_{DIS}$	Output Disable Time $\overline{OE}$ to A or B	1	5	1	5	ns

### NOTE:

1. The propagation delay is the calculated RC time constant of the typical on-state resistance of the switch and the specified load capacitance driven by an ideal voltage source (zero output impedance).

## TEST CIRCUITS AND WAVEFORMS

### TEST CONDITIONS

Symbol	V <sub>CC</sub> <sup>(1)</sup> = 3.3V±0.3V	V <sub>CC</sub> <sup>(2)</sup> = 2.5V±0.2V	Unit
V <sub>LOAD</sub>	6	2 x V <sub>CC</sub>	V
V <sub>IH</sub>	3	V <sub>CC</sub>	V
V <sub>T</sub>	1.5	V <sub>CC</sub> / 2	V
V <sub>LZ</sub>	300	150	mV
V <sub>HZ</sub>	300	150	mV
C <sub>L</sub>	50	30	pF

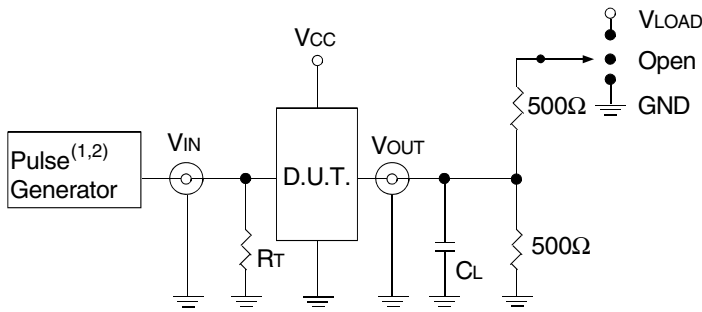

Test Circuits for All Outputs

#### DEFINITIONS:

C<sub>L</sub> = Load capacitance: includes jig and probe capacitance.  
R<sub>T</sub> = Termination resistance: should be equal to Z<sub>OUT</sub> of the Pulse Generator.

#### NOTES:

1. Pulse Generator for All Pulses: Rate ≤ 10MHz; t<sub>r</sub> ≤ 2.5ns; t<sub>f</sub> ≤ 2.5ns.
2. Pulse Generator for All Pulses: Rate ≤ 10MHz; t<sub>r</sub> ≤ 2ns; t<sub>f</sub> ≤ 2.5ns.

### SWITCH POSITION

Test	Switch
t <sub>PLZ</sub> /t <sub>PZL</sub>	V <sub>LOAD</sub>
t <sub>PHZ</sub> /t <sub>PZH</sub>	GND
t <sub>PD</sub>	Open

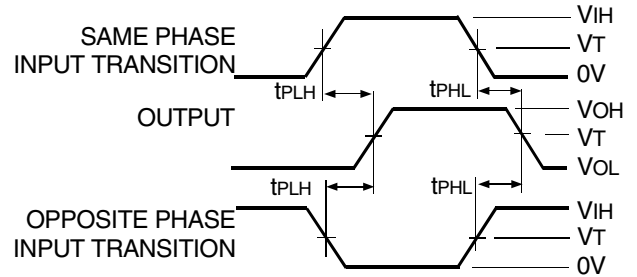

Propagation Delay

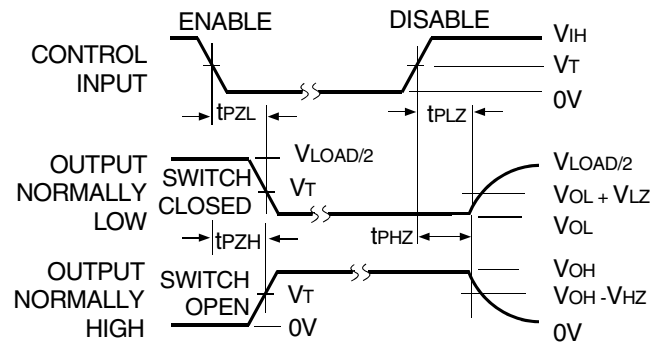

Enable and Disable Times

## ORDERING INFORMATION

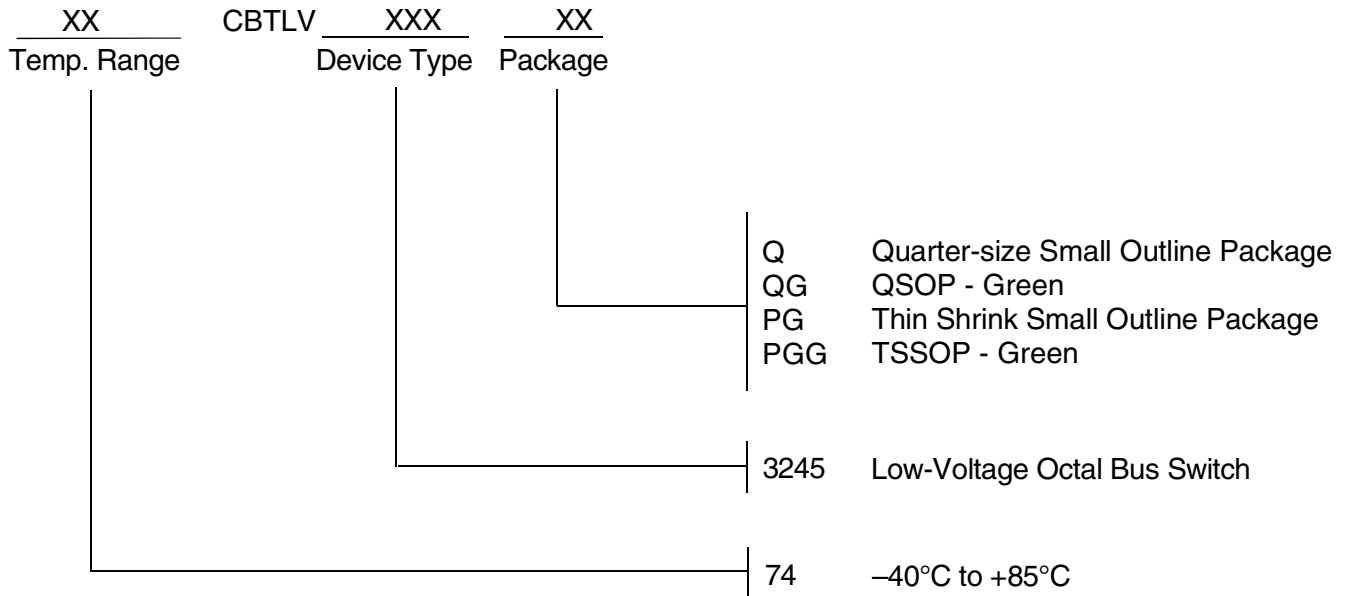

**CORPORATE HEADQUARTERS**  
6024 Silver Creek Valley Road  
San Jose, CA 95138

**for SALES:**  
800-345-7015 or 408-284-8200  
fax: 408-284-2775  
www.idt.com

**for Tech Support:**  
logichelp@idt.com