



3.3 VOLT TIME SLOT INTERCHANGE DIGITAL SWITCH 1,024 x 1,024

IDT72V70210

FEATURES:

- 32 serial input and output streams
- 1,024 x 1,024 channel non-blocking switching at 2.048 Mb/s
- Per-channel Variable Delay Mode for low-latency applications
- Per-channel Constant Delay Mode for frame integrity applications
- Automatic identification of ST-BUS® and GCI serial streams
- Automatic frame offset delay measurement
- Per-stream frame delay offset programming
- Per-channel high impedance output control
- Per-channel processor mode to allow microprocessor writes to TX streams
- Direct microprocessor access to all internal memories
- Memory block programming for quick set-up
- IEEE-1149.1 (JTAG) Test Port
- Internal Loopback for testing
- Available in 144-pin Ball Grid Array (BGA) and 144-pin Thin Quad

Flatpack (TQFP) packages

- Operating Temperature Range -40°C to +85°C
- 3.3V I/O with 5V tolerant inputs and TTL compatible outputs

DESCRIPTION:

The IDT72V70210 has a non-blocking switch capacity of 1,024 x 1,024 channels at 2.048 Mb/s. With 32 inputs and 32 outputs, programmable per stream control, and a variety of operating modes the IDT72V70210 is designed for the TDM time slot interchange function in either voice or data applications.

Some of the main features of the IDT72V70210 are low power 3.3 Volt operation, automatic ST-BUS®/GCI sensing, memory block programming, simple microprocessor interface, one cycle direct internal memory accesses, JTAG Test Access Port (TAP) and per stream programmable input offset delay, variable or constant throughput modes, internal loopback, output enable, and Processor Mode.

FUNCTIONAL BLOCK DIAGRAM

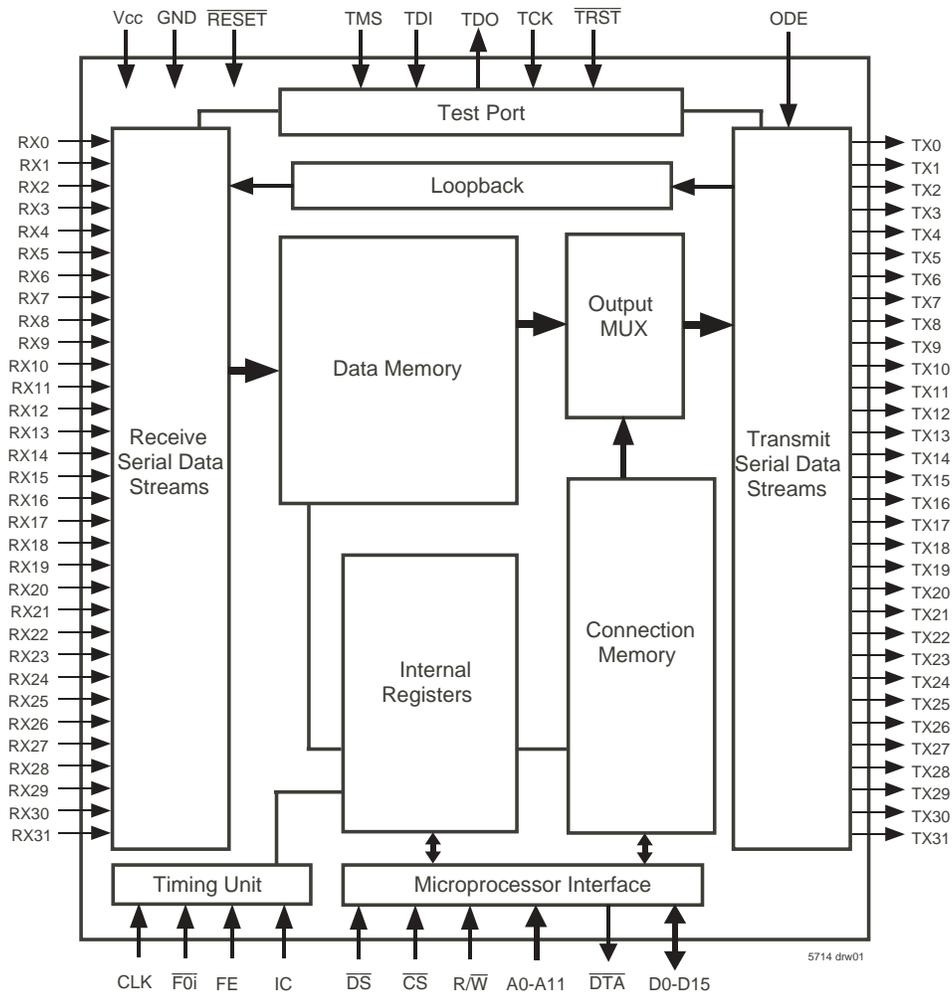

PIN CONFIGURATIONS

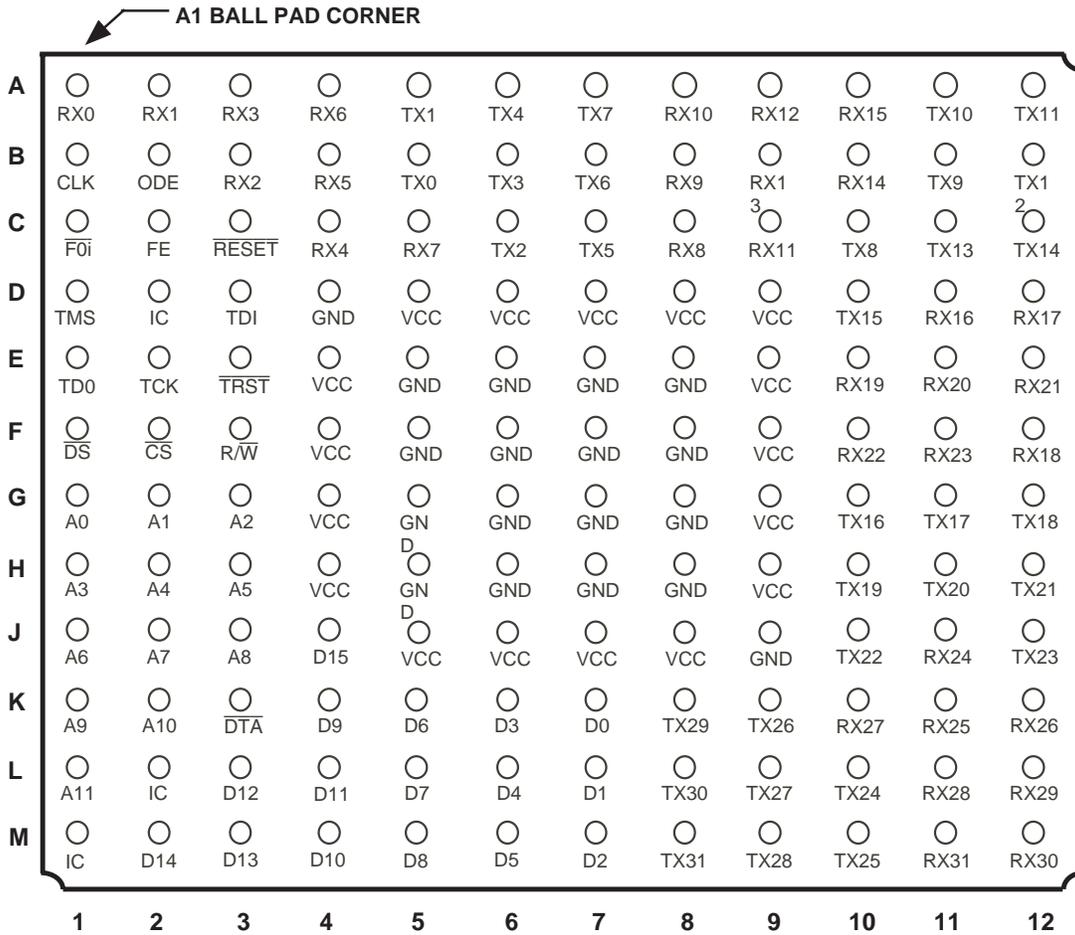

5714 drw 02

NOTE:

1. All I/O pins are 5V tolerant except for TMS, TDI and $\overline{\text{TRST}}$.

BGA: 1mm pitch, 13mm x 13mm (BC144-1, order code: BC)
TOP VIEW

PIN CONFIGURATIONS (CONTINUED)

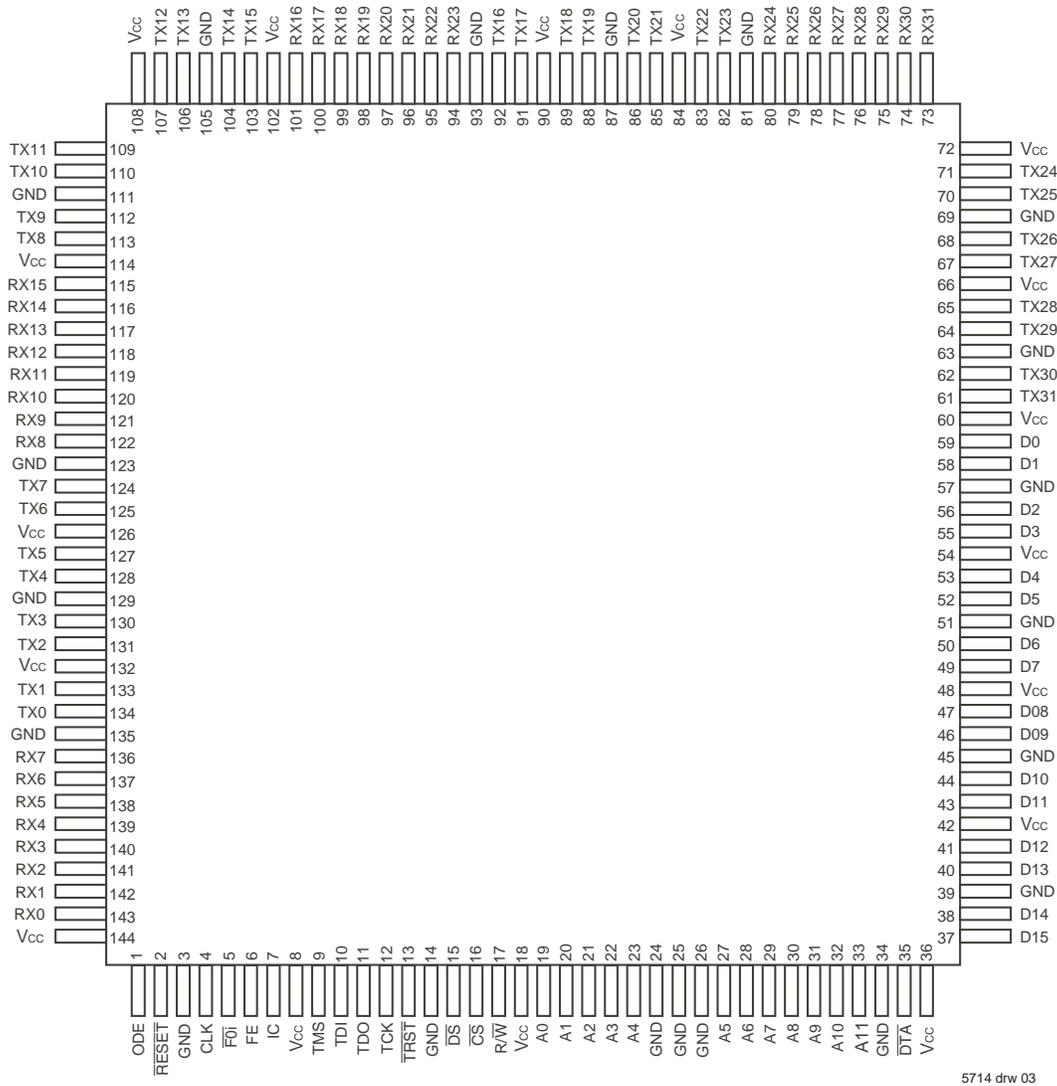

5714 drw 03

NOTE:

1. All I/O pins are 5V tolerant except for TMS, TDI and TRST.

TQFP: 0.50mm pitch, 20mm x 20mm (DA144-1, order code: DA)
TOP VIEW

PIN DESCRIPTION

SYMBOL	NAME	I/O	DESCRIPTION
GND	Ground.		Ground Rail.
Vcc	Vcc		+3.3 Volt Power Supply.
TX0-31	TX Output 0 to 31 (Three-state Outputs)	O	Serial data output stream. These streams have a data rate of 2.048 Mb/s.
RX0-31	RX Input 0 to 31	I	Serial data input stream. These streams have a data rate of 2.048 Mb/s.
$\overline{F0i}$	Frame Pulse	I	This input accepts and automatically identifies frame synchronization signals formatted according to ST-BUS® and GCI specifications.
FE	Frame Evaluation	I	This pin is the frame measurement input.
CLK	Clock	I	Serial clock for shifting data in/out on the serial streams (RX/TX 0-31). This input accepts a 4.096 MHz clock.
TMS	Test Mode Select	I	JTAG signal that controls the state transitions of the TAP controller. This pin is pulled HIGH by an internal pull-up when not driven.
TDI	Test Serial Data In	I	JTAG serial test instructions and data are shifted in on this pin. This pin is pulled HIGH by an internal pull-up when not driven.
TDO	Test Serial Data Out	O	JTAG serial data is output on this pin on the falling edge of TCK. This pin is held in high-impedance state when JTAG scan is not enabled.
TCK	Test Clock	I	Provides the clock to the JTAG test logic.
\overline{TRST}	Test Reset	I	Asynchronously initializes the JTAG TAP controller by putting it in the Test-Logic-reset state. This pin is pulled by an internal pull-up when not driven. This pin should be pulsed LOW on power-up, or held LOW, to ensure that the IDT72V70210 is in the normal functional mode.
\overline{RESET}	Device Reset (Schmitt Trigger Input)	I	This input (active LOW) puts the IDT72V70210 in its reset state that clears the device internal counters, registers and brings TX0-31 and microport data outputs to a high-impedance state. The time constant for a power up reset circuit must be a minimum of five times the rise time of the power supply. In normal operation, the \overline{RESET} pin must be held LOW for a minimum of 100ns to reset the device.
\overline{DS}	Data Strobe	I	This active LOW input works in conjunction with \overline{CS} to enable the read and write operations.
R/\overline{W}	Read/Write	I	This input controls the direction of the data bus lines during a microprocessor access.
\overline{CS}	Chip Select	I	Active LOW input used by a microprocessor to activate the microprocessor port of IDT72V70210.
A0-11	Address Bus 0 to 11	I	These pins allow direct access to Connection Memory, Data Memory and internal control registers.
D0-15	Data Bus 0-15	I/O	These pins are the data bits of the microprocessor port.
\overline{DTA}	Data Transfer Acknowledgment	O	This active LOW signal indicates that a data bus transfer is complete. When the bus cycle ends, this pin drives HIGH and then goes high-impedance, allowing for faster bus cycles with a weaker pull-up resistor. A pull-up resistor is required to hold a HIGH level when the pin is in high-impedance.
ODE	Output Drive Enable	I	This is the output enable control for the TX0-31 serial outputs. When ODE input is LOW and the OSB bit of the CR register is LOW, TX0-31 are in a high-impedance state. If this input is HIGH, the TX0-31 output drivers are enabled. However, each channel may still be put into a high-impedance state by using the per channel control bit in the connection memory.
IC	Internal Connection	I	This pin tied to Ground for normal/JTAG operations

DESCRIPTION (CONTINUED):

The IDT72V70210 is capable of switching up to 1,024 x 1,024 channels without blocking. Designed to switch 64 Kbit/s PCM or N x 64 Kbit/s data, the device maintains frame integrity in data applications and minimizes throughput delay for voice applications on a per channel basis.

The 32 serial input streams (RX) of the IDT72V70210 can be run 2.048 Mb/s allowing 32 channels per 125 μ s frame. The data rates on the output streams (TX) are identical to those on the input stream.

With two main operating modes, Processor Mode and Connection Mode, the IDT72V70210 can easily switch data from incoming serial streams (Data Memory) or from the controlling microprocessor (Connection Memory). As control and status information is critical in data transmission, the Processor Mode is especially useful when there are multiple devices sharing the input and output streams.

With data coming from multiple sources and through different paths, data entering the device is often delayed. To handle this problem, the IDT72V70210 has a frame evaluation feature to allow individual streams to be offset from the frame pulse in half clock-cycle intervals up to +4.5 clock cycles.

The IDT72V70210 also provides a JTAG test access port, an internal loopback feature, memory block programming, a simple microprocessor interface and automatic ST-BUS[®]/GCI sensing to shorten setup time, aid in debugging and ease use of the device without sacrificing capabilities.

FUNCTIONAL DESCRIPTION

DATA AND CONNECTION MEMORY

All data that comes in through the RX inputs go through a serial-to-parallel conversion before being stored into internal Data Memory. The 8 KHz frame pulse (\overline{FO}) is used to mark the 125 μ s frame boundaries and to sequentially address the input channels in Data Memory.

Data output on the TX streams may come from either the Serial Input Streams, RX0-31, (Data Memory) or from the microprocessor (Connection Memory). In the case that RX input data is to be output, the addresses in connection memory are used to specify a stream and channel of the input. The connection memory is setup in such a way that each location corresponds to an output channel for each particular stream. In that way, more than one channel can output the same data.

In Processor Mode, the microprocessor writes data to the connection memory locations corresponding to the stream and channel that is to be output. The lower half (8 least significant bits) of the connection memory is output every frame until the microprocessor changes the data or mode of the channel. By using this Processor Mode capability, the microprocessor can access input and output time-slots on a per channel basis.

The four most significant bits of the connection memory are used to control per channel functions of the output streams. Specifically, there are bits for Processor or Connection mode, Constant or Variable delay, enables or disables of output drivers, and controls for the Loopback function.

If the per channel OE is set to zero, only that particular channel (8-bits) will be in the high-impedance state. If however, the ODE input pin is low or the Output Standby Bit (OSB) in the Control Register is low, all of the outputs will be in a high-impedance state even if a particular channel in connection memory has enabled the output for that channel. In other words, the ODE pin and OSB control bit are master output enables for the device (Table 3).

SERIAL DATA INTERFACE TIMING

The master clock frequency must always be twice the data rate. For a serial data rates of 2.048 Mb/s, the master clock (CLK) must be at 4.096 MHz. The input and output stream data rates will always be identical.

The IDT72V70210 provides two different interface timing modes, ST-BUS[®] or GCI. The IDT72V70210 automatically detects the presence of an input frame pulse and identifies it as either ST-BUS[®] or GCI. In ST-BUS[®] format, every second falling edge of the master clock marks a bit boundary and the data is clocked in on the rising edge of CLK, three quarters of the way into the bit cell. In GCI format, every second rising edge of the master clock marks the bit boundary and data is clocked in on the falling edge of CLK at three quarters of the way into the bit cell.

INPUT FRAME OFFSET SELECTION

Input frame offset selection allows the channel alignment of individual input streams to be offset with respect to the output stream channel alignment (i.e. \overline{FO}). Although all input data comes in at the same speed, delays can be caused by variable path serial backplanes and variable path lengths which may be implemented in large centralized and distributed switching systems. Because data is often delayed this feature is useful in compensating for the skew between clocks.

Each input stream can have its own delay offset value by programming the frame input offset registers (FOR, Table 8). The maximum allowable skew is +4 master clock (CLK) periods forward with a resolution of 1/2 clock period. The output frame offset cannot be offset or adjusted.

SERIAL INPUT FRAME ALIGNMENT EVALUATION

The IDT72V70210 provides the frame evaluation (FE) input to determine different data input delays with respect to the frame pulse \overline{FO} .

A measurement cycle is started by setting the start frame evaluation (SFE) bit low for at least one frame. When the SFE bit in the Control Register is changed from low to high, the evaluation starts. Two frames later, the complete frame evaluation (CFE) bit of the frame alignment register (FAR) changes from low to high to signal that a valid offset measurement is ready to be read from bits 0 to 11 of the FAR register. The SFE bit must be set to zero before a new measurement cycle is started.

In ST-BUS[®] mode, the falling edge of the frame measurement signal (FE) is evaluated against the falling edge of the ST-BUS[®] frame pulse. In GCI mode, the rising edge of FE is evaluated against the rising edge of the GCI frame pulse. See Table 7 and Figure 1 for the description of the frame alignment register.

MEMORY BLOCK PROGRAMMING

The IDT72V70210 provides users with the capability of initializing the entire connection memory block in two frames. To set bits 12 to 15 of every connection memory location, first program the desired pattern in bits 5 to 8 of the Control Register.

The block programming mode is enabled by setting the memory block program (MBP) bit of the control register high. When the block programming enable (BPE) bit of the Control Register is set to high, the block programming data will be loaded into the bits 12 to 15 of every connection memory location. The other connection memory bits (bit 0 to bit 11) are loaded with zeros. When the memory block programming is complete, the device resets the BPE bit to zero.

LOOPBACK CONTROL

The loopback control (LPBK) bit of each connection memory location allows the TX output data to be looped back internally to the RX input for diagnostic purposes.

If the LPBK bit is high, the associated TX output channel data is internally looped back to the RX input channel (i.e., data from TXn channel m routes to the RXn channel m internally); if the LPBK bit is low, the loopback feature is

disabled. For proper per-channel loopback operation, the contents of frame delay offset registers must be set to zero.

DELAY THROUGH THE IDT72V70210

The switching of information from the input serial streams to the output serial streams results in a throughput delay. The device can be programmed to perform time-slot interchange functions with different throughput delay capabilities on a per-channel basis. For voice applications, variable throughput delay is best as it ensures minimum delay between input and output data. In wideband data applications, constant throughput delay is best as the frame integrity of the information is maintained through the switch.

The delay through the device varies according to the type of throughput delay selected in the \bar{V}/C bit of the connection memory.

VARIABLE DELAY MODE (\bar{V}/C BIT = 0)

In this mode, the delay is dependent only on the combination of source and destination channels and is independent of input and output streams. The minimum delay achievable in the IDT72V70210 is three time-slots. If the input channel data is switched to the same output channel (channel n , frame p), it will be output in the following frame (channel n , frame $p+1$). The same is true if the input channel n is switched to output channel $n+1$ or $n+2$. If the input channel n is switched to output channel $n+3$, $n+4$, ..., the new output data will appear in the same frame. Table 2 shows the possible delays for the IDT72V70210 in the variable delay mode.

CONSTANT DELAY MODE (\bar{V}/C BIT = 1)

In this mode, frame integrity is maintained in all switching configurations by making use of a multiple data memory buffer. Input channel data is written into the data memory buffers during frame n will be read out during frame $n+2$. In the IDT72V70210, the minimum throughput delay achievable in the constant delay mode will be one frame. For example, when input time-slot 31 is switched to output time-slot 0. The maximum delay of 94 time-slots of delay occurs when time-slot 0 in a frame is switched to time-slot 31 in the frame.

MICROPROCESSOR INTERFACE

The IDT72V70210's microprocessor interface looks like a standard RAM interface to improve integration into a system. With a 12-bit address bus and a 16-bit data bus, read and writes are mapped directly into Data and Connection memories and require only one cycle to access. By allowing the internal memories to be randomly accessed in one cycle, the controlling microprocessor has more time to manage other peripheral devices and can more easily and quickly gather information and setup the switch paths.

Table 4 shows the mapping of the addresses into internal memory blocks and Table 5 shows the Control Register information.

MEMORY MAPPING

The address bus on the microprocessor interface selects the internal registers and memories of the IDT72V70210.

The two most significant bits of the address select between the registers, Data Memory, and Connection Memory. If A11 and A10 are HIGH, A9-A0 are used to address the Data Memory. If A11 is HIGH and A10 is LOW, A9-A0 are used to address Connection Memory. If A11 is LOW and A10 is HIGH A9-A0 are used to select the Control Register, Frame Alignment Register, and Frame Offset Registers. See Table 4 for mappings.

As explained in the Serial Data Interface Timing and Switching Configurations sections, after system power-up, the Control Register should be programmed immediately to establish the desired switching configuration.

The data in the Control Register consists of the Memory Block Programming bit (MBP), the Block Programming Data (BPE) bits, the Begin Block Programming Enable (BPE), the Output Stand By, Start Frame Evaluation, and Data Rate Select bits. As explained in the Memory Block Programming section, the BPE begins the programming if the MBP bit is enabled. This allows the entire connection memory block to be programmed with the Block Programming Data bits. If the ODE pin is low, the OSB bit enables (if high) or disables (if low) all TX output drivers. If the ODE pin is high, the contents of the OSB bit is ignored and all TX output drivers are enabled.

CONNECTION MEMORY CONTROL

If the ODE pin or the OSB bit is high, the OE bit of each connection memory location controls the output drivers-enables (if high) or disables (if low). See Table 3 for detail.

The Processor Channel (PC) bit of the Connection Memory selects between Processor Mode and Connection Mode. If high, the contents of the Connection Memory are output on the TX streams. If low, the Stream Address Bit (SAB) and the Channel Address Bit (CAB) of the Connection Memory defines the source information (stream and channel) of the time-slot that will be switched to the output from Data Memory.

Also in the Connection Memory is the \bar{V}/C (Variable/Constant Delay) bit. Each Connection Memory location allows the per-channel selection between variable and constant throughput delay modes.

If the LPBK bit is high, the associated TX output channel data is internally looped back to the RX input channel (i.e., RX n channel m data comes from the TX n channel m). If the LPBK bit is low, the loopback feature is disabled. For proper per-channel loopback operation, the contents of the frame delay offset registers must be set to zero.

INITIALIZATION OF THE IDT72V70210

After power up, the state of the connection memory is unknown. As such, the outputs should be put in high impedance by holding the ODE low. While the ODE is low, the microprocessor can initialize the device, program the active paths, and disable unused outputs by programming the OE bit in connection memory. Once the device is configured, the ODE pin (or OSB bit depending on initialization) can be switched.

TABLE 1 — CONSTANT THROUGHPUT DELAY VALUE

Input Rate	Delay for Constant Throughput Delay Mode (m – output channel number) (n – input channel number)
2.048 Mb/s	32 + (32 – n) + m time-slots

TABLE 2 — VARIABLE THROUGHPUT DELAY VALUE

Input Rate	Delay for Variable Throughput Delay Mode (m – output channel number; n – input channel number)		
	m < n	m = n, n+1, n+2	m > n+2
2.048 Mb/s	32 – (n-m) time-slots	(m-n + 32) time slots	(m-n) time-slots

TABLE 3 — OUTPUT HIGH IMPEDANCE CONTROL

OE bit in Connection Memory	ODE pin	OSB bit in CR Register	TX Stream Output Status
0	Don't Care	Don't Care	PerChannel High-Impedance
1	0	0	High-Impedance
1	0	1	Enable
1	1	0	Enable
1	1	1	Enable

TABLE 4 — INTERNAL REGISTER AND ADDRESS MEMORY MAPPING

A11	A10	A9	A8	A7	A6	A5	A4	A3	A2	A1	A0	R/W	Location
1	1	STA4	STA3	STA2	STA1	STA0	CH4	CH3	CH2	CH1	CH0	R	Data Memory
1	0	STA4	STA3	STA2	STA1	STA0	CH4	CH3	CH2	CH1	CH0	R/W	Connect. Memory
0	1	0	0	0	0	x	x	x	x	x	x	R/W	Control Register
0	1	0	0	0	1	x	x	x	x	x	x	R/W	Frame Align Register
0	1	0	0	1	0	x	x	x	x	x	x	R/W	FOR0
0	1	0	0	1	1	x	x	x	x	x	x	R/W	FOR1
0	1	0	1	0	0	x	x	x	x	x	x	R/W	FOR2
0	1	0	1	0	1	x	x	x	x	x	x	R/W	FOR3
0	1	0	1	1	0	x	x	x	x	x	x	R/W	FOR4
0	1	0	1	1	1	x	x	x	x	x	x	R/W	FOR5
0	1	1	0	0	0	x	x	x	x	x	x	R/W	FOR6
0	1	1	0	0	1	x	x	x	x	x	x	R/W	FOR7

TABLE 5 — CONTROL REGISTER (CR) BITS

Reset Value:		0000h.																		
15	14	13	12	11	10	9	8	7	6	5	4	3	2	1	0					
0		0		0		0		0		MBP		BPD3	BPD2	BPD1	BPD0	BPE	OSB	SFE	0	0
Bit	Name	Description																		
15-10	Unused	Must be zero for normal operation.																		
9	MBP (Memory Block Program)	When 1, the connection memory block programming feature is ready for the programming of Connection Memory high bits, bit 11 to bit 15. When 0, this feature is disabled.																		
8-5	BPD4-0 (Block Programming Data)	These bits carry the value to be loaded into the connection memory block whenever the memory block programming feature is activated. After the MBP bit in the control register is set to 1 and the BPE bit is set to 1, the contents of the bits BPD3-0 are loaded into bit 15 and 12 of the connection memory. Bit 11 to bit 0 of the connection memory are set to 0.																		
4	BPE (Begin Block Programming Enable)	A zero to one transition of this bit enables the memory block programming function. The BPE and BPD4-0 bits in the CR register have to be defined in the same write operation. Once the BPE bit is set HIGH, the device requires two frames to complete the block programming. After the programming function has finished, the BPE bit returns to zero to indicate the operation is completed. When the BPE = 1, the BPE or MBP can be set to 0 to abort to ensure proper operation. When BPE = 1, the other bit in the CR register must not be changed for two frames to ensure proper operation.																		
3	OSB (Output Stand By)	When ODE = 0 and OSB = 0, the output drivers of TX0 to TX31 are in high impedance mode. When ODE = 0 and OSB = 1, the output driver of TX0 to TX31 function normally. When ODE = 1, TX0 to TX31 output drivers function normally.																		
2	SFE (Start Frame Evaluation)	A zero to one transition in this bit starts the frame evaluation procedure. When the CFE bit in the FAR register changes from zero to one, the evaluation procedure stops. To start another frame evaluation cycle, set this bit to zero for at least one frame.																		
1-0	Unused	Must be zero for normal operation.																		

TABLE 6 — CONNECTION MEMORY BITS

15	14	13	12	11	10	9	8	7	6	5	4	3	2	1	0		
LPBK		\bar{V}/C	PC	OE	SAB4	SAB3	SAB2	SAB1	SAB0	0		0	CAB4	CAB3	CAB2	CAB1	CAB0
Bit	Name	Description															
15	LPBK (PerChannelLoopback)	When 1, the RX n channel m data comes from the TX n channel m. For proper per channel loopback operations, set the delay offset register bits OFn[2:0] to zero for the streams which are in the loopback mode.															
14	\bar{V}/C (Variable/Constant Throughput Delay)	This bit is used to select between the variable (LOW) and constant delay (HIGH) mode on a per-channel basis.															
13	PC (Processor Channel)	When 1, the contents of the connection memory are output on the corresponding output channel and stream. Only the lower byte (bit 7 – bit 0) will be output to the TX output pins. When 0, the contents of the connection memory are the data memory address of the switched input channel and stream.															
12	OE (Output Enable)	This bit enables the TX output drivers on a per-channel basis. When 1, the output driver functions normally. When 0, the output driver is in a high-impedance state.															
11-7	SAB4-0 (Source Stream Address Bits)	The binary value is the number of the data stream for the source of the connection.															
6-5	Unused	Must be zero for normal operation.															
4-0	CAB4-0 (Source Channel Address Bits)	The binary value is the number of the channel for the source of the connection.															

TABLE 7 — FRAME ALIGNMENT REGISTER (FAR) BITS

Reset Value:		0000h.														
	15	14	13	12	11	10	9	8	7	6	5	4	3	2	1	0
	0	0	0	CFE	FD11	FD10	FD9	FD8	FD7	FD6	FD5	FD4	FD3	FD2	FD1	FD0
Bit	Name	Description														
15-13	Unused	Must be zero for normal operation														
12	CFE (Complete Frame Evaluation)	When CFE = 1, the frame evaluation is completed and bits FD10 to FD0 bits contains a valid frame alignment offset. This bit is reset to zero, when SFE bit in the CR register is changed from 1 to 0.														
11	FD11 (Frame Delay Bit 11)	The falling edge of FE (or rising edge for GCI mode) is sampled during the CLK-high phase (FD11 = 1) or during the CLK-low phase (FD11 = 0). This bit allows the measurement resolution to ½ CLK cycle.														
10-0	FD10-0 (Frame Delay Bits)	The binary value expressed in these bits refers to the measured input offset value. These bits are reset to zero when the SFE bit of the CR register changes from 1 to 0. (FD10 – MSB, FD0 – LSB)														

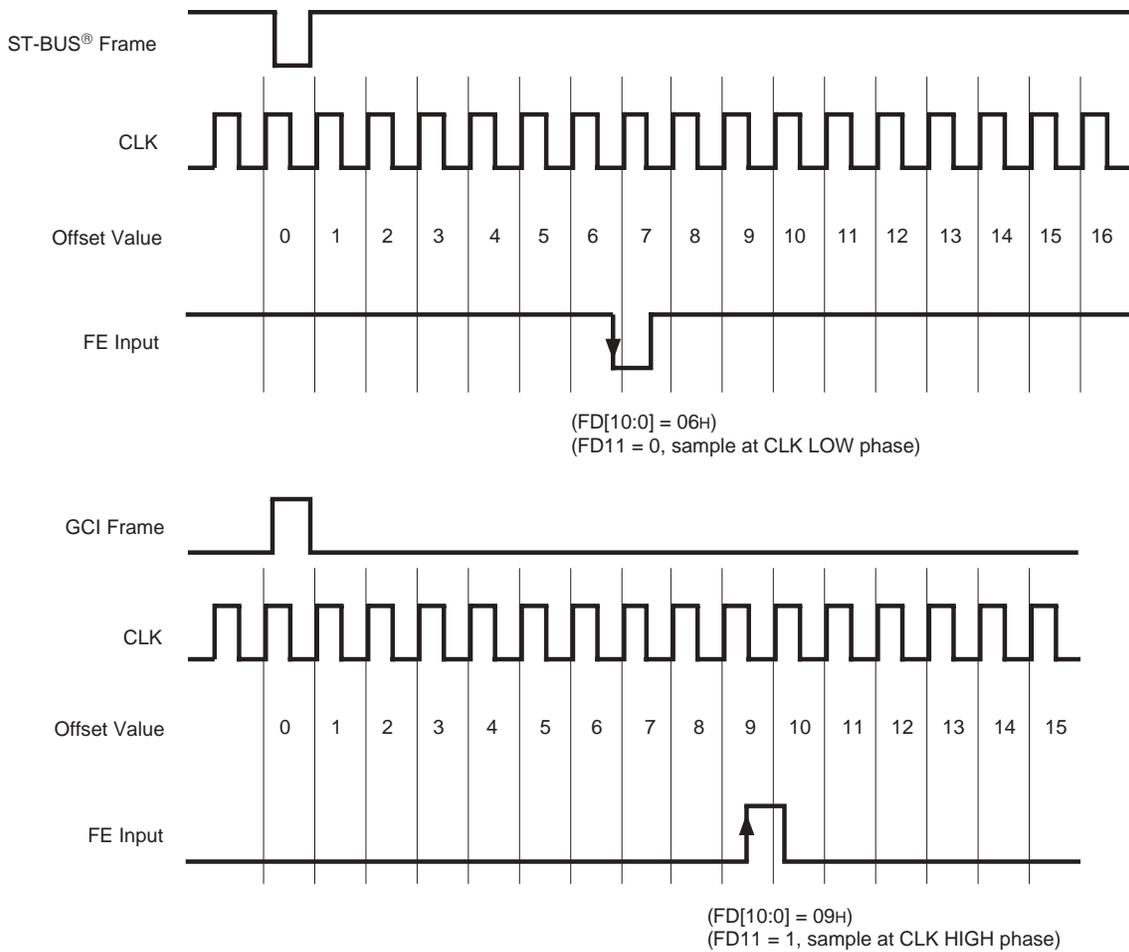

5714 drw 04

Figure 1. Example for Frame Alignment Measurement

TABLE 8 — FRAME INPUT OFFSET REGISTER (FOR) BITS

Reset Value: 0000_H for all FOR registers.

15	14	13	12	11	10	9	8	7	6	5	4	3	2	1	0
OF32	OF31	OF30	DLE3	OF22	OF21	OF20	DLE2	OF12	OF11	OF10	DLE1	OF02	OF01	OF00	DLE0
FOR0 Register															
15	14	13	12	11	10	9	8	7	6	5	4	3	2	1	0
OF72	OF71	OF70	DLE7	OF62	OF61	OF60	DLE6	OF52	OF51	OF50	DLE5	OF42	OF41	OF40	DLE4
FOR1 Register															
15	14	13	12	11	10	9	8	7	6	5	4	3	2	1	0
OF112	OF111	OF110	DLE11	OF102	OF101	OF100	DLE10	OF92	OF91	OF90	DLE9	OF82	OF81	OF80	DLE8
FOR2 Register															
15	14	13	12	11	10	9	8	7	6	5	4	3	2	1	0
OF312	OF311	OF310	DLE31	OF142	OF141	OF140	DLE14	OF132	OF131	OF130	DLE13	OF122	OF121	OF120	DLE12
FOR3 Register															
15	14	13	12	11	10	9	8	7	6	5	4	3	2	1	0
OF192	OF191	OF190	DLE19	OF182	OF181	OF180	DLE18	OF172	OF171	OF170	DLE17	OD162	OD161	OF160	DLE16
FOR4 Register															
15	14	13	12	11	10	9	8	7	6	5	4	3	2	1	0
OF232	OF231	OF230	DLE23	OF222	OF221	OF220	DLE22	OF212	OF211	OF210	DLE21	OF202	OF201	OF200	DLE20
FOR5 Register															
15	14	13	12	11	10	9	8	7	6	5	4	3	2	1	0
OF272	OF271	OF270	DLE27	OF262	OF261	OF260	DLE26	OF252	OF251	OF250	DLE25	OF242	OF241	OF240	DLE24
FOR6 Register															
15	14	13	12	11	10	9	8	7	6	5	4	3	2	1	0
OF312	OF311	OF310	DLE31	OF302	OF301	OF300	DLE30	OF292	OF291	OF290	DLE29	OF282	OF281	OF280	DLE28
FOR7 Register															

Name ⁽¹⁾	Description
OFn2, OFn1, OFn0 (Offset Bits 2, 1 & 0)	These three bits define how long the serial interface receiver takes to recognize and store bit 0 from the RX input pin: i.e., to start a new frame. The input frame offset can be selected to +4.5 clock periods from the point where the external frame pulse input signal is applied to the $\overline{FO}i$ input of the device. See Figure 1.
DLEn	ST-BUS [®] mode: (Data Latch Edge) DLEn = 0, if clock rising edge is at the $\frac{3}{4}$ point of the bit cell. DLEn = 1, if when clock falling edge is at the $\frac{3}{4}$ of the bit cell. GCI mode: DLEn = 0, if clock falling edge is at the $\frac{3}{4}$ point of the bit cell. DLEn = 1, if when clock rising edge is at the $\frac{3}{4}$ of the bit cell.

NOTE:

1. n denotes an input stream number from 0 to 31.

TABLE 9 — OFFSET BITS (OFn2, OFn1, OFn0, DLEn) & FRAME DELAY BITS (FD11, FD2-0)

Input Stream Offset	Measurement Result from Frame Delay Bits				Corresponding Offset Bits			
	FD11	FD2	FD1	FD0	OFn2	OFn1	OFn0	DLEn
No clock period shift (Default)	1	0	0	0	0	0	0	0
+0.5 clock period shift	0	0	0	0	0	0	0	1
+1.0 clock period shift	1	0	0	1	0	0	1	0
+1.5 clock period shift	0	0	0	1	0	0	1	1
+2.0 clock period shift	1	0	1	0	0	1	0	0
+2.5 clock period shift	0	0	1	0	0	1	0	1
+3.0 clock period shift	1	0	1	1	0	1	1	0
+3.5 clock period shift	0	0	1	1	0	1	1	1
+4.0 clock period shift	1	1	0	0	1	0	0	0
+4.5 clock period shift	0	1	0	0	1	0	0	1

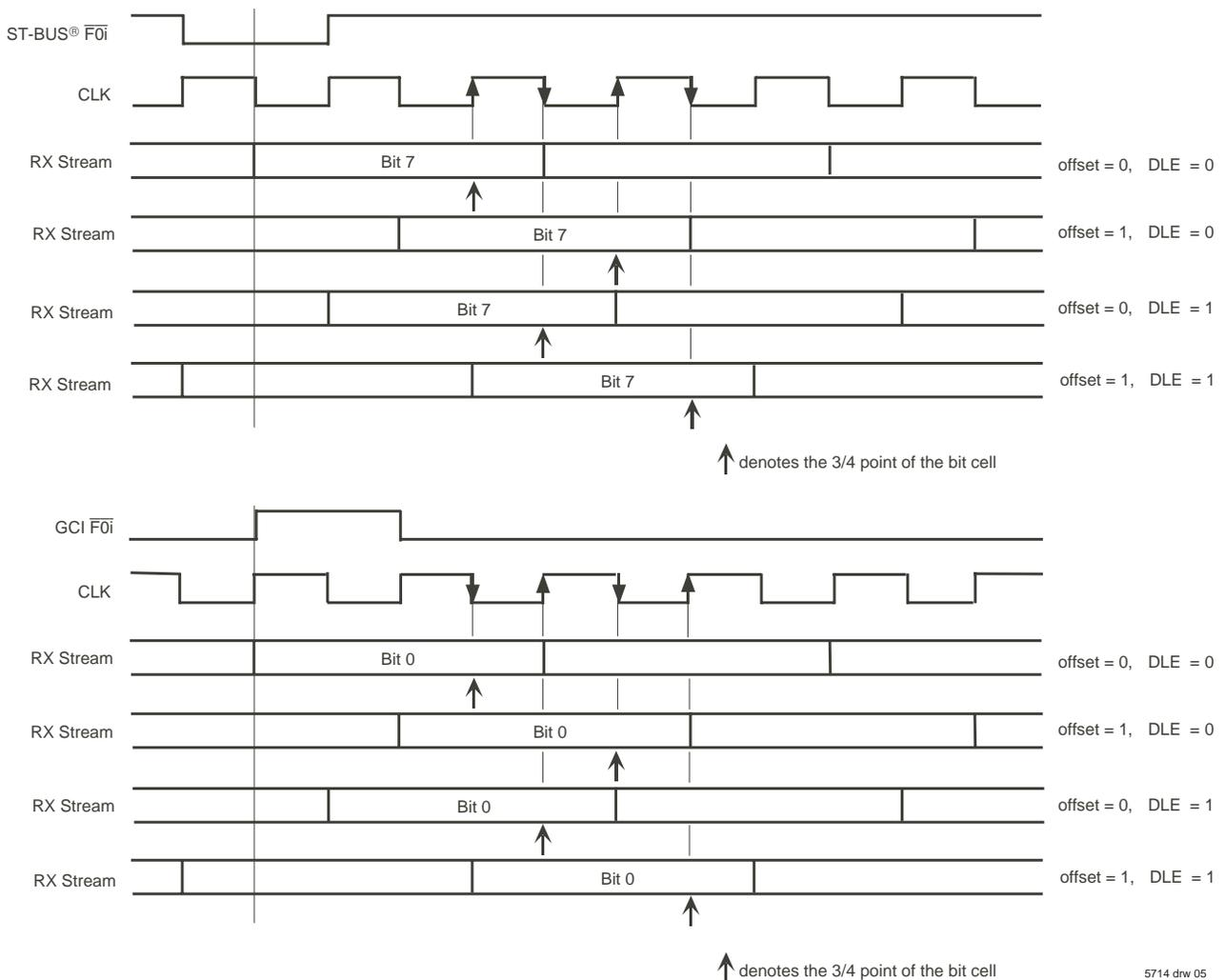

Figure 2. Examples for Input Offset Delay Timing

JTAG SUPPORT

The IDT72V70210 JTAG interface conforms to the Boundary-Scan standard IEEE-1149.1. This standard specifies a design-for-testability technique called Boundary-Scan test (BST). The operation of the boundary-scan circuitry is controlled by an external test access port (TAP) Controller.

TEST ACCESS PORT (TAP)

The Test Access Port (TAP) provides access to the test functions of the IDT72V70210. It consists of three input pins and one output pin.

- Test Clock Input (TCK)

TCK provides the clock for the test logic. The TCK does not interfere with any on-chip clock and thus remain independent. The TCK permits shifting of test data into or out of the Boundary-Scan register cells concurrently with the operation of the device and without interfering with the on-chip logic.

- Test Mode Select Input (TMS)

The logic signals received at the TMS input are interpreted by the TAP Controller to control the test operations. The TMS signals are sampled at the rising edge of the TCK pulse. This pin is internally pulled to Vcc when it is not driven from an external source.

- Test Data Input (TDI)

Serial input data applied to this port is fed either into the instruction register or into a test data register, depending on the sequence previously applied to the TMS input. Both registers are described in a subsequent section. The received input data is sampled at the rising edge of TCK pulses. This pin is internally pulled to Vcc when it is not driven from an external source.

- Test Data Output (TDO)

Depending on the sequence previously applied to the TMS input, the contents of either the instruction register or data register are serially shifted out

towards the TDO. The data out of the TDO is clocked on the falling edge of the TCK pulses. When no data is shifted through the boundary scan cells, the TDO driver is set to a high impedance state.

- Test Reset ($\overline{\text{TRST}}$)

Reset the JTAG scan structure. This pin is internally pulled to Vcc.

INSTRUCTION REGISTER

In accordance with the IEEE-1149.1 standard, the IDT72V70210 uses public instructions. The IDT72V70210 JTAG Interface contains a two-bit instruction register. Instructions are serially loaded into the instruction register from the TDI when the TAP Controller is in its shifted-IR state. Subsequently, the instructions are decoded to achieve two basic functions: to select the test data register that may operate while the instruction is current, and to define the serial test data register path, which is used to shift data between TDI and TDO during data register scanning.

TEST DATA REGISTER

As specified in IEEE-1149.1, the IDT72V70210 JTAG Interface contains two test data registers:

- The Boundary-Scan register

The Boundary-Scan register consists of a series of Boundary-Scan cells arranged to form a scan path around the boundary of the IDT72V70210 core logic.

- The Bypass Register

The Bypass register is a single stage shift register that provides a one-bit path from TDI to its TDO. The IDT72V70210 boundary scan register bits are shown in Table 10. Bit 0 is the first bit clocked out. All three-state enable bits are active high.

TABLE 10 — BOUNDARY SCAN REGISTER BITS

Device Pin	Boundary Scan Bit 0 to bit 167		
	Three-State Control	Output Scan Cell	Input Scan Cell
ODE			0
RESET			1
CLK			2
F _{0i}			3
FE			4
IC			5
DS			6
CS			7
R/W			8
A0			9
A1			10
A2			11
A3			12
A4			13
IC			14
IC			15
A5			16
A6			17
A7			18
A8			19
A9			20
A10			21
A11			22
DTA		23	
D15	24	25	26
D14	27	28	29
D13	30	31	32
D12	33	34	35
D11	36	37	38
D10	39	40	41
D9	42	43	44
D8	45	46	47
D7	48	49	50
D6	51	52	53
D5	54	55	56
D4	57	58	59
D3	60	61	62
D2	63	64	65
D1	66	67	68
D0	69	70	71
TX31	72	73	
TX30	74	75	
TX29	76	77	
TX28	78	79	
TX27	80	81	
TX26	82	83	
TX25	84	85	
TX24	86	87	
RX31			88
RX30			89
RX29			90
RX28			91

Device Pin	Boundary Scan Bit 0 to bit 167		
	Three-State Control	Output Scan Cell	Input Scan Cell
RX27			92
RX26			93
RX25			94
RX24			95
TX23	96	97	
TX22	98	99	
TX21	100	101	
TX20	102	103	
TX19	104	105	
TX18	106	107	
TX17	108	109	
TX16	110	111	
RX23			112
RX22			113
RX21			114
RX20			115
RX19			116
RX18			117
RX17			118
RX16			119
TX15	120	121	
TX14	122	123	
TX13	124	125	
TX12	126	127	
TX11	128	129	
TX10	130	131	
TX9	132	133	
TX8	134	135	
RX15			136
RX14			137
RX13			138
RX12			139
RX11			140
RX10			141
RX9			142
RX8			143
TX7	144	145	
TX6	146	147	
TX5	148	149	
TX4	150	151	
TX3	152	153	
TX2	154	155	
TX1	156	157	
TX0	158	159	
RX7			160
RX6			161
RX5			162
RX4			163
RX3			164
RX2			165
RX1			166
RX0			167

ABSOLUTE MAXIMUM RATINGS⁽¹⁾

Symbol	Parameter	Min.	Max.	Unit
VCC	Supply Voltage	3.0	3.6	V
Vi	Voltage on Digital Inputs	GND -0.3	5.3	V
Io	Current at Digital Outputs	-50	50	mA
Ts	Storage Temperature	-55	+125	°C
PD	Package Power Dissipation	—	2	W

NOTE:

1. Exceeding these values may cause permanent damage. Functional operation under these conditions is not implied.

RECOMMENDED OPERATING CONDITIONS⁽¹⁾

Symbol	Parameter	Min.	Typ.	Max.	Unit
VCC	Positive Supply	3.0	3.3	3.6	V
ViH	Input HIGH Voltage	2.0	—	5.3	V
ViL	Input LOW Voltage	—	—	0.8	V
TOP	Operating Temperature Commercial	-40	25	+85	°C

NOTE:

1. Voltages are with respect to Ground unless otherwise stated.

DC ELECTRICAL CHARACTERISTICS

Symbol	Parameter	Min.	Typ.	Max.	Units
I _{CC} ⁽²⁾	Supply Current @ 2 Mb/s	-	15	20	mA
I _{IL} ^(3,4)	Input Leakage (input pins)	-	-	50	μA
I _{OZ} ^(3,4)	High-impedance Leakage	-	-	50	μA
V _{OH} ⁽⁵⁾	Output HIGH Voltage	2.4	-	-	V
V _{OL} ⁽⁶⁾	Output LOW Voltage	-	-	0.4	V

NOTES:

1. Voltages are with respect to ground (GND) unless otherwise stated.
2. Outputs unloaded.
3. $0 \leq V \leq VCC$.
4. Maximum leakage on pins (output or I/O pins in high-impedance state) is over an applied voltage (V).
5. IOH = 10 mA.
6. IOL = 10 mA.

AC ELECTRICAL CHARACTERISTICS - TIMING PARAMETER MEASUREMENT VOLTAGE LEVELS

Symbol	Rating	Level	Unit
V _{TT}	TTL Threshold	1.5	V
V _{HM}	TTL Rise/Fall Threshold Voltage HIGH	2.0	V
V _{LM}	TTL Rise/Fall Threshold Voltage LOW	0.8	V

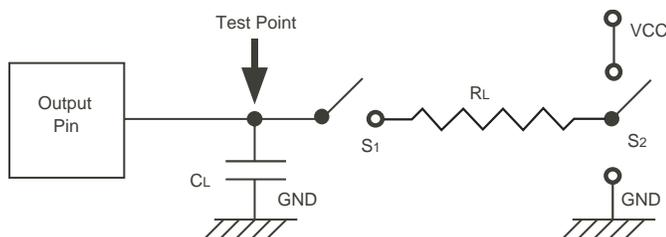

S1 is open circuit except when testing output levels or high impedance states.

S2 is switched to VCC or GND when testing output levels or high impedance states.

5714 drw06

Figure 3. Output Load

AC ELECTRICAL CHARACTERISTICS - FRAME PULSE AND CLK

Symbol	Parameter	Min.	Typ.	Max.	Units
tFPW	Frame Pulse Width (ST-BUS®, GCI) Bit rate = 2.048 Mb/s	26	—	295	ns
tFPS	Frame Pulse Setup time before CLK falling (ST-BUS® or GCI)	10	—	—	ns
tFPH	Frame Pulse Hold Time from CLK falling (ST-BUS® or GCI)	16	—	—	ns
tCP	CLK Period Bit rate = 2.048 Mb/s	190	—	300	ns
tCH	CLK Pulse Width HIGH Bit rate = 2.048 Mb/s	85	—	150	ns
tCL	CLK Pulse Width LOW Bit rate = 2.048 Mb/s	85	—	150	ns
t _r , t _f	Clock Rise/Fall Time	—	—	10	ns

AC ELECTRICAL CHARACTERISTICS⁽¹⁾ — SERIAL STREAM (ST-BUS® and GCI)

Symbol	Parameter	Min.	Typ.	Max.	Units
tsIS	RX Setup Time	5	—	—	ns
tsIH	RX Hold Time	10	—	—	ns
tsOD	TX Delay – Active to Active @ 2.048 Mb/s	—	—	30	ns
tdZ	TX Delay – Active to High-Z @ 2.048 Mb/s	—	—	30	ns
tzD	TX Delay – High-Z to Active @ 2.048 Mb/s	—	—	30	ns
tODE	Output Driver Enable (ODE) Delay @ 2.048 Mb/s	—	—	30	ns

NOTE:

1. High Impedance is measured by pulling to the appropriate rail with R_L (1K), with timing corrected to cancel time taken to discharge C_L (150 pF).

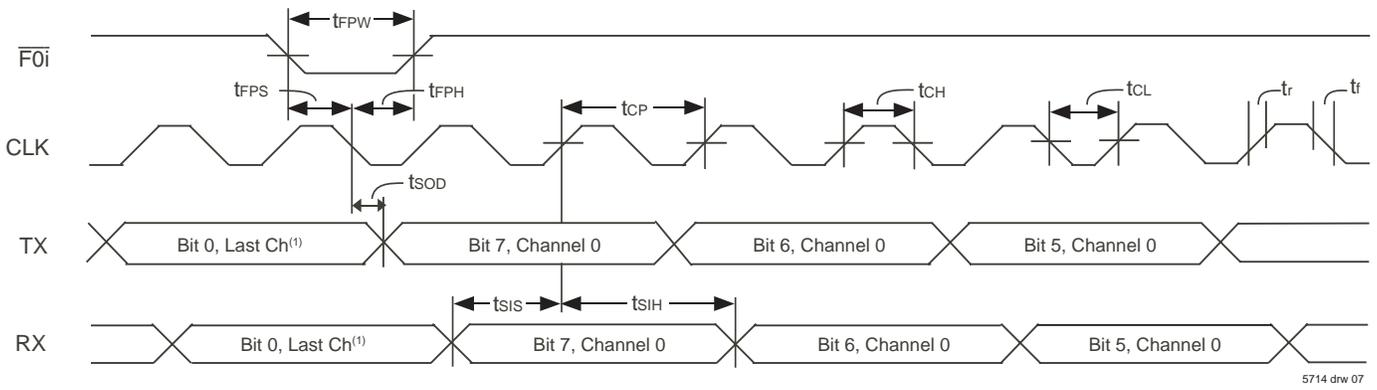

5714 drw 07

NOTE:

1. @ 2.048 Mb/s bit rate, last channel = ch 31,

Figure 4. ST-BUS® Timing

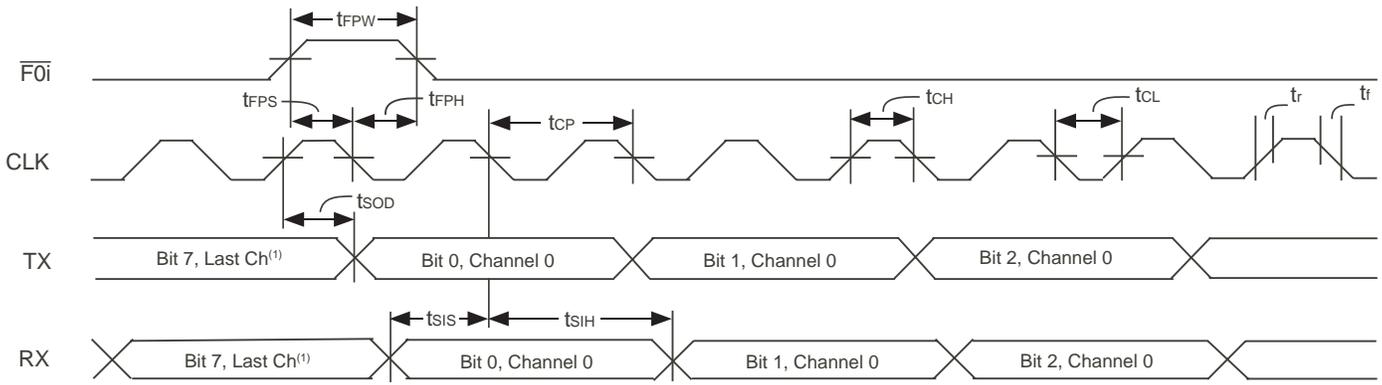

5714 drw 08

NOTE:

1. @ 2.048 Mb/s, last channel = ch 31,

Figure 5. GCI Timing

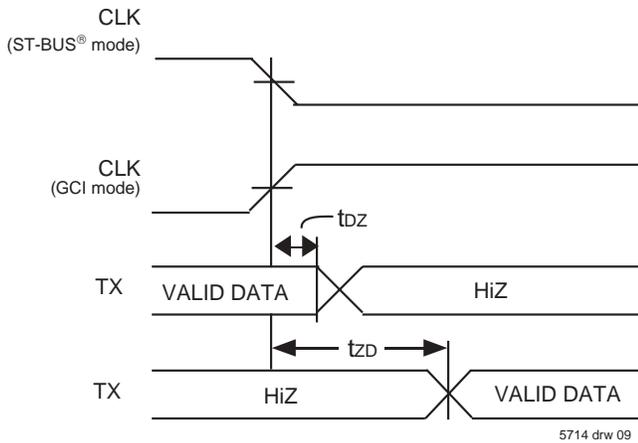

5714 drw 09

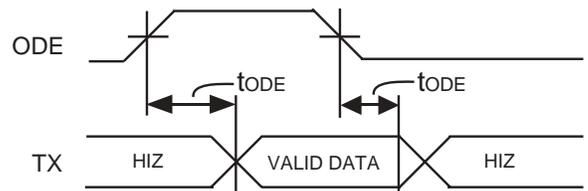

5714 drw10

Figure 6. Serial Output and External Control

Figure 7. Output Driver Enable (ODE)

AC ELECTRICAL CHARACTERISTICS - MICROPROCESSOR INTERFACE TIMING

Symbol	Parameter	Min.	Typ.	Max.	Units
t _{CS}	CS Setup from DS falling	0	—	—	ns
t _{RWS}	R/W Setup from DS falling	3	—	—	ns
t _{ADS}	Address Setup from DS falling	2	—	—	ns
t _{CSH}	CS Hold after DS rising	0	—	—	ns
t _{RWH}	R/W Hold after DS Rising	3	—	—	ns
t _{ADH}	Address Hold after DS Rising	2	—	—	ns
t _{DDR} ⁽¹⁾	Data Setup from DTA LOW on Read	2	—	—	ns
t _{DHR} ^(1,2,3)	Data Hold on Read	10	15	25	ns
t _{DSW}	Data Setup on Write (Fast Write)	10	—	—	ns
t _{SWD}	Valid Data Delay on Write (Slow Write)	-	—	0	ns
t _{DHW}	Data Hold on Write	5	—	—	ns
t _{AKD} ⁽¹⁾	Acknowledgment Delay: Reading/Writing Registers Reading/Writing Memory			30 345	ns ns
t _{AKH} ^(1,2,3)	Acknowledgment Hold Time	—	—	20	ns
t _{DSS} ⁽⁴⁾	Data Strobe Setup Time	2	—	—	ns

NOTES:

1. CL= 150pF
2. RL = 1K
3. High Impedance is measured by pulling to the appropriate rail with R_L, with timing corrected to cancel time taken to discharge C_L.
4. To achieve one clock cycle fast memory access, this setup time, t_{DSS} should be met. Otherwise, memory access operation is determined by t_{AKD}, which in worst case is 345 ns.

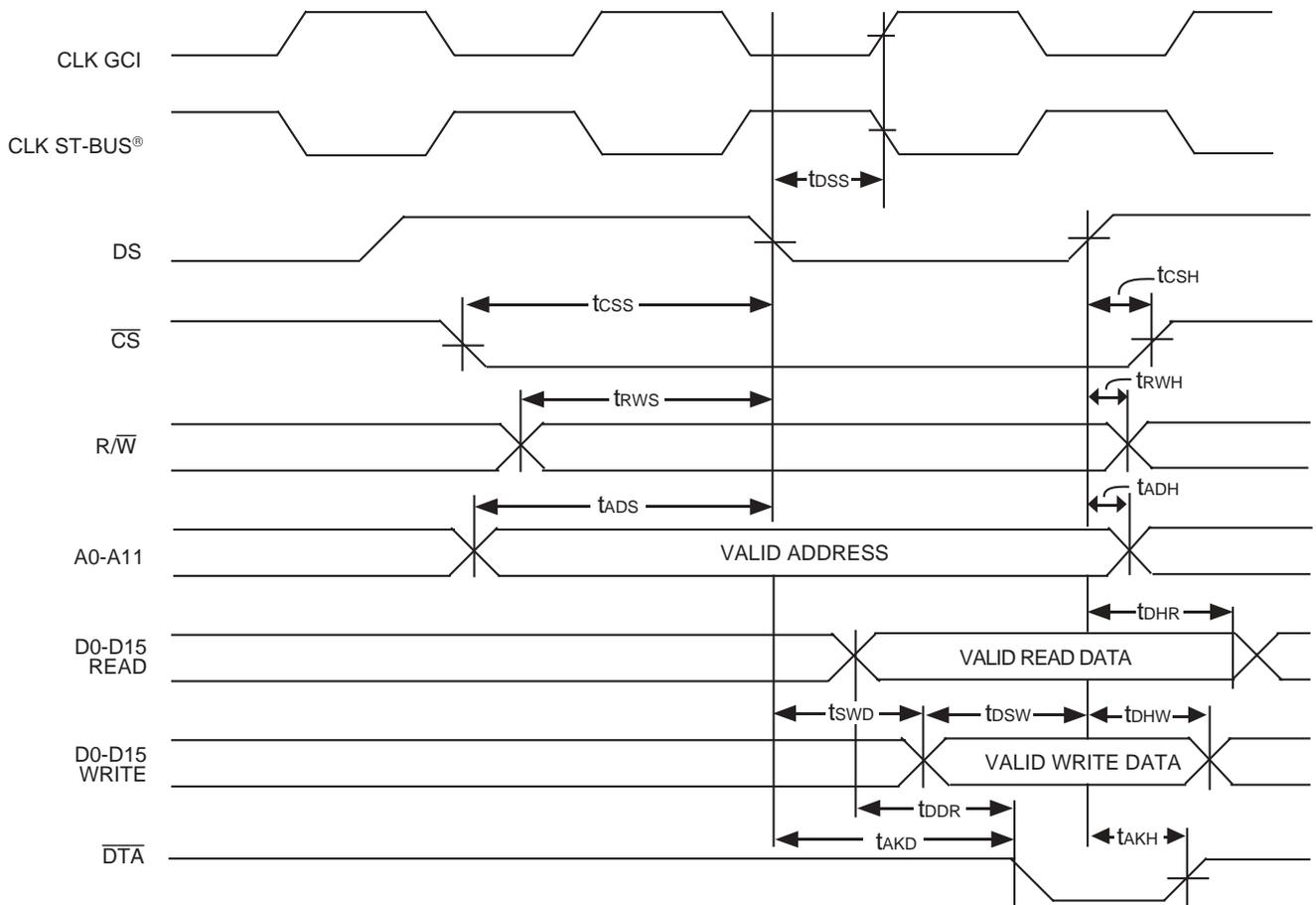

5714 drw 11

Figure 8. Motorola Non-Multiplexed Bus Timing

ORDERING INFORMATION

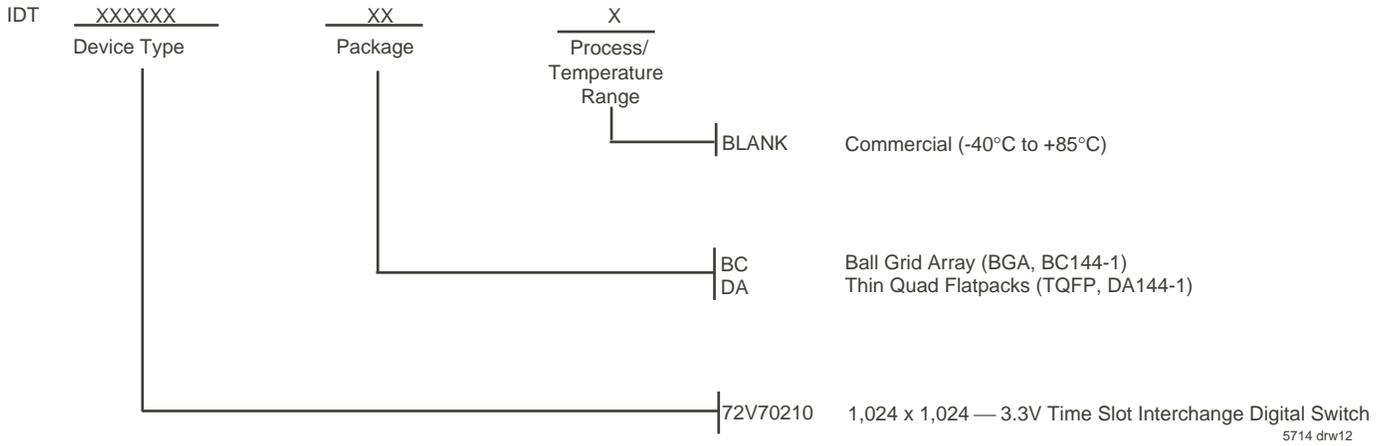

DATASHEET DOCUMENT HISTORY

5/05/2000	pg. 1
6/08/2000	pgs. 1, 2, 3 and 18.
8/30/2000	pgs. 2, 4, 5, 7, 9, 13 and 17.
01/24/2001	pg. 13
10/22/2001	pg. 1
1/04/2002	pgs. 1 and 14.
1/11/2005	pgs. 2, 3 and 4.



CORPORATE HEADQUARTERS
 2975 Stender Way
 Santa Clara, CA 95054

for SALES:
 800-345-7015 or 408-727-6116
 fax: 408-492-8649
 www.idt.com

for Tech Support:
 408-330-1552
 email: TELECOMhelp@idt.com