

| DATE     | REV | ECN  | APP'D. BY |
|----------|-----|------|-----------|
| 00-00-00 | A0  | -    | -         |
| 03-09-04 | A1  | 3651 | JMB       |
| 1-19-06  | A2  | 7441 | JM        |

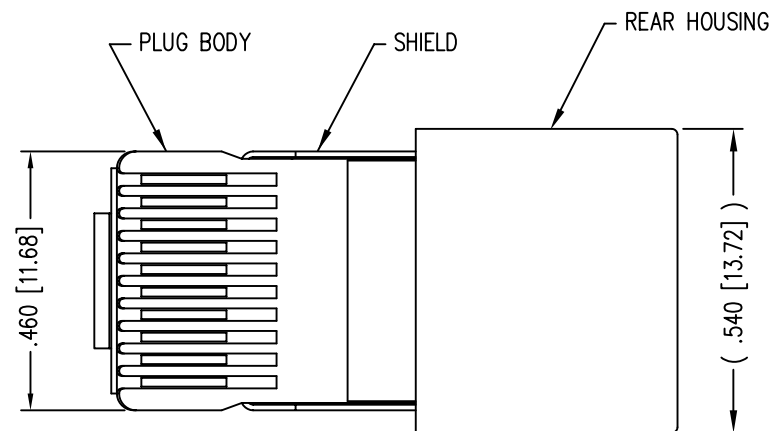

( SHOWN ASSEMBLED )

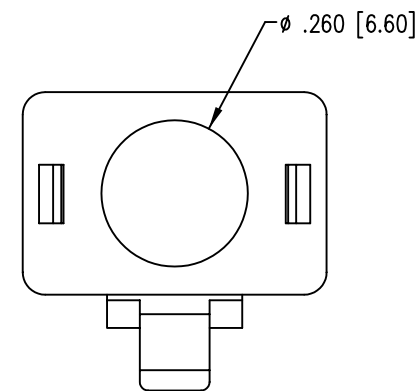
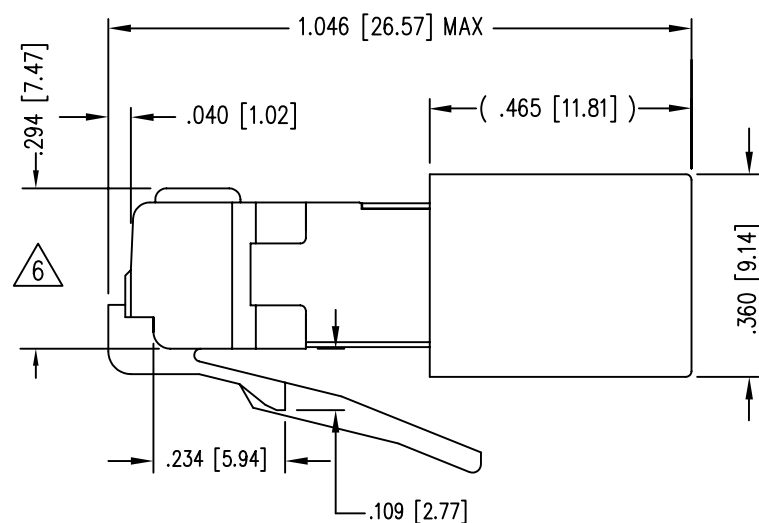
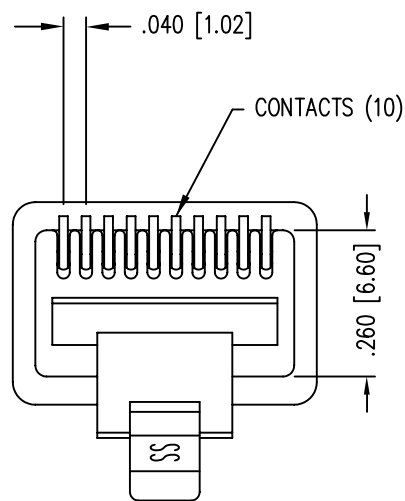

NOTES:

- 1- PLUG KIT CONSISTS OF :  
PRE-INSERTED PLUG HOUSING & SHIELD  
MANAGEMENT BAR  
FERRULE
- 2- MATERIALS :  
FRONT HOUSING PLASTIC : CLEAR POLYCARBONATE, UL 94-V0  
MANAGEMENT BAR : CLEAR POLYCARBONATE, UL 94-V0  
SHIELD : TIN PLATED BRASS  
CONTACTS : PHOSPHOR BRONZE, SELECTIVE GOLD PLATING  
FERRULE : TIN PLATED BRASS
- 3- CONTACTS TERMINATE STRANDED CONDUCTORS UP TO .037 [0.94] OUTSIDE DIAMETER OF INSULATION.
- 4- FOR PLUG SPECIFICATION SEE PR026-01.
- 5- TOLERANCES COMPLY WITH F.C.C. DIMENSION REQUIREMENTS.
- △ TERMINATED PLUG HEIGHT: .237 [6.02] ±.005 [0.13]

|         |                                   |                    |
|---------|-----------------------------------|--------------------|
| BULK    | 50 MICRO-INCHES [1.27um]          | 940-SP-361010-A161 |
| PACKAGE | CONTACT PLATING<br>IN MATING AREA | PART NUMBER        |

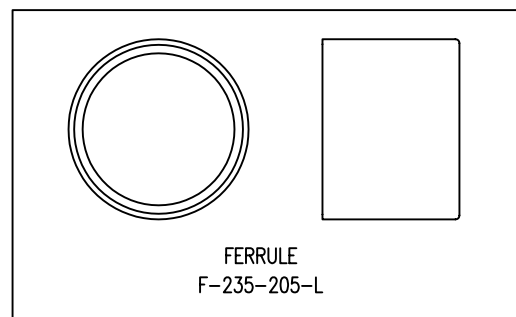

FERRULE  
F-235-205-L

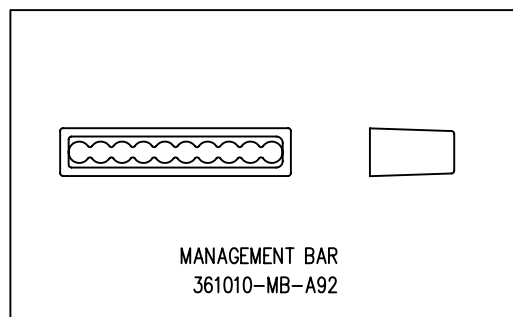

MANAGEMENT BAR  
361010-MB-A92

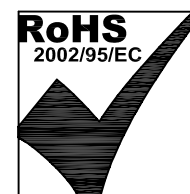

THIRD ANGLE PROJECTION

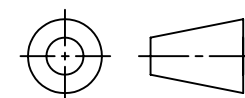

DO NOT SCALE DRAWING  
DRAWING IS SUBJECT TO  
CHANGE WITHOUT NOTICE

DIMENSIONS: INCHES [METRIC]

UNLESS OTHERWISE SPECIFIED  
TOLERANCES ARE ±.005 [0.13]  
ANGLES ARE ± 1°

SHEET NO. 1 OF 1

# Bel Stewart Connector

11118 Susquehanna Trail South  
Glen Rock, PA 17327-9199  
(717) 235-7512 Fax: (717) 235-7954 <http://www.stewartconnector.com>

TITLE: 10 X 10 SHIELDED PLUG

THIS DRAWING AND THE SUBJECT MATTER SHOWN THEREON ARE CONFIDENTIAL AND THE PROPRIETARY PROPERTY OF BEL STEWART CONNECTOR AND SHALL NOT BE REPRODUCED, COPIED, OR USED IN ANY MANNER WITHOUT PRIOR WRITTEN CONSENT OF BEL STEWART CONNECTOR. THE SUBJECT MATTER MAY BE PATENTED OR A PATENT MAY BE PENDING.

DRN BY: RS DATE 8-16-95

APPD BY: JW DATE 8-16-95

DWG NO. CT310107 REV. A2