

DATE	REV	ECN	APP'D. BY
5-8-06	C1	7618	TRM

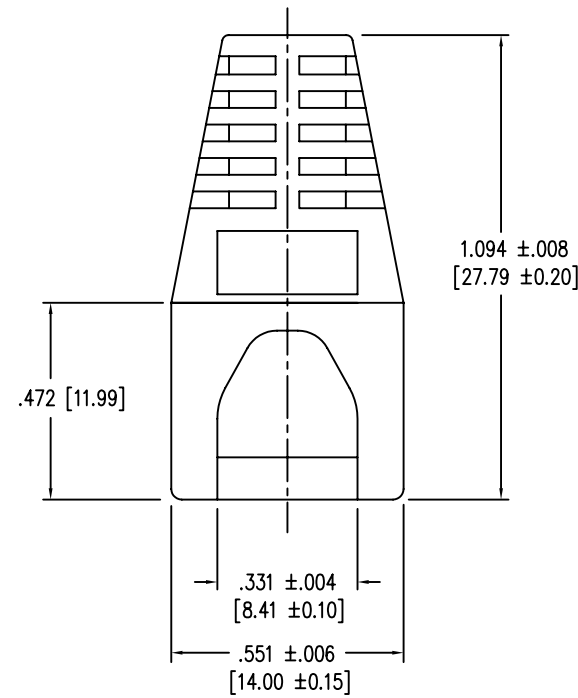
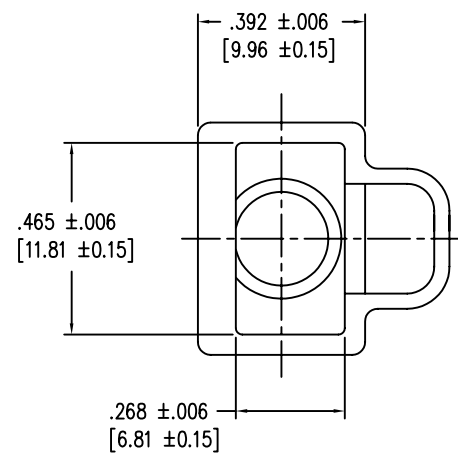
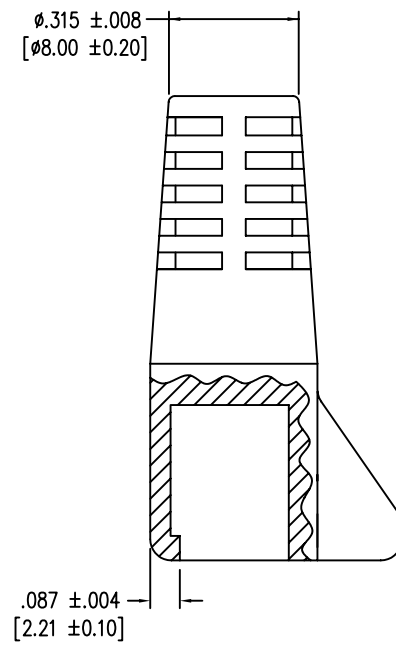
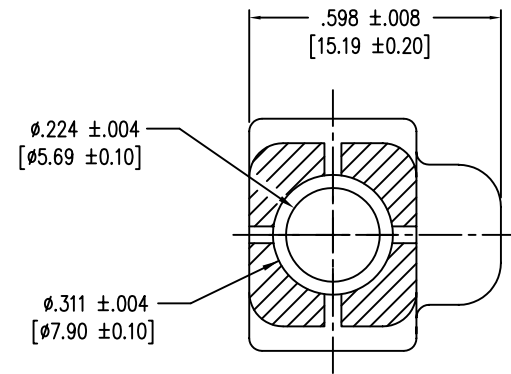

PART NUMBER	COLOR
450-011	BLACK
450-012	DARK GREY
450-013	YELLOW
450-014	GREEN
450-015	BLUE
450-016	LIGHT GREY
450-017	PURPLE
450-018	WHITE
450-019	RED

NOTES:  
 1. CONNECTOR MATERIALS:  
 HOUSING: THERMOPLASTIC UL94 V-0

THIRD ANGLE PROJECTION

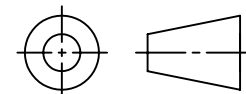

DO NOT SCALE DRAWING  
 DRAWING IS SUBJECT TO  
 CHANGE WITHOUT NOTICE

DIMENSIONS: INCHES [METRIC]

UNLESS OTHERWISE SPECIFIED  
 TOLERANCES ARE ±.005 [0.13]  
 ANGLES ARE ± 1°

SHEET NO. 1 OF 1

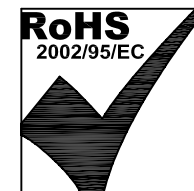

# Bel Stewart Connector

11118 Susquehanna Trail South  
 Glen Rock, PA 17327-9199  
 (717) 235-7512 Fax: (717) 235-7954 <http://www.stewartconnector.com>

TITLE: EXTERNAL STRAIN RELIEF BOOT

THIS DRAWING AND THE SUBJECT MATTER SHOWN THEREON ARE CONFIDENTIAL AND THE PROPRIETARY PROPERTY OF BEL STEWART CONNECTOR AND SHALL NOT BE REPRODUCED, COPIED, OR USED IN ANY MANNER WITHOUT PRIOR WRITTEN CONSENT OF BEL STEWART CONNECTOR. THE SUBJECT MATTER MAY BE PATENTED OR A PATENT MAY BE PENDING.

DRN BY:	DAB	DATE	9/9/03
APPD BY:	RGC	DATE	9/12/03
DWG NO.	CT999002	REV.	C1

REV. 6/3/05