

Sens-A-Coil Temperature Sensor

Features:

- Designed for HVAC and refrigeration applications
- Available to fit standard return bend on 3/8" coil tubing
- Easy installation - just snaps on
- Excellent thermal tracking
- Cost efficient design
- Sturdy construction

Description:

HVAC and refrigeration engineers have searched for years for a cost effective sensor capable of monitoring the refrigerant temperature in condenser and evaporator coils. In these applications, the only suitable place to mount the sensor is on the coil return bend, which makes sensor attachment a very difficult design problem.

In the past, a number of "thermowell" or strap-on designs have been used but they were either difficult and time-consuming to install or they did not accurately sense the refrigerant temperature. The SS&C Sens-A-Coil solves the problem by integrating a fast response thermistor element into a plastic overmolded copper clip specially designed to snap onto 3/8" return bends. Because the sensor is housed in a small bulb which is attached to the copper clips, the Sens-A-Coil maximizes sensing surface area which enables the sensing element to quickly react to any changes in the refrigerant temperature. And since no tools are needed to install the Sens-A-Coil, both time and money can be saved in production and field service environments. The Sens-A-Coil is also well suited for use in HVAC diagnostic equipment and tools.

This **patented** (Patent #6,814,486 B2) design from SS&C is the solution for sensing condenser and evaporator return bend temperatures. The Sens-A-Coil comes standard with 10ft. of AWG#22 PVC jacketed cable. Please contact the factory for specific design or application information or the availability of options.



Sens-A-Coil Thermistor Sensor

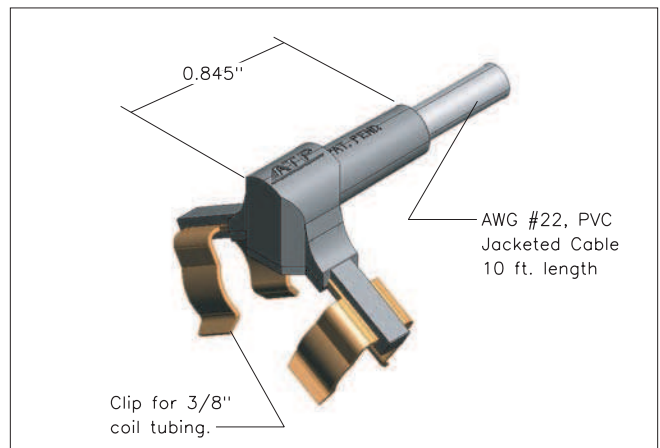
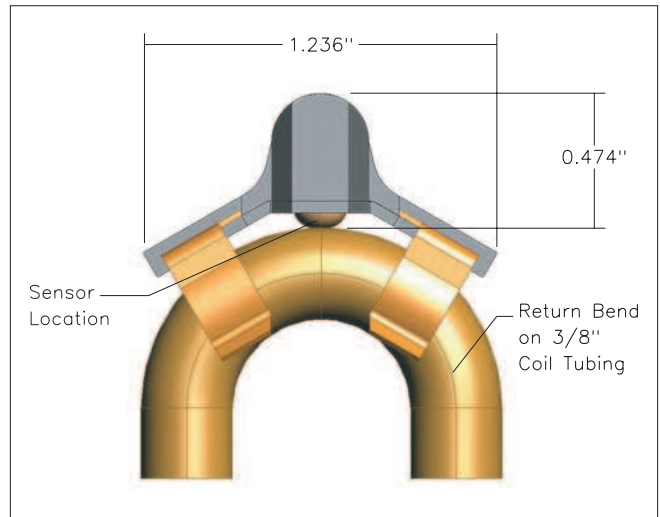

Ordering Information

SS&C Part Number	R ₂₅ (Ω)	Material Curve
D5003MC22P0	5,000	Z
D1004MC22P0	10,000	Z

Standard resistance tolerance is ±2% at 25°C. Resistance versus temperature information for material curve Z can be found on page 59.