

Current Transducer HTA 100 .. 1000-S

For the electronic measurement of currents: DC, AC, pulsed..., with galvanic isolation between the primary circuit (high power) and the secondary circuit (electronic circuit).

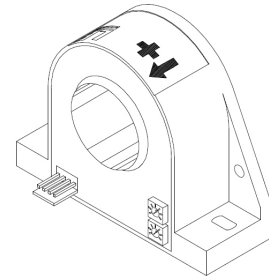

$I_{PN} = 100 \dots 1000 \text{ A}$



Electrical data

Type	Primary nominal current rms I_{PN} (A)	Primary current, measuring range I_{PM} (A)	RoHS since date code
HTA 100-S	100	± 300	46179
HTA 200-S	200	± 600	46170
HTA 300-S	300	± 900	46097
HTA 400-S	400	± 1000	46100
HTA 500-S	500	± 1000	46083
HTA 600-S	600	± 1000	46222
HTA 1000-S	1000	± 1000	46118
V_{OUT}	Output voltage (Analog) @ $\pm I_{PN}$	± 4	V
R_L	Load resistance $T_A = 0 \dots +70^\circ\text{C}$ $T_A = -25 \dots +85^\circ\text{C}$	> 1 > 3	k Ω k Ω
V_C	Supply voltage ($\pm 5\%$)	± 15	V
I_C	Current consumption	< 25	mA
R_{IS}	Isolation resistance @ $500 V_{DC}$	> 500	M Ω

Accuracy - Dynamic performance data

X	Accuracy ¹⁾ @ I_{PN} , $T_A = 25^\circ\text{C}$, @ $\pm 15 \text{ V}$	± 1	%
ϵ_L	Linearity error ¹⁾ ($0 \dots \pm I_{PN}$)	± 0.5	%
V_{OE}	Electrical offset voltage, @ $I_P = 0$, $T_A = 25^\circ\text{C}$	$< \pm 10$	mV
V_{OH}	Hysteresis offset voltage @ $I_P = 0$, after an excursion of $3 \times I_{PN}$	$< \pm 10$	mV
TCV_{OE}	Temperature coefficient of V_{OE} $T_A = -25 \dots +85^\circ\text{C}$	$< \pm 1$	mV/K
TCV_{OUT}	Temperature coefficient of V_{OUT} $T_A = -25 \dots +85^\circ\text{C}$	$< \pm 0.05$	%/K
t_r	Response time to 90 % of I_{PN} step	< 3	μs
di/dt	di/dt accurately followed	> 50	A/ μs
BW	Frequency bandwidth (-3 dB) ²⁾	DC .. 50	kHz

General data

T_A	Ambient operating temperature	$-25 \dots +85$	$^\circ\text{C}$
T_S	Ambient storage temperature	$-25 \dots +85$	$^\circ\text{C}$
m	Mass	230	g
	Standards	Safety EMC	EN 50178(1994) EN 50082-2(1992) EN 50081-1(1992)
	Deviation in output when tested to EN 61000-4-3	< 25	% of I_{PN}

Notes: ¹⁾ Excludes the electrical offset

²⁾ Refer to derating curves in the technical file to avoid excessive core heating at high frequency.

Features

- Open loop transducer using Hall effect
- Panel mounting-Horizontal or Vertical
- Insulated plastic case recognized according to UL 94-V0

Advantages

- Very good linearity
- Very good accuracy
- Low temperature drift
- Wide frequency bandwidth
- Very low insertion losses
- High immunity to external interference
- Current overload capability
- Low power consumption
- Wide dynamic range, 100 to 1000 A in one package.

Applications

- AC variable speed drives and servo motor drives
- Static converters for DC motor drives
- Battery supplied applications
- Uninterruptible Power Supplies (UPS)
- Switched Mode Power Supplies (SMPS)
- Power supplies for welding applications.

Application domain

- Industrial.

Current Transducer HTA 100 .. 1000-S

Isolation characteristics

V_d	Rms voltage for AC isolation test, 50 Hz, 1 min	4.0	kV
\hat{V}_w	Impulse withstand voltage 1.2/50 μ s	> 7.3	kV
		Min	
dCp	Creepage distance	7.2	mm
dCI	Clearance distance	7.2	mm
CTI	Comparative Tracking Index (group IIIa)	600	

Applications examples

According to **EN 50178** and **IEC 61010-1** standards and following conditions:

- Over voltage category III
- Pollution degree PD2
- Non-uniform field

	EN 50178	IEC 61010-1
dCp, dCI, \hat{V}_w	Rated isolation voltage	Nominal voltage
Single isolation	600 V	600 V
Reinforced isolation	300 V	300 V

Safety



This transducer must be used in electric/electronic equipment with respect to applicable standards and safety requirements in accordance with the manufacturer's operating instructions.



Caution, risk of electrical shock

When operating the transducer, certain parts of the module can carry hazardous voltage (eg. primary busbar, power supply).

Ignoring this warning can lead to injury and/or cause serious damage.

This transducer is a build-in device, whose conducting parts must be inaccessible after installation.

A protective housing or additional shield could be used.

Main supply must be able to be disconnected.

Dimensions HTA 100 .. 1000-S (in mm. 1 mm = 0.0394 inch)

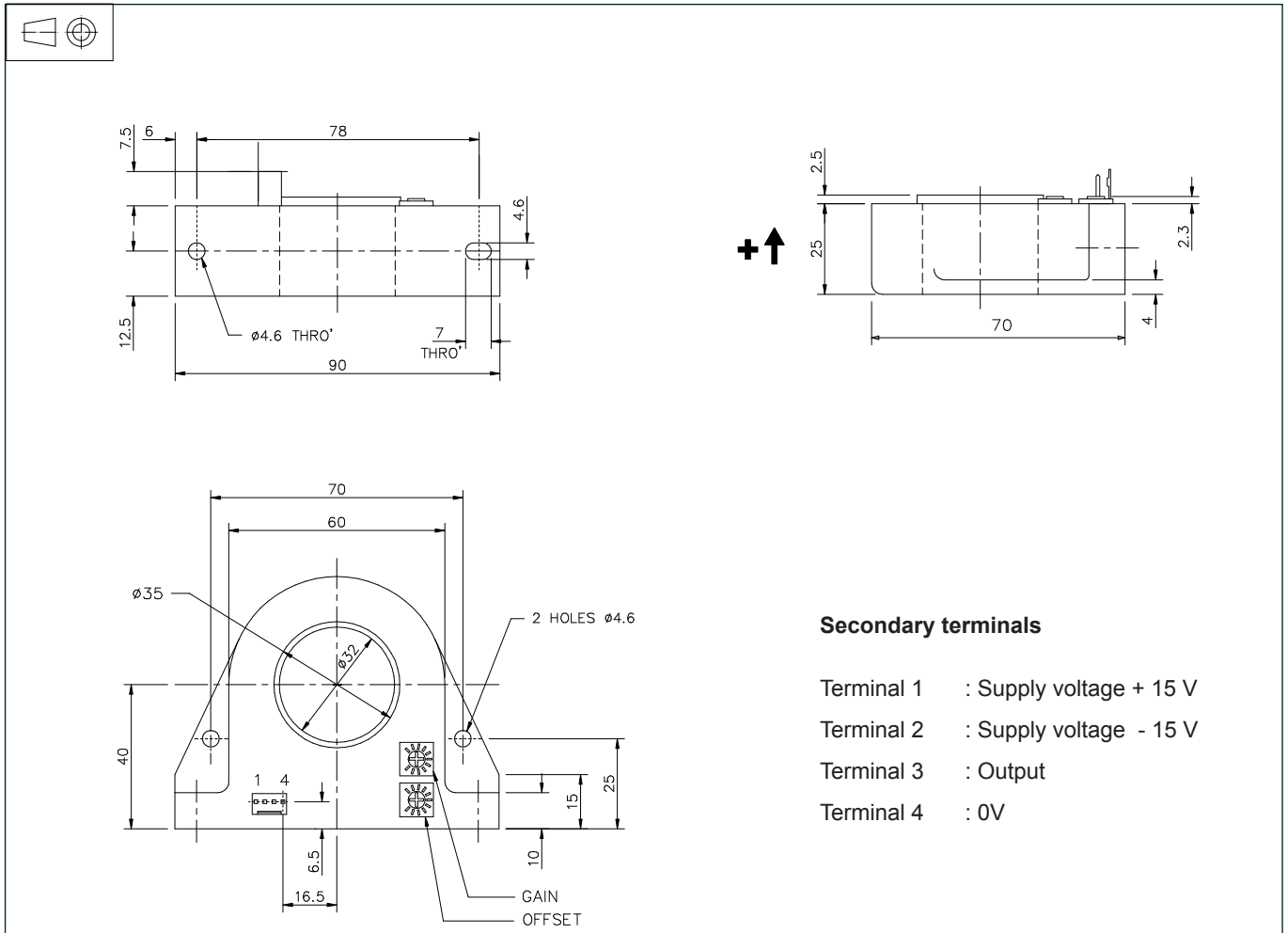

Mechanical characteristics

- General tolerance ± 0.5 mm
- Primary through-hole $\phi 32$ mm
- Connection of secondary Molex 5045-04A

Remarks

- V_{OUT} is positive when I_p flows in the direction of the arrow.
- Temperature of the primary conductor should not exceed 90°C .
- This is a standard model. For different versions (supply voltages, secondary connections, unidirectional measurements, operating temperatures, etc..) please contact us.