

DATE	REV	ECN	APP'D. BY
3-03-09	A0	-	TS

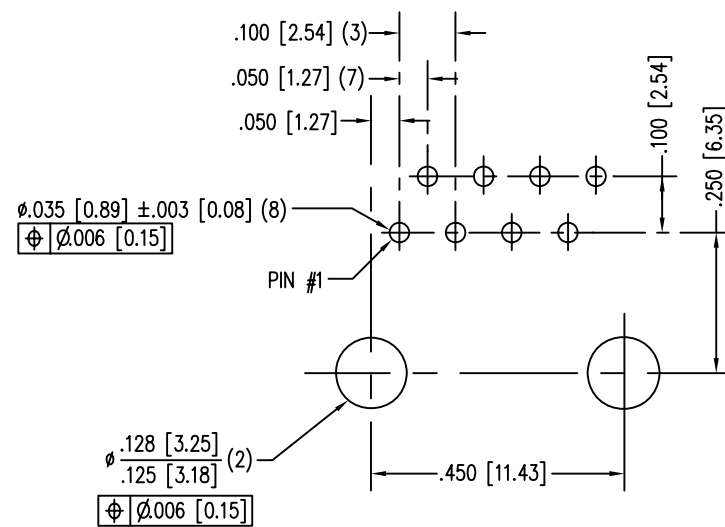
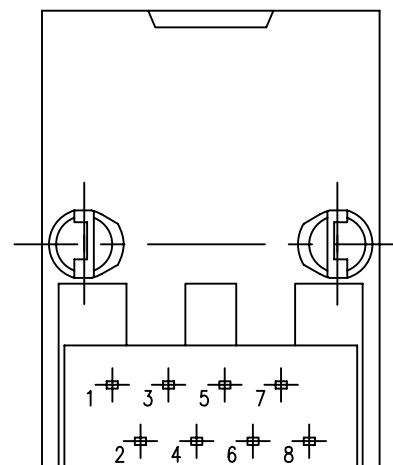
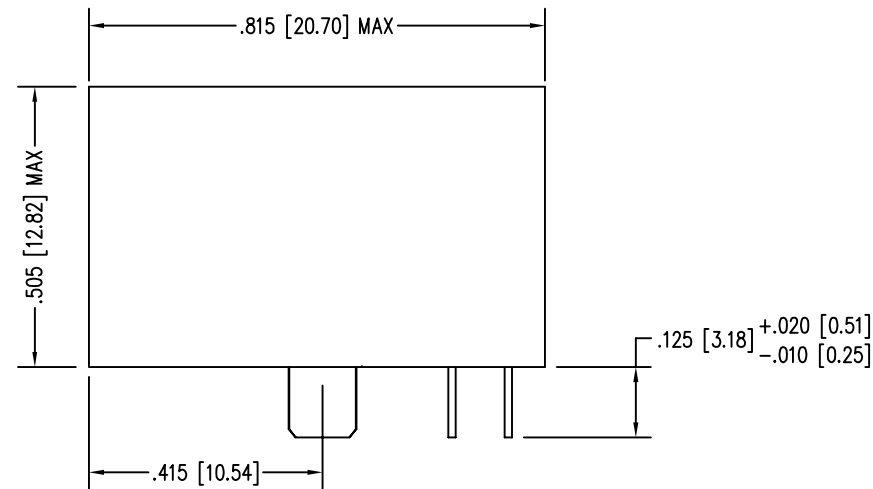
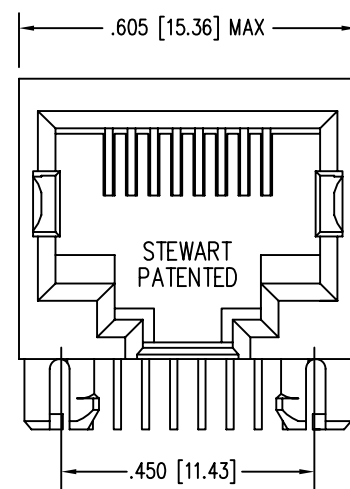

P.C.B. RECOMMENDED HOLE LAYOUT
SEEN FROM COMPONENT SIDE
ALL CENTERLINE DIMENSIONS ARE BASIC.

NOTES:

- CONNECTOR MATERIALS:
HOUSING: THERMOPLASTIC UL94 V-0
CONTACTS: COPPER ALLOY
CONTACT PLATING: SELECTIVE GOLD IN CONTACT AREA
SEE CHART FOR PART NUMBER
- FOR PRODUCT SPECIFICATIONS SEE PR030-01.
- RATED AT MAX. 260°C FOR MAX. 10 SECS.
- DIMENSIONS AND TOLERANCES COMPLY WITH FCC/CFR 47, PART 68.

30 MICRO-INCHES [0.76um]	SS64800-008G
CONTACT PLATING IN MATING AREA	PART NUMBER

EPP-918A TYPICAL PROPERTIES		
PROPERTY	VALUE	TEST METHOD
COLOR	LIGHT YELLOW	
SPECIFIC GRAVITY	0.75	ASTM D-792
DENSITY	0.89	ASTM D-1480
OPERATING TEMPERATURE RANGE	-40°C TO 85°C	
WATER SOLUBILITY	NEGLIGIBLE	

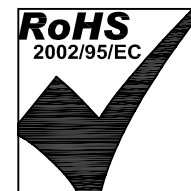

THIRD ANGLE PROJECTION

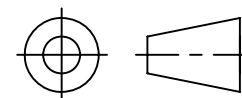

DO NOT SCALE DRAWING
DRAWING IS SUBJECT TO
CHANGE WITHOUT NOTICE

DIMENSIONS: INCHES [METRIC]

UNLESS OTHERWISE SPECIFIED
TOLERANCES ARE ±.005 [0.13]
ANGLES ARE ± 1°

SHEET NO. 1 OF 1

Bel Stewart Connector

11118 Susquehanna Trail South
Glen Rock, PA 17327-9199
(717) 235-7512 Fax: (717) 235-7954 <http://www.stewartconnector.com>

TITLE: 8 CONTACT, 8 POSITION JACK, NON-FLANGE
CONTAINS EPP-918A, HIGH TEMPERATURE APPLICATION

THIS DRAWING AND THE SUBJECT MATTER SHOWN THEREON
ARE CONFIDENTIAL AND THE PROPRIETARY PROPERTY OF
BEL STEWART CONNECTOR AND SHALL NOT BE REPRODUCED,
COPIED, OR USED IN ANY MANNER WITHOUT PRIOR WRITTEN
CONSENT OF BEL STEWART CONNECTOR. THE SUBJECT
MATTER MAY BE PATENTED OR A PATENT MAY BE PENDING.

DRN BY: TS	DATE 3-03-09
APPD BY: TRM	DATE 3-03-09
DWG NO. CT640041G	REV. A0