

DATE	REV	ECN	APP'D. BY
12-19-08	A0	-	-
8-10-11	A1	9245	TRM

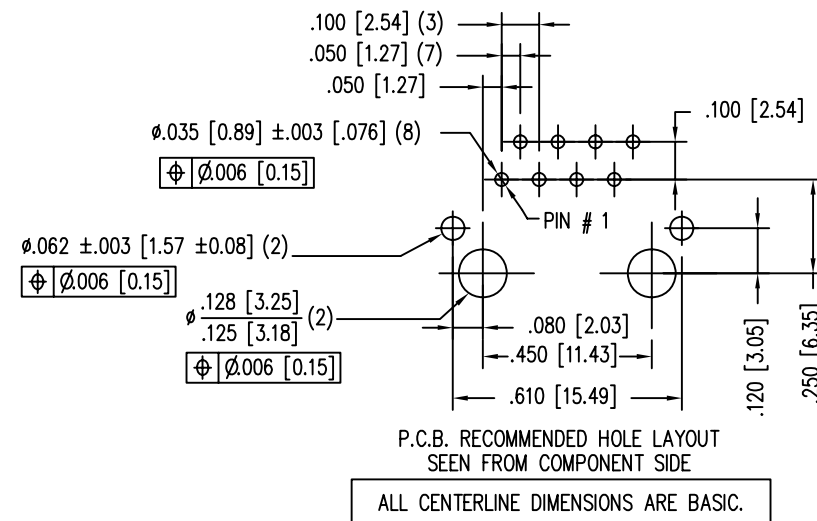
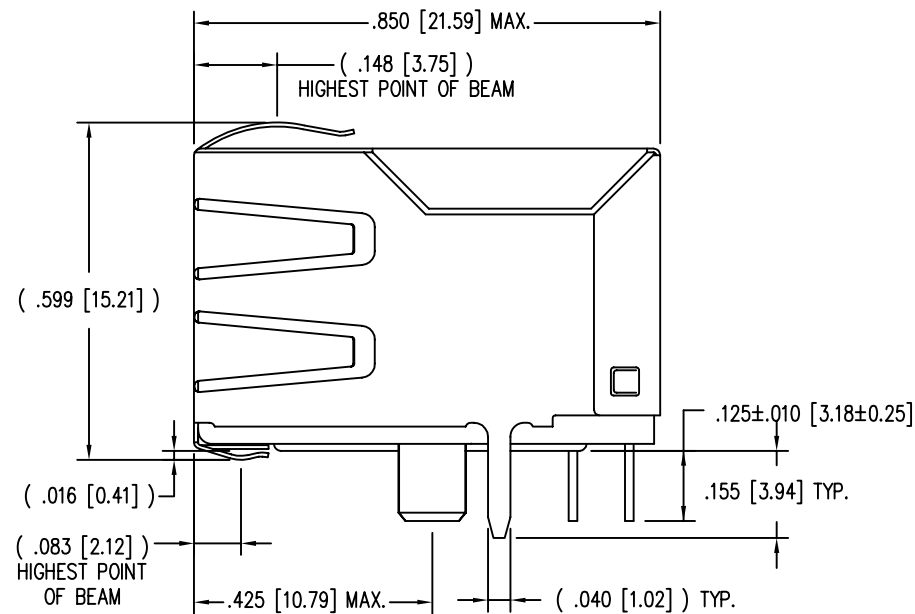
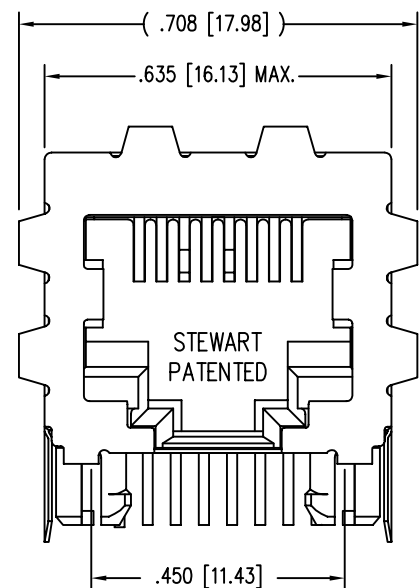

NOTES:

- CONNECTOR MATERIALS:
HOUSING: THERMOPLASTIC UL94 V-0
CONTACTS/SHIELD: COPPER ALLOY
SHIELD PLATING: NICKEL OR "REFLOW" TIN
CONTACT PLATING: SELECTIVE GOLD OR EQUIVALENT IN THE CONTACT AREA
SEE CHART FOR PART NUMBER
- FOR PRODUCT SPECIFICATIONS SEE PR030-01.
- DIMENSIONS AND TOLERANCES COMPLY WITH TIA-1096 STANDARD.
- THE SUGGESTED PANEL OPENING IS INTENDED TO GIVE USER THE ABILITY TO HAVE REASONABLE JACK/PANEL CLEARANCES, YET MAINTAIN GROUNDING CAPABILITY. THESE VARIABLES CAN BE ADJUSTED IN EITHER DIRECTION BUT MAY CARRY SOME CONSEQUENCES IN THE FORM OF LOWER MATING FORCES OR TIGHTER ASSEMBLY TOLERANCES.
- DIELECTRIC WITHSTANDING VOLTAGE (CONTACT TO SHIELD) : 2250VDC
- DESIGNED FOR CATEGORY 5/5e APPLICATIONS.

B

B

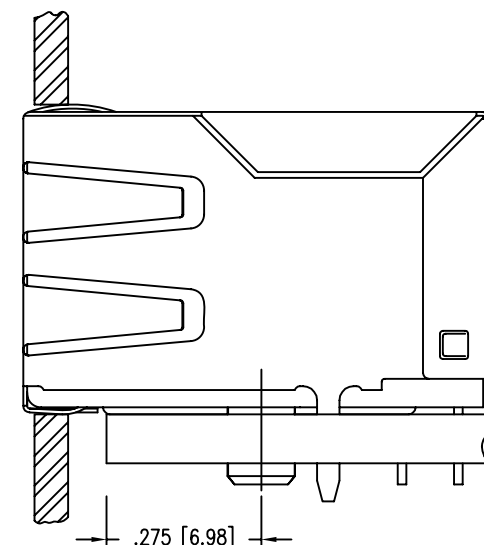
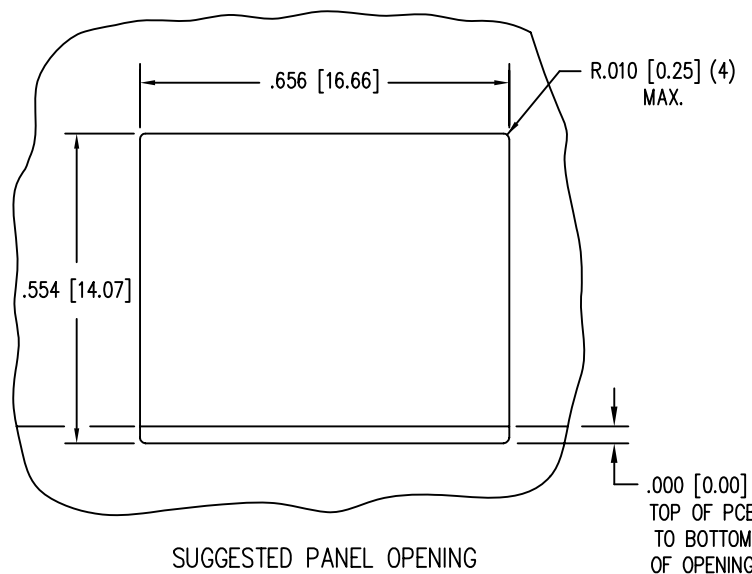
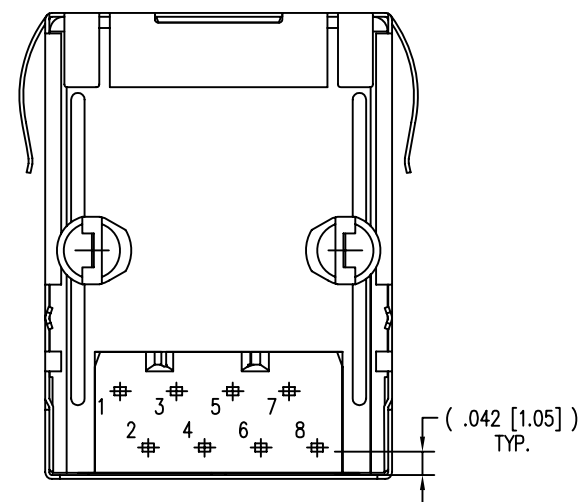

A

A

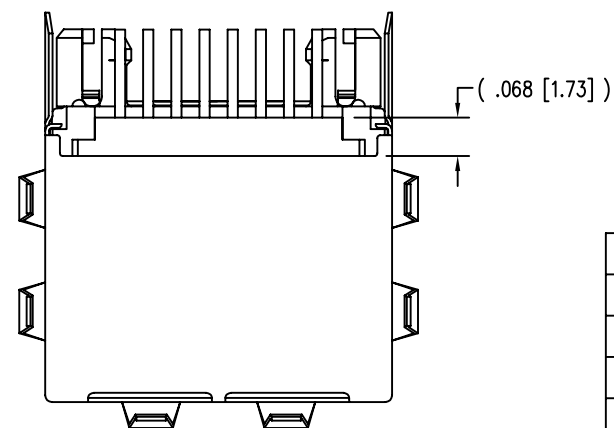

50 MICRO-INCHES [1.27um]	SS71800-019G
CONTACT PLATING IN MATING AREA	PART NUMBER

EPP-918A TYPICAL PROPERTIES		
PROPERTY	VALUE	TEST METHOD
COLOR	LIGHT YELLOW	
SPECIFIC GRAVITY	0.75	ASTM D-792
DENSITY	0.89	ASTM D-1480
OPERATING TEMPERATURE RANGE	-40°C TO 85°C	
WATER SOLUBILITY	NEGLECTIBLE	

THIRD ANGLE PROJECTION

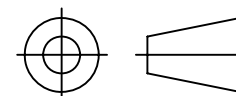

DO NOT SCALE DRAWING
DRAWING IS SUBJECT TO CHANGE WITHOUT NOTICE

DIMENSIONS: INCHES [METRIC]

UNLESS OTHERWISE SPECIFIED TOLERANCES ARE ±.005 [0.13] ANGLES ARE ± 1°

SHEET NO. 1 OF 1

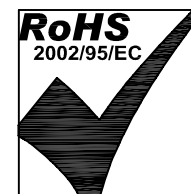

Bel Stewart Connector

11118 Susquehanna Trail South
Glen Rock, PA 17327-9199
(717) 235-7512 Fax: (717) 235-7954 <http://www.stewartconnector.com>

TITLE: 8 CONT, 8 POS, SHLD CAT 5/5e JACK EMI-RFI ONE PC SHLD ESD GROUNDED, CONTAINS EPP-918A

THIS DRAWING AND THE SUBJECT MATTER SHOWN THEREON ARE CONFIDENTIAL AND THE PROPRIETARY PROPERTY OF OF STEWART AND SHALL NOT BE REPRODUCED, COPIED OR USED IN ANY MANNER WITHOUT PRIOR WRITTEN CONSENT OF STEWART. THE SUBJECT MATTER MAY BE PATENTED OR A PATENT MAY BE PENDING.

DRN BY:	TRM	DATE	12-19-08
APPD BY:	DHG	DATE	12-19-08
DWG NO.	CT710114G	REV.	A1