

DATE	REV	ECN	APP'D. BY
2-22-06	B5	7515	JM
12-14-10	B6	9103	TRM
1-19-10	B7	9124	SMN

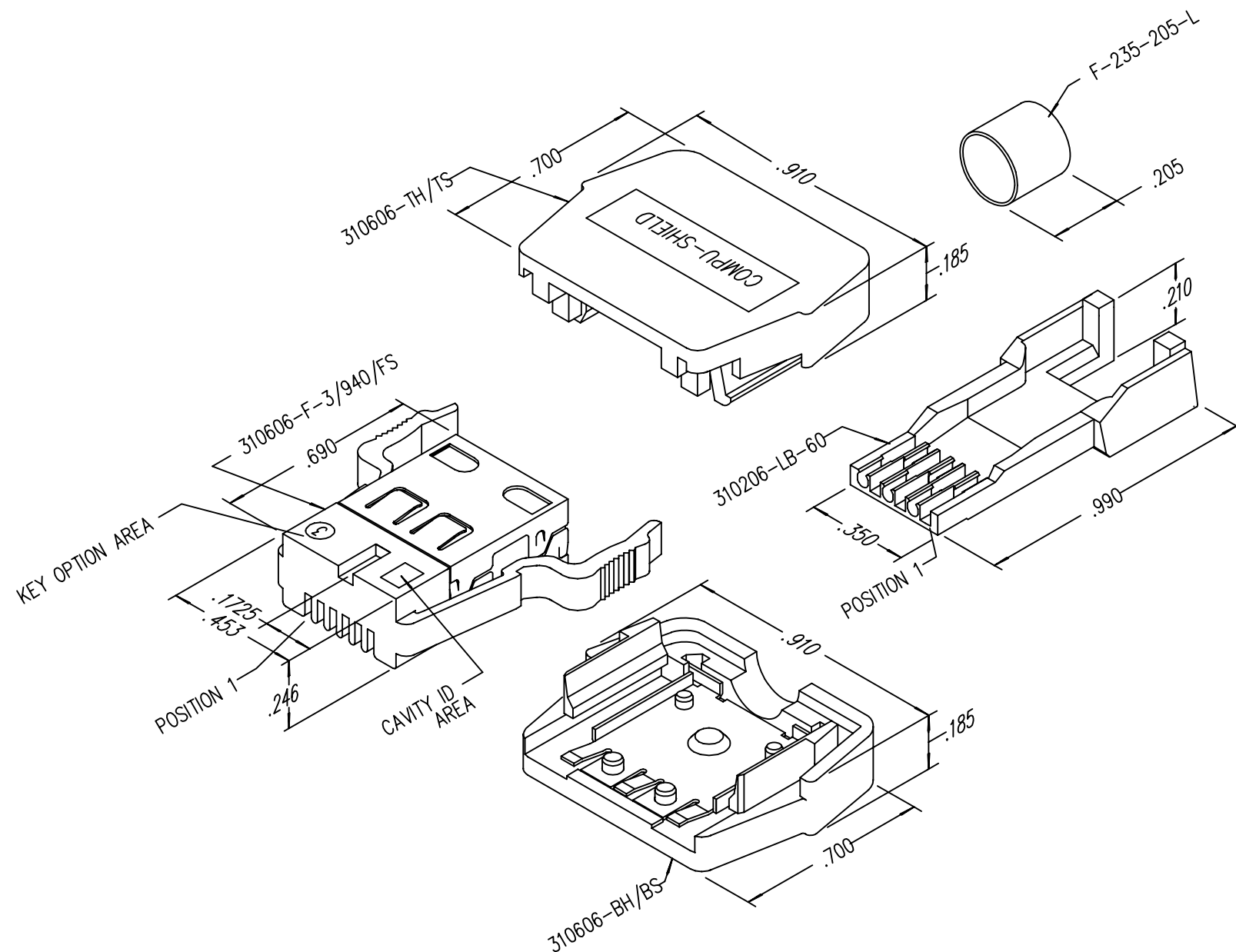

NOTES:

- PLUG MATERIALS:  
 TOP/BOTTOM HOUSING: PC UL94 V-0 COLOR: BLACK  
 FRONT PLASTIC: PC UL94 V-0 COLOR: ORANGE  
 LOAD BAR: PC UL94 V-0 COLOR: CLEAR  
 CONTACTS/SHIELD: COPPER ALLOY  
 SHIELD PLATING: TIN  
 FERRULE PLATING: NICKEL OR TIN  
 CONTACT PLATING: SELECTIVE GOLD IN CONTACT AREA  
 SEE CHART FOR PART NUMBER
- CONTACTS TERMINATE SOLID OR STRANDED CONDUCTORS  
 UP TO .064" OUTSIDE DIAMETER ON POSITION #1 & #6 CONDUCTORS,  
 UP TO .021" OUTSIDE DIAMETER ON POSITION #2 & #5 CONDUCTORS,  
 AND UP TO .042" OUTSIDE DIAMETER ON POSITION #3 & #4 CONDUCTORS
- DIMENSIONS AND TOLERANCES COMPLY WITH TIA-1096 STANDARD.
- HOUSING WILL ACCEPT CABLE UP TO .220" OUTSIDE DIAMETER OF JACKET
- FOR PRODUCT SPECIFICATIONS SEE PR026-01
- TERMINATED PLUG HEIGHT .234±.002 ON CABLE

50 MICRO-INCHES [1.27um]	SS-310606-3-60
CONTACT PLATING IN MATING AREA	PART NUMBER

THIRD ANGLE PROJECTION

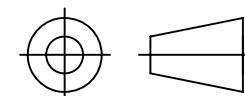

DO NOT SCALE DRAWING  
 DRAWING IS SUBJECT TO  
 CHANGE WITHOUT NOTICE

DIMENSIONS: INCHES [METRIC]

UNLESS OTHERWISE SPECIFIED  
 TOLERANCES ARE ±.005 [0.13]  
 ANGLES ARE ± 1°

SHEET NO. 1 OF 1



# Bel Stewart Connector

11118 Susquehanna Trail South  
 Glen Rock, PA 17327-9199  
 (717) 235-7512 Fax: (717) 235-7954 <http://www.stewartconnector.com>

TITLE: COMPU-SHIELD PLUG

THIS DRAWING AND THE SUBJECT MATTER SHOWN THEREON  
 ARE CONFIDENTIAL AND THE PROPRIETARY PROPERTY OF  
 BEL STEWART CONNECTOR AND SHALL NOT BE REPRODUCED,  
 COPIED, OR USED IN ANY MANNER WITHOUT PRIOR WRITTEN  
 CONSENT OF BEL STEWART CONNECTOR. THE SUBJECT  
 MATTER MAY BE PATENTED OR A PATENT MAY BE PENDING.

DRN BY:	TRM	DATE	6-1-05
APPD BY:	RGC	DATE	6-1-05
DWG NO.	CT310014	REV.	B7