

DATE	REV	ECN	APP'D. BY
12-5-06	A3	7860	TRM
1-17-08	A4	8341	TRM
5-12-09	A5	8735	TRM

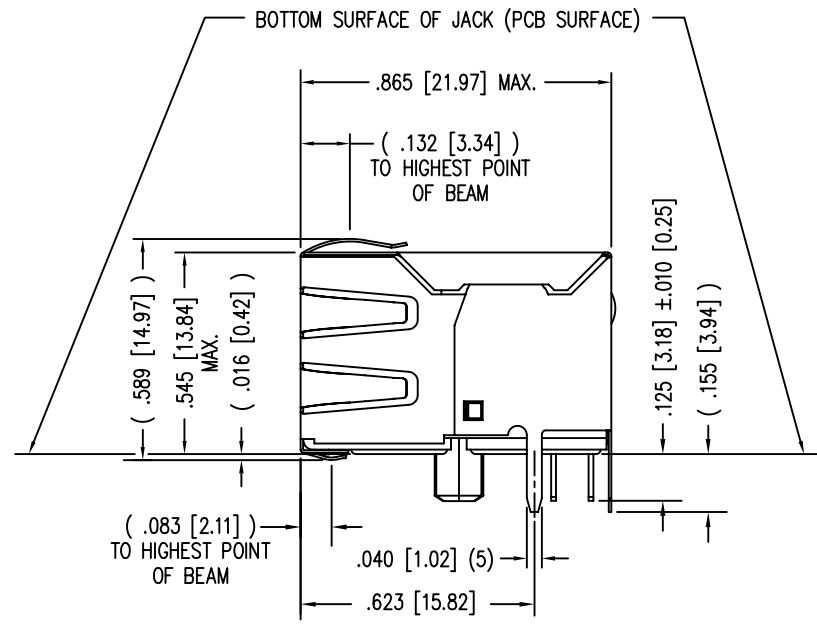
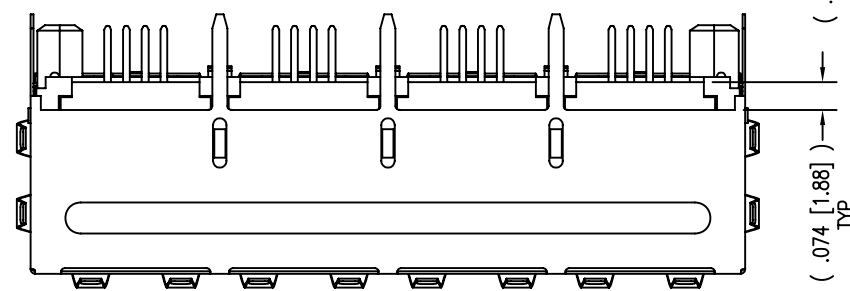
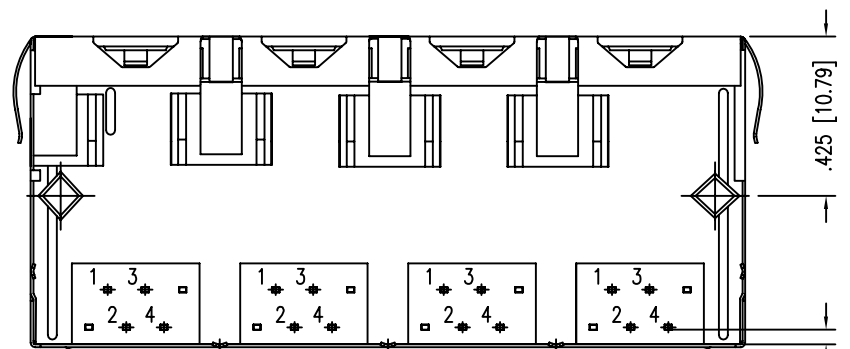
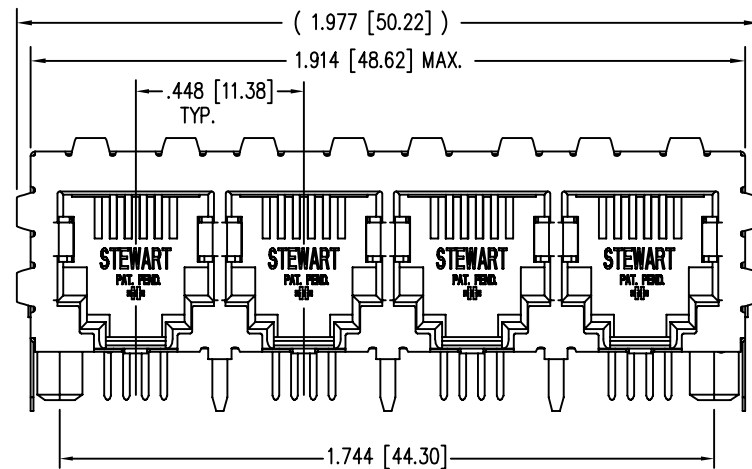
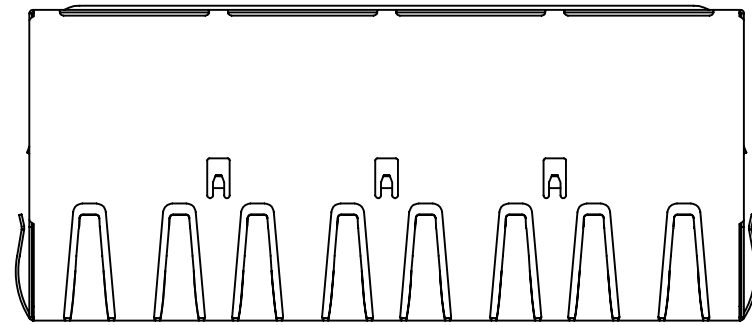

- NOTES:
- CONNECTOR MATERIALS:
HOUSING: THERMOPLASTIC UL94 V-0
CONTACTS/SHIELD: COPPER ALLOY
SHIELD PLATING: NICKEL
CONTACT PLATING: SELECTIVE GOLD IN CONTACT AREA
SEE CHART FOR PART NUMBER
 - FOR PRODUCT SPECIFICATIONS SEE PR022-01.
 - DIMENSIONS AND TOLERANCES COMPLY WITH FCC/CFR 47, PART 68.
 - THE SUGGESTED PANEL OPENING IS INTENDED TO GIVE USER THE ABILITY TO HAVE REASONABLE JACK/PANEL CLEARANCES, YET MAINTAIN GROUNDING CAPABILITY. THESE VARIABLES CAN BE ADJUSTED IN EITHER DIRECTION BUT MAY CARRY SOME CONSEQUENCES IN THE FORM OF LOWER MATING FORCES OR TIGHTER ASSEMBLY TOLERANCES.

50 MICRO-INCHES [1.27um]	SS-664604S-A-PG4-AC-50
CONTACT PLATING IN MATING AREA	PART NUMBER

THIRD ANGLE PROJECTION

DO NOT SCALE DRAWING
DRAWING IS SUBJECT TO CHANGE WITHOUT NOTICE

DIMENSIONS: INCHES [METRIC]

UNLESS OTHERWISE SPECIFIED TOLERANCES ARE ±.005 [0.13] ANGLES ARE ± 1°

SHEET NO. 1 OF 2



Bel Stewart Connector

11118 Susquehanna Trail South
Glen Rock, PA 17327-9199
(717) 235-7512 Fax: (717) 235-7954 <http://www.stewartconnector.com>

TITLE: 4 PORT SHIELDED RJ11 HARMONICA JACK			
DRN BY:	JAF	DATE	2-2-06
APPD BY:	JM	DATE	2-2-06
DWG NO.	CT660205	REV.	A5

THIS DRAWING AND THE SUBJECT MATTER SHOWN THEREON ARE CONFIDENTIAL AND THE PROPRIETARY PROPERTY OF BEL STEWART CONNECTOR AND SHALL NOT BE REPRODUCED, COPIED, OR USED IN ANY MANNER WITHOUT PRIOR WRITTEN CONSENT OF BEL STEWART CONNECTOR. THE SUBJECT MATTER MAY BE PATENTED OR A PATENT MAY BE PENDING.

REV. 6/3/05

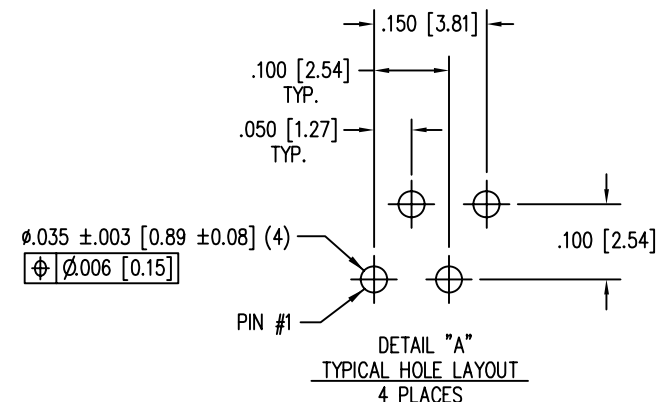
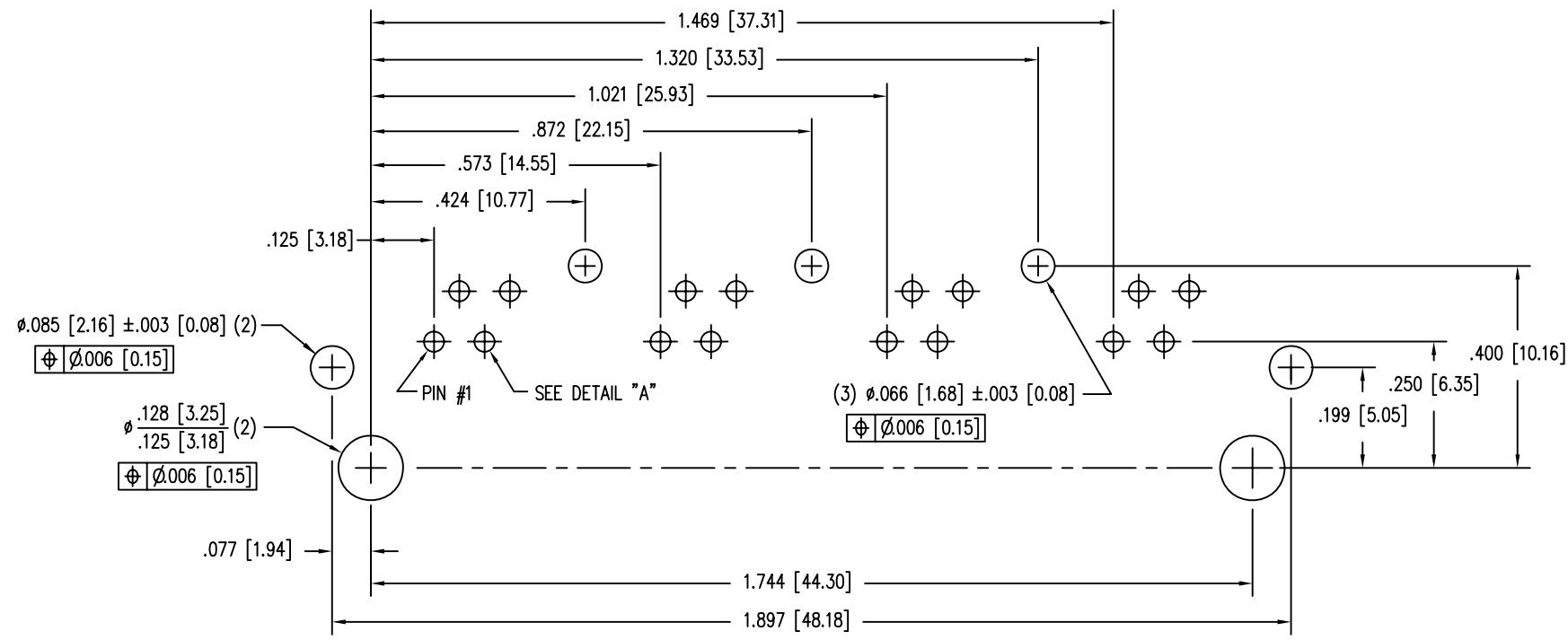

P.C.B. RECOMMENDED HOLE LAYOUT
SEEN FROM COMPONENT SIDE
ALL CENTERLINE DIMENSIONS ARE BASIC.

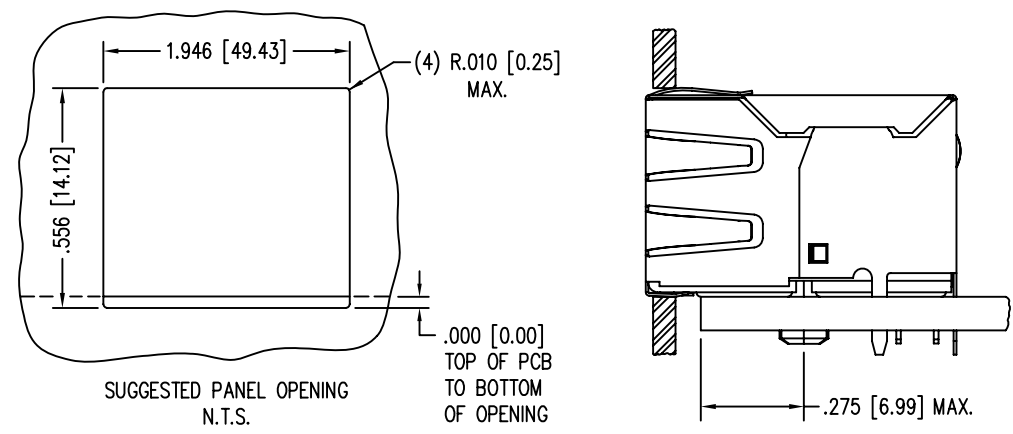

THIRD ANGLE PROJECTION		Bel Stewart Connector	
DO NOT SCALE DRAWING DRAWING IS SUBJECT TO CHANGE WITHOUT NOTICE		11118 Susquehanna Trail South Glen Rock, PA 17327-9199 (717) 235-7512 Fax: (717) 235-7954 http://www.stewartconnector.com	
DIMENSIONS: INCHES [METRIC]		TITLE: 4 PORT SHIELDED RJ11 HARMONICA JACK	
UNLESS OTHERWISE SPECIFIED TOLERANCES ARE ±.005 [0.13] ANGLES ARE ± 1°		THIS DRAWING AND THE SUBJECT MATTER SHOWN THEREON ARE CONFIDENTIAL AND THE PROPRIETARY PROPERTY OF BEL STEWART CONNECTOR AND SHALL NOT BE REPRODUCED, COPIED, OR USED IN ANY MANNER WITHOUT PRIOR WRITTEN CONSENT OF BEL STEWART CONNECTOR. THE SUBJECT MATTER MAY BE PATENTED OR A PATENT MAY BE PENDING.	
SHEET NO. 2 OF 2		DRN BY: JAF	DATE 2-2-06
		APPD BY: JM	DATE 2-2-06
		DWG NO. CT660205	REV. A5

REV. 6/3/05