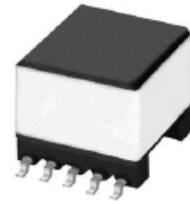
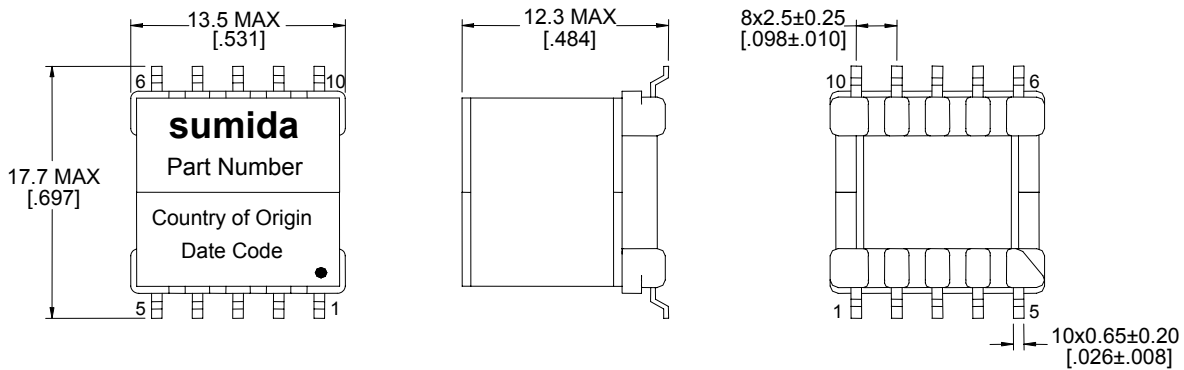
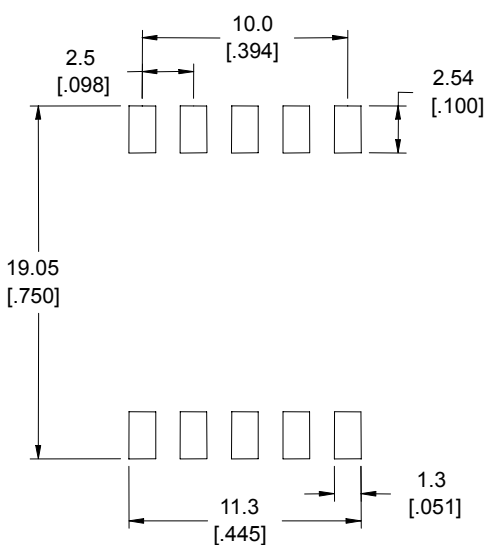
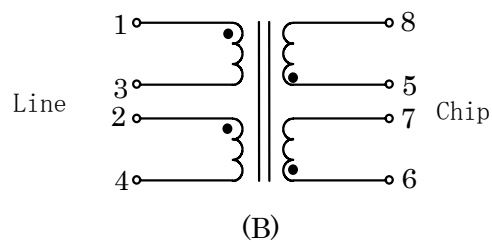
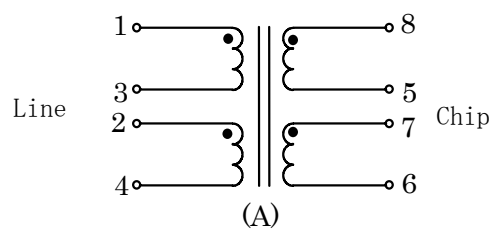

Type: CEP1311
◆ Product Description

- 17.7×13.5mm Max.(L×W),12.3mm Max. Height.

◆ Feature

- xDSL line transformer.
- Ideally used in ADSL customer premises equipment, SHDSL&HDSL, splitter and VDSL.
- Approved by TI, Silicon Labs, Broadcom and Conexant.
- RoHS Compliance.

◆ Dimensions (mm)

◆ Land Pattern (mm)

◆ Schematics(Bottom)

Type: CEP1311
◆ Specification

Part No.	Inductance (nom. μ H)	Turns ratio	THD (dB) (TYP.)	Insulation	Application
C10100	440	2:1		Supplementary	ADSL CPE
C10108	1500	2:1	-84 Max.(30K,5.3V)	Supplementary	ADSL CPE
C10120	1500	2:1	-84 (30K,5.3V)	Supplementary	ADSL CPE
C10122	409	2:1	-84 (30K,2.22V)	Supplementary	ADSL CPE
C10136	100	2:1	-92.7 (100K,2.25V)	Supplementary	ADSL CPE
C10166	400	2.35:1	-92.5 (30K,5.3V)	Supplementary	ADSL CPE
C10192	500	2:1	-90 (50K,4.3V)	Supplementary	ADSL CPE
C10193	750	2:1	-90 (50K,4.3V)	Supplementary	ADSL CPE
C10194	1000	2:1	-99.4 (50K,4.3V)	Supplementary	ADSL CPE
C13100	3000	5.4:1	-78(5kHz 4V)	Supplementary	SHDSL & HDSL
4367-T135	3019	2.25:2.25:1	-86(5kHz 1V)	Supplementary	SHDSL & HDSL
C15111	4000	1:1			Splitter
C15112	5000	1:1			Splitter
C14111	400	2.8:1	-90(100K,5V)	Supplementary	VDSL
C14112	750	5.33:1	-75(25K,2V)	Supplementary	VDSL
C14114	1000	1:1	-85(25K,2V)	Supplementary	VDSL
C14116	470	1.33:1	-83(25K,2V)	Supplementary	VDSL
C14121	100	2.8:1	-90.9(100K,4V)	Supplementary	VDSL
C14122	750	2:1	-77(25K,2V)	Supplementary	VDSL