

THE INFORMATION CONTAINED HEREIN IS CONSIDERED "PROPRIETARY" TO BEL FUSE INC. AND SHALL NOT BE COPIED, REPRODUCED OR DISCLOSED WITHOUT THE WRITTEN APPROVAL OF BEL FUSE INC.

ELECTRICAL CHARACTERISTICS @ 25°C

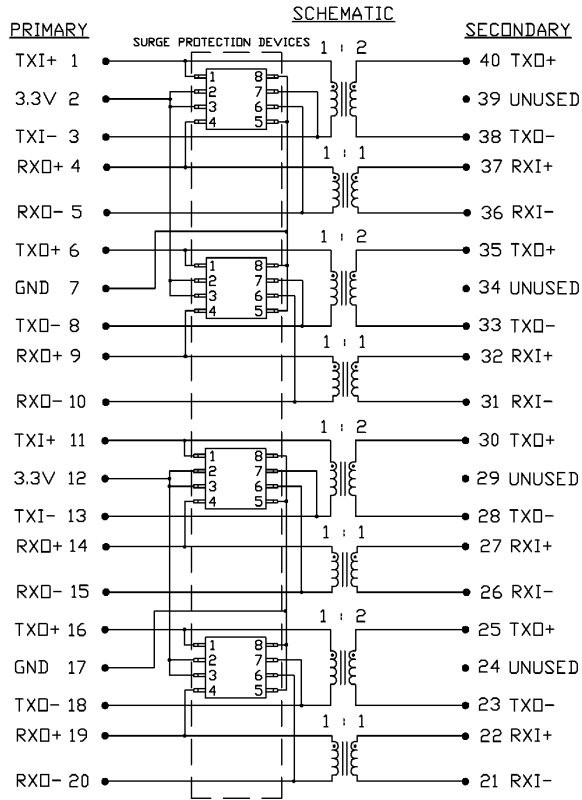

URNS RATIO

Tx PRIMARY : SECONDARY 1 : 2
 Rx PRIMARY : SECONDARY 1 : 1

INDUCTANCE

Tx PRIMARY 1.5 mH MIN. @10kHz, 10mV
 AT -40°C 640 μH MIN.
 Rx PRIMARY 1.8 mH MIN. @10kHz, 10mV
 AT -40°C 850 μH MIN.

LEAKAGE INDUCTANCE (Le)

Tx PRIMARY (SECONDARY SIDE SHORTED) 0.30 μH MAX. @1MHz, 20mV
 Rx PRIMARY (SECONDARY SIDE SHORTED) 0.50 μH MAX. @1MHz, 20mV

INTERWINDING CAPACITANCE (Cw/w)

Tx PRIMARY - SECONDARY 35pF MAX. @1MHz, 20mV
 Rx PRIMARY - SECONDARY 35pF MAX. @1MHz, 20mV

DC RESISTANCE

Tx PRIMARY 0.60 Ω MAX.
 Tx SECONDARY 1.20 Ω MAX.
 Rx PRIMARY & SECONDARY 0.60 Ω MAX.

HIPDT

REF. DOC. HAND-WORK-03

THE SURGE PROTECTION DEVICES

TVS DIODE ARRAYS : PROTEK PSRDA3.3-4-LF
 NUMBER OF ARRAYS : 4

*THE SURGE PROTECTION PROVIDED BY THE BEL MODULE IS EQUIVALENT TO THAT ADVERTISED IN THE PROTEK PSRDA3.3-4-LF PRODUCT SPECIFICATION

ORIGINATED BY	DATE	TITLE	PART NO. / DRAWING NO.	STANDARD DIM.	[] METRIC DIM. AS REFERENCE	 <small>COMPONENTS OF A CONNECTED PLANET</small>
HILLDY CHAN	08-24-07	ELECTRICAL SPECIFICATION S553-6500-B8-F	X5536500B8-F	TOL. IN INCH	UNIT : INCH [mm] REV. : B	
DRAWN BY	DATE		FILE NAME	.X	SCALE : N/A SIZE : A4	
DQ Chen	08-24-07		X5536500B8FB.DWG	.XX		
				.XXX		

THE INFORMATION CONTAINED HEREIN IS CONSIDERED "PROPRIETARY" TO BEL FUSE INC. AND SHALL NOT BE COPIED, REPRODUCED OR DISCLOSED WITHOUT THE WRITTEN APPROVAL OF BEL FUSE INC.

"In order to survive the high temperature (260C) reflow requirement of RoHS directive, the internal solder joints of this part need to use solder containing over 85% of lead. Exempted per RoHS directive Annex 7"

RoHS
2002/95/EC

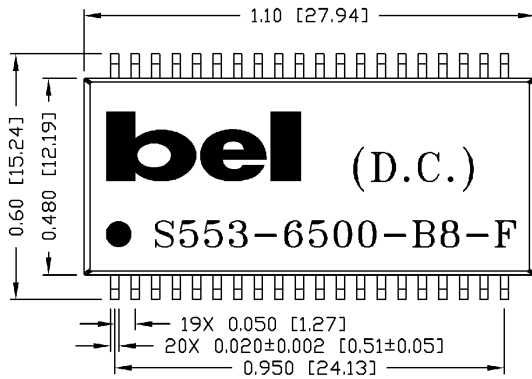

0.285±0.010
[7.24±0.25]

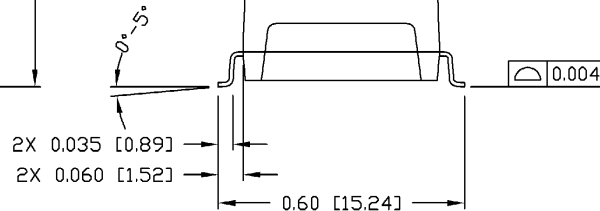
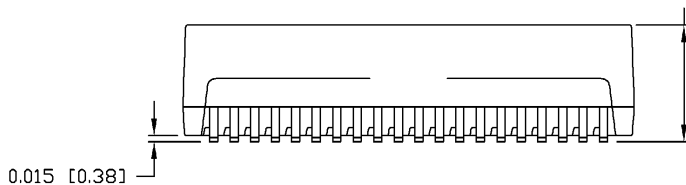
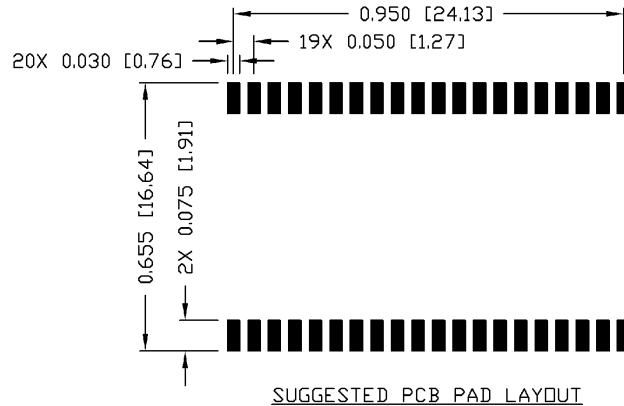

NOTES:

- STANDARD MARKING REFER TO DOC. HAND-WORK-04.
- PACKAGE CODE: "DIS002".

ORIGINATED BY Lawrence Tsang	DATE 08-24-07	TITLE MECHANICAL SPECIFICATION S553-6500-B8-F	PART NO. / DRAWING NO. X5536500B8-F	STANDARD DIM. TOL. IN INCH	[] METRIC DIM. AS REFERENCE
DRAWN BY DQ Chen	DATE 08-24-07		FILE NAME X5536500B8FB.DWG	.X ±0.01 .XXX ±0.005	UNIT : INCH [mm] SCALE : N/A REV. : B SIZE : A4 PAGE : 3

