

◆ Description

The SN431 series are 3-terminal precision shunt regulators that are programmable over a wide voltage range of 2.495V to 36V with $\pm 0.5\%$, $\pm 1.0\%$ tolerance. The SN431 series have a low dynamic impedance of $0.15\ \Omega$. These features make the SN431 series an excellent replacement for zener diodes in numerous applications circuits that require a precision reference voltage.

◆ Features

- Programmable output voltage from 2.495V to 36V
- Voltage reference tolerance : $\pm 0.5\%$, $\pm 1.0\%$
- Cathode current capability of 1mA to 100mA

◆ Pin Assignment

(Top View)



PKG : SOT-89
Apply Device : SN431xF

(Top View)

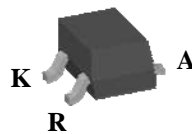

PKG : SOT-23
Apply Device : SN431xS

(Top View)

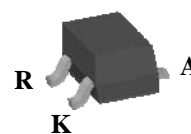

PKG : SOT-23
Apply Device : SNF431xS

(Top View)

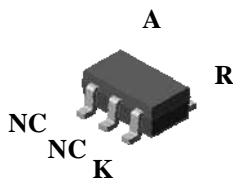

PKG : SOT-25
Apply Device : SN431xN

(Marking Side View)

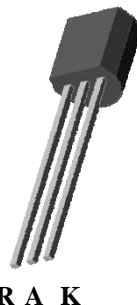

PKG : TO-92
Apply Device : SN431x

(Marking Side View)

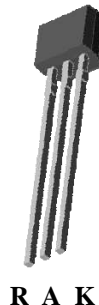

PKG : TO-92M
Apply Device : SN431xM

[K : Cathode, A: Anode, R : Reference]

◆ Symbol

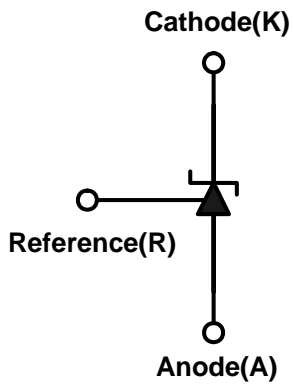

◆ Functional block diagram

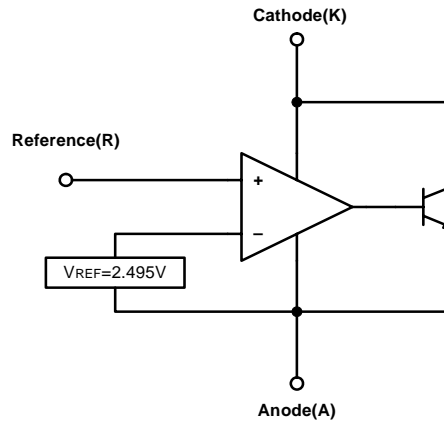

◆ Ordering Information

Vref Tolerance	PKG Type	Device Name	Marking
± 1%	TO-92	SN431A	SN431A
	TO-92M	SN431AM	SN431A
	SOT-23	SN431AS ¹⁾	4GA□ ³⁾
	SOT-23	SNF431AS ²⁾	4KA□ ³⁾
	SOT-25	SN431AN	N4A□ ³⁾
	SOT-89	SN431AF	SN431A
± 0.5%	TO-92	SN431B	SN431B
	TO-92M	SN431BM	SN431B
	SOT-23	SN431BS ¹⁾	4GB□ ³⁾
	SOT-23	SNF431BS ²⁾	4KB□ ³⁾
	SOT-25	SN431BN	N4B□ ³⁾
	SOT-89	SN431BF	SN431B

1) SN431x Pin Connection : 1. Cathode, 2. Reference, 3. Anode

2) SNF431x Pin Connection : 1. Reference, 2. Cathode, 3. Anode

3) □ : Year & Week Code

◆ Absolute maximum ratings

[Ta=25°C]

Characteristic		Symbol	Rating	Unit
Cathode to Anode voltage		V_{KA}	37	V
Cathode current		I_K	150	mA
Reference input current		I_{ref}	10	mA
Power Dissipation	SOT-23	P_D (Note1)	350	mW
	SOT-25	P_D (Note1)	400	
	SOT-89	P_D (Note1)	500	
	TO-92	P_D (Note2)	625	
	TO-92M	P_D (Note2)	400	
Junction Temperature		T_J	150	°C
Operating temperature range		T_{opr}	-40 ~ +85	°C
Storage temperature range		T_{stg}	-55 ~ +150	°C

Note 1 : Mounted on a glass epoxy PCB board (25.4 × 25.4mm). $T_A=25^\circ\text{C}$

Note 2 : $T_A=25^\circ\text{C}$

◆ Recommended operating conditions

Characteristic	Symbol	Rating		Unit
		Min.	Max.	
Cathode to Anode voltage	V_{KA}	V_{ref}	36	V
Cathode current	I_K	1	100	mA

◆ Electrical Characteristics (Ta=25°C, unless otherwise noted.)

Characteristic	Symbol	Condition	Min.	Typ.	Max.	Unit	
Reference voltage (Fig.1)	V_{ref}	$V_{KA}=V_{ref}, I_K=10\text{mA}$	SN431B	2.482	2.495	2.508	V
			SN431A	2.470		2.520	
Reference input voltage deviation over temperature (Fig.1, Note1,2)	ΔV_{ref}	$V_{KA}=V_{ref}, I_K=10\text{mA}$ @ -40°C ≤ Ta ≤ 85°C	-	7	30	mV	
Ratio of delta reference input voltage to delta cathode voltage (Fig.2)	$\frac{\Delta V_{ref}}{\Delta V_{KA}}$	$I_K=10\text{mA}$ $V_{ref} \leq V_{KA} \leq 36\text{V}$	-	-1.0	-2.7	mV/V	
Reference current (Fig.2)	I_{ref}	$I_K=10\text{mA}, R1=10\text{K}\Omega, R2=\infty$	-	1.8	4.0	μA	
Reference input current deviation over temperature (Fig.2, Note 1,2)	ΔI_{ref}	$I_K=10\text{mA}, R1=10\text{K}\Omega, R2=\infty$ @ -40°C ≤ Ta ≤ 85°C	-	0.4	2.5	μA	
Minimum cathode current for regulation	$I_{K(MIN)}$	$V_{KA}=V_{ref}$	-	0.35	1.0	mA	
Off-state cathode current (Fig.3)	$I_{K(off)}$	$V_{KA}=36\text{V}, V_{ref}=0\text{V}$	-	2.7	1000	nA	
Dynamic impedance (Fig.1, Note3)	Z_{KA}	$V_{KA}=V_{ref}, f \leq 1.0\text{KHz}$ $1.0\text{mA} \leq I_K \leq 100\text{mA}$	-	0.15	0.5	Ω	

Fig. 1 Test circuit for $V_{KA}=V_{ref}$

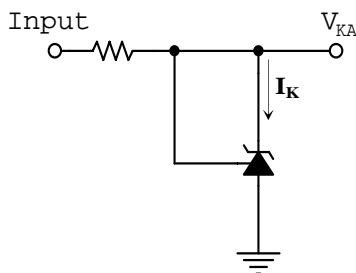

Fig. 2 Test circuit for $V_{KA}>V_{ref}$

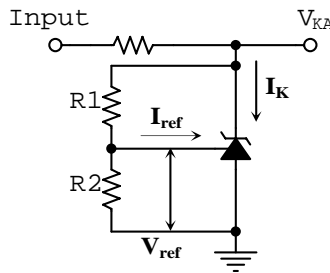
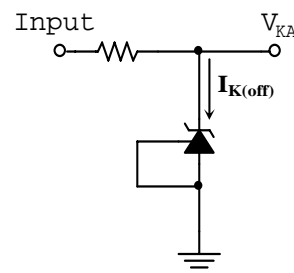

Fig. 3 Test circuit for $I_{K(off)}$



$$V_{KA} = V_{ref} \times \left(1 + \frac{R_1}{R_2}\right) + I_{ref} \times R_1$$

Note.

1. Ambient temperature range: $T_{LOW} = -40^{\circ}\text{C}$, $T_{High} = 85^{\circ}\text{C}$
2. The deviation parameters ΔV_{ref} and ΔI_{ref} are defined as the difference between the maximum value and minimum value obtained over the full operating ambient temperature range that applied.

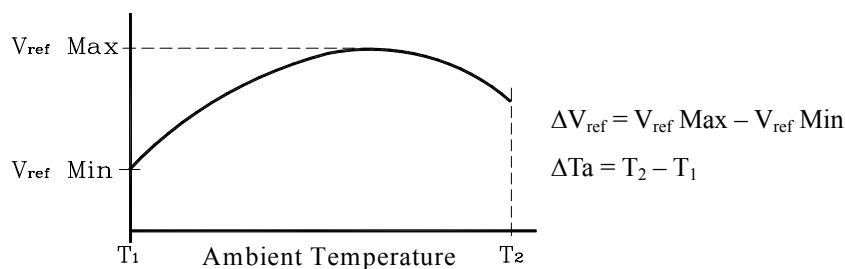

The average temperature coefficient of the reference input voltage, αV_{ref} is defined as:

$$\alpha V_{ref} \left(\frac{\text{ppm}}{^{\circ}\text{C}}\right) = \frac{\left(\frac{\Delta V_{ref}}{V_{ref}(T_a = 25^{\circ}\text{C})} \times 10^6\right)}{\Delta T_a}$$

Example : $\Delta V_{ref} = 30\text{mV}$ and the slope is positive,

$$\Delta V_{ref} @ 25^{\circ}\text{C} = 2.495\text{V}$$

$$\Delta T_a = 70^{\circ}\text{C}$$

$$\alpha V_{ref} \left(\frac{\text{ppm}}{^{\circ}\text{C}}\right) = \frac{\left(\frac{0.03}{2.495}\right) \times 10^6}{70} = 171\text{ppm}/^{\circ}\text{C}$$

3. The dynamic impedance Z_{KA} is defined as:

$$|Z_{KA}| = \frac{\Delta V_{KA}}{\Delta I_K}$$

When the device is operating with two external resistors, R1 and R2, (refer to Fig.2) the total dynamic impedance of the circuit is given by:

$$|Z_{KA}'| = |Z_{KA}| \times \left(1 + \frac{R_1}{R_2}\right)$$

◆ Electrical Characteristic Curves

Fig.4 V_{ref} vs T_A

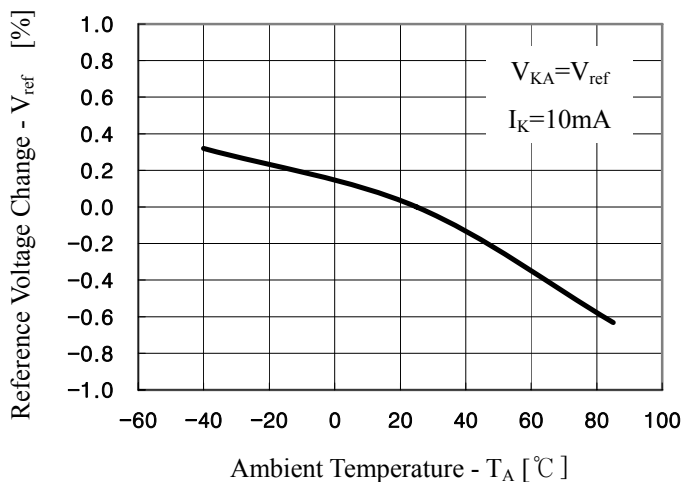

Fig.5 I_{ref} vs T_A

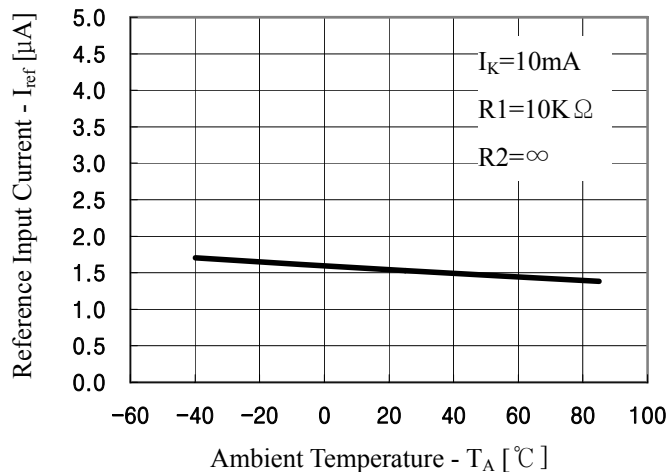

Fig.6 I_{KA} vs V_{KA}

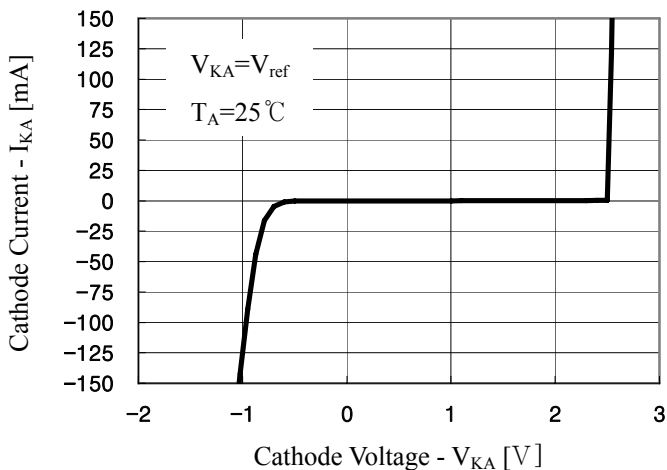

Fig.7 I_{KA} vs V_{KA}

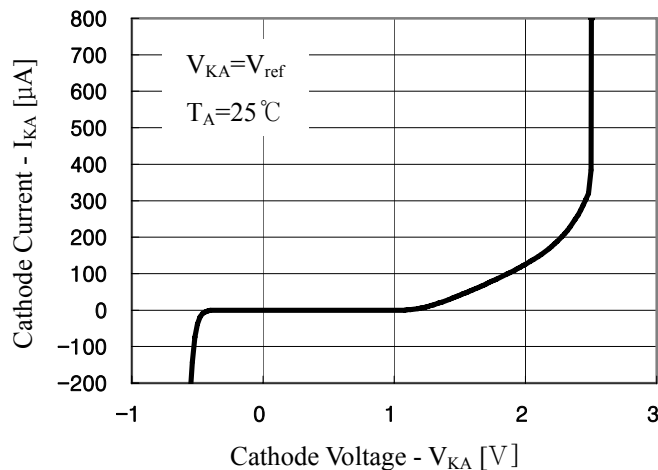

Fig.8 I_{off} vs T_A

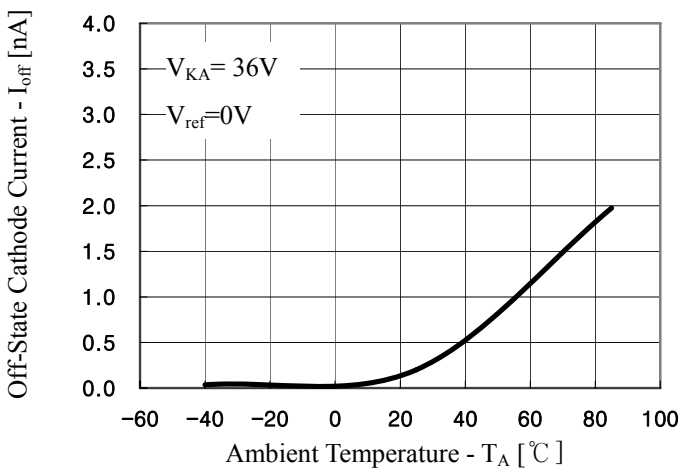
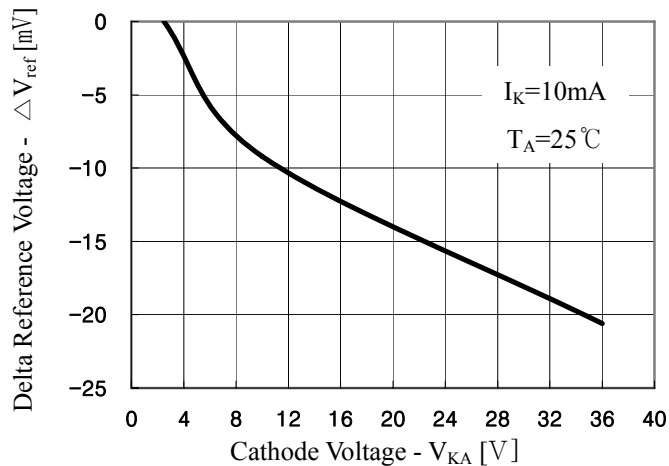
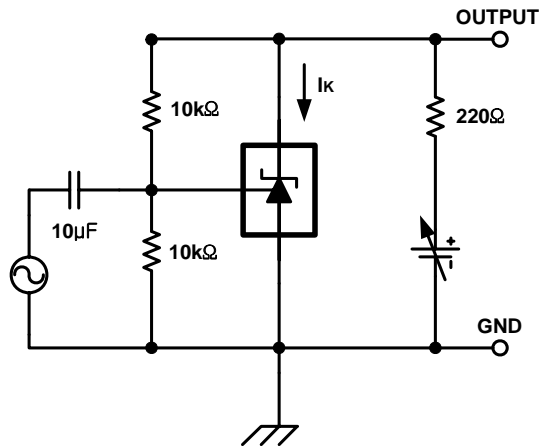
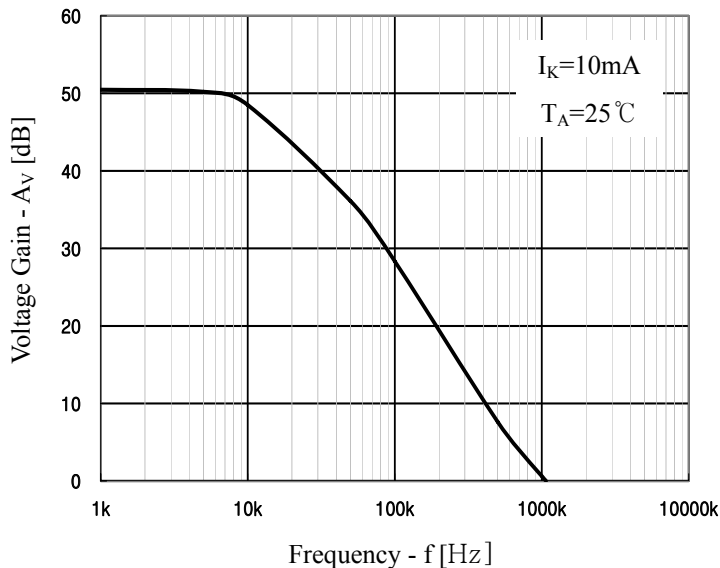

Fig.9 ΔV_{ref} vs V_{KA}



◆ Electrical Characteristic Curves

Fig.10 A_V vs f



Voltage Gain Test Circuit

Fig.11 $|Z_{KA}|$ vs f

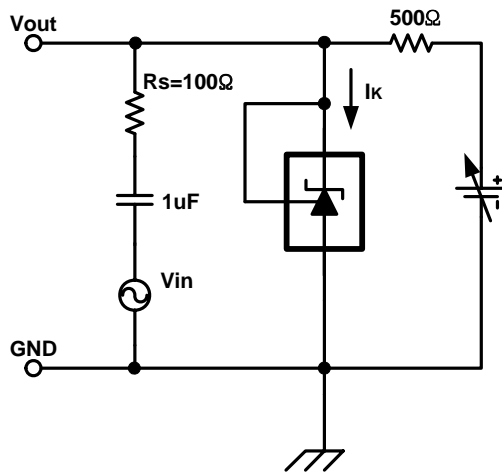
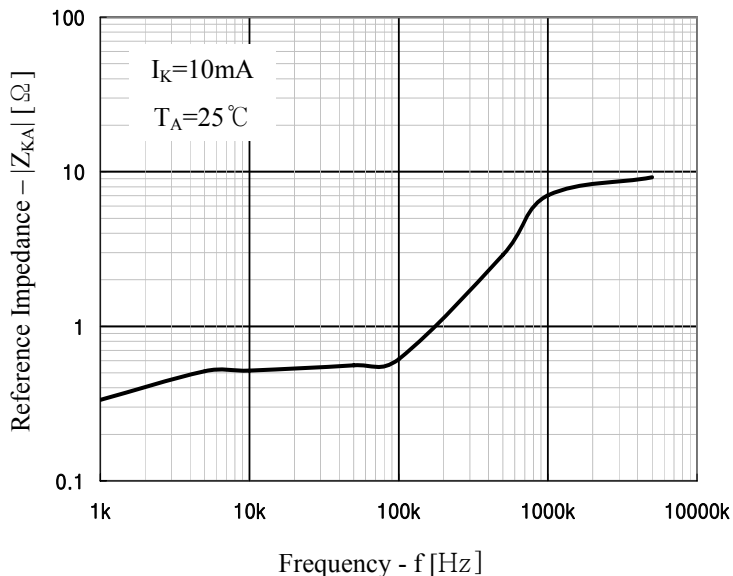

$$Z_{KA} = V_{out}/V_{in} \times R_s$$

Dynamic Impedance Test Circuit

Fig.12 Pulse Response

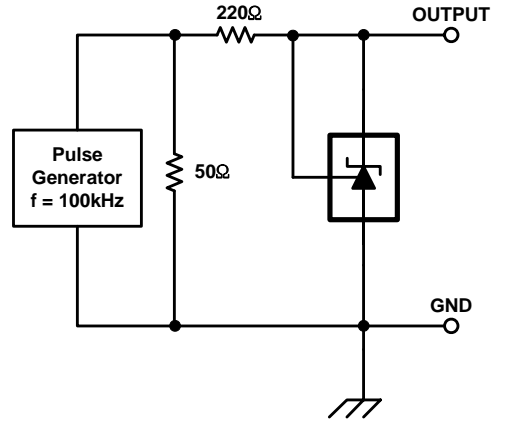
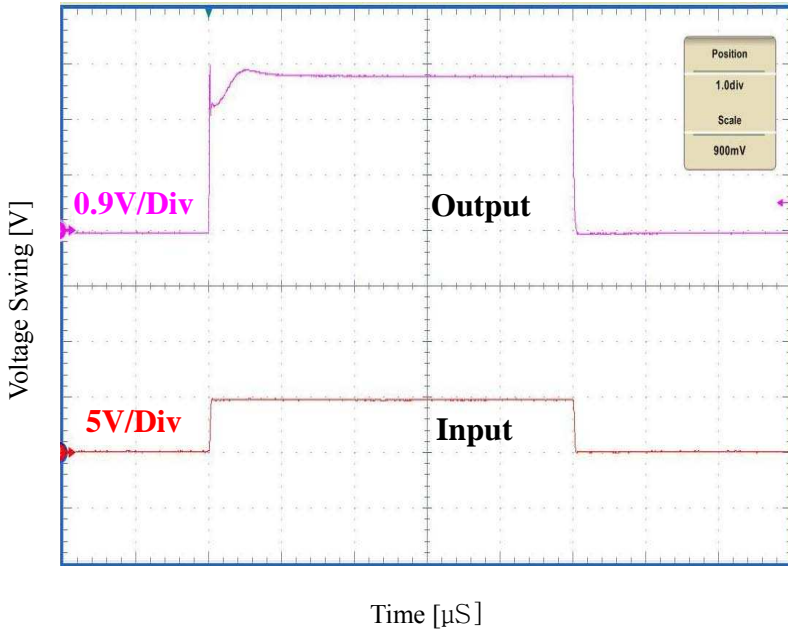

Pulse Response Test Circuit

◆ Typical Application

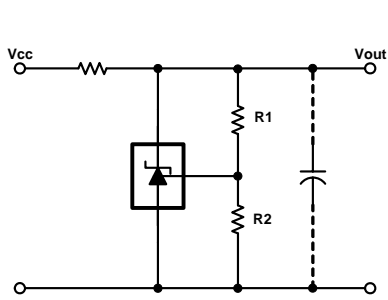

$$V_{out} = \left(1 + \frac{R1}{R2}\right) V_{ref}$$

Fig14. Shunt Regulator

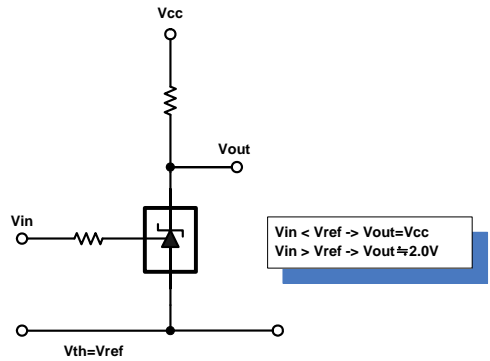
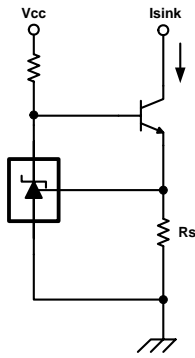
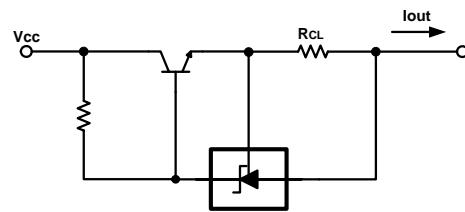

Fig15. Single-Supply Comparator with Temperature-Compensated Threshold



$$I_{sink} = V_{ref} / R_s$$

Fig16. Constant Current Sink



$$I_{out} = V_{ref} / R_{CL}$$

Fig17. Constant Current Source

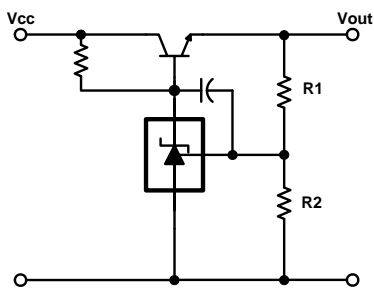

$$V_{out} = \left(1 + \frac{R1}{R2}\right) V_{ref}$$

$$V_{in(min)} = V_{out} + V_{be}$$

$$V_{out(min)} = V_{ref} + V_{be}$$

Fig18. Series Pass Regulator

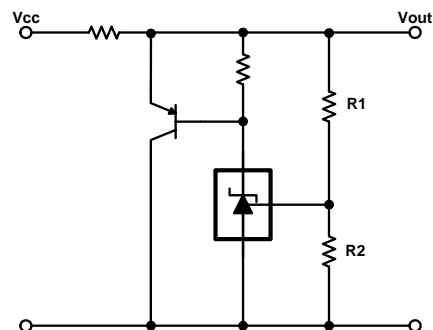

$$V_{out} = \left(1 + \frac{R1}{R2}\right) V_{ref}$$

Fig19. High Current Shunt Regulator

◆ SOT-89 Outline Dimension (unit : mm)

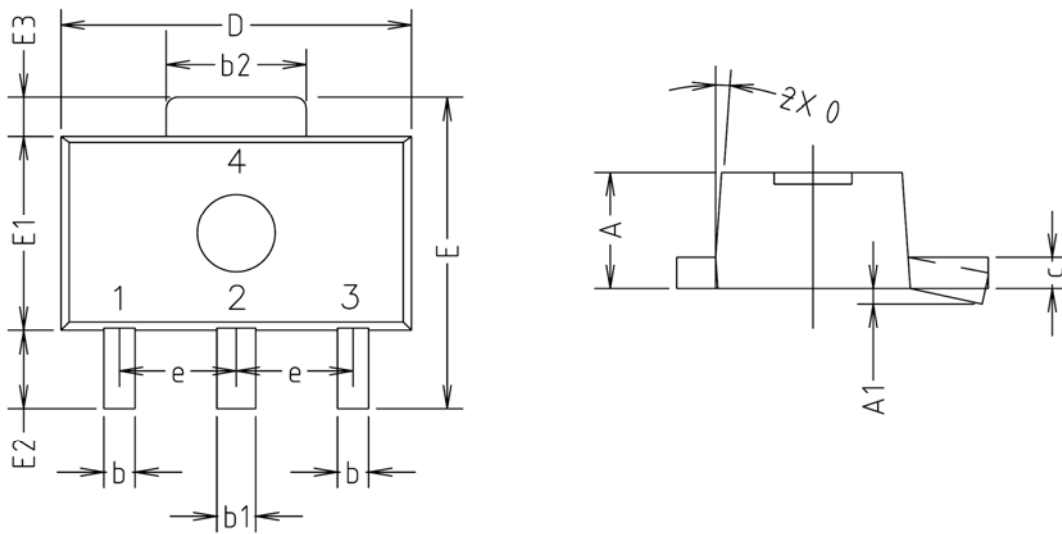

SYMBOL	MILLIMETERS			NOTE
	MINIMUM	NOMINAL	MAXIMUM	
A	1.40	1.50	1.60	
A1	0.00	—	0.10	
b	0.38	0.42	0.48	
b1	0.48	0.52	0.58	
b2	1.79	1.82	1.87	
c	0.40	0.42	0.46	
D	4.40	4.50	4.70	
E	3.70	4.00	4.30	
E1	2.40	2.50	2.70	
E2	0.80	1.00	1.20	
E3	0.40	0.50	0.60	
e	1.50 TYP.			
θ	4° TYP.			

※ Recommend PCB solder land [Unit: mm]

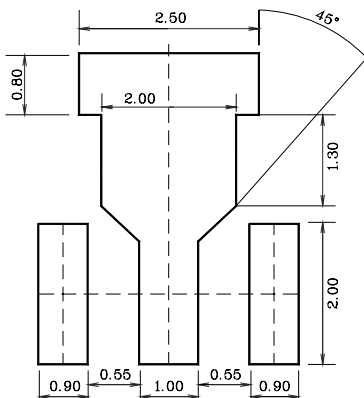

◆ SOT-23 Outline Dimension (unit : mm)

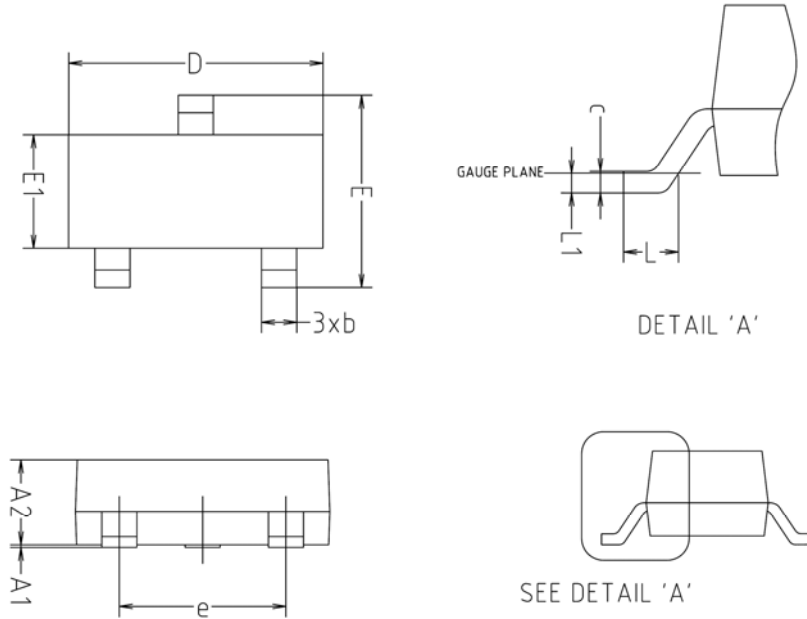

SYMBOL	MILLIMETERS			NOTE
	MINIMUM	NOMINAL	MAXIMUM	
A1	0.00	-	0.10	
A2	0.82	-	1.02	
b	0.39	0.42	0.45	
c	0.09	0.12	0.15	
D	2.80	2.90	3.00	
E	2.20	2.40	2.60	
E1	1.20	1.30	1.40	
e	1.90BSC			
L	0.20	-	-	
L1	0.12BSC			

※ Recommend PCB solder land [Unit: mm]

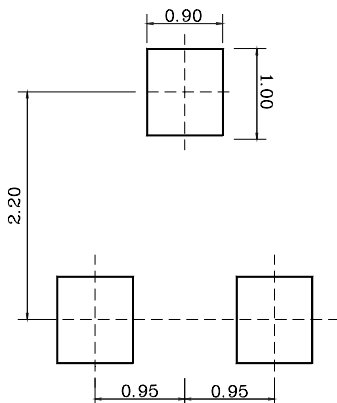

◆ SOT-25 Outline Dimension (unit : mm)

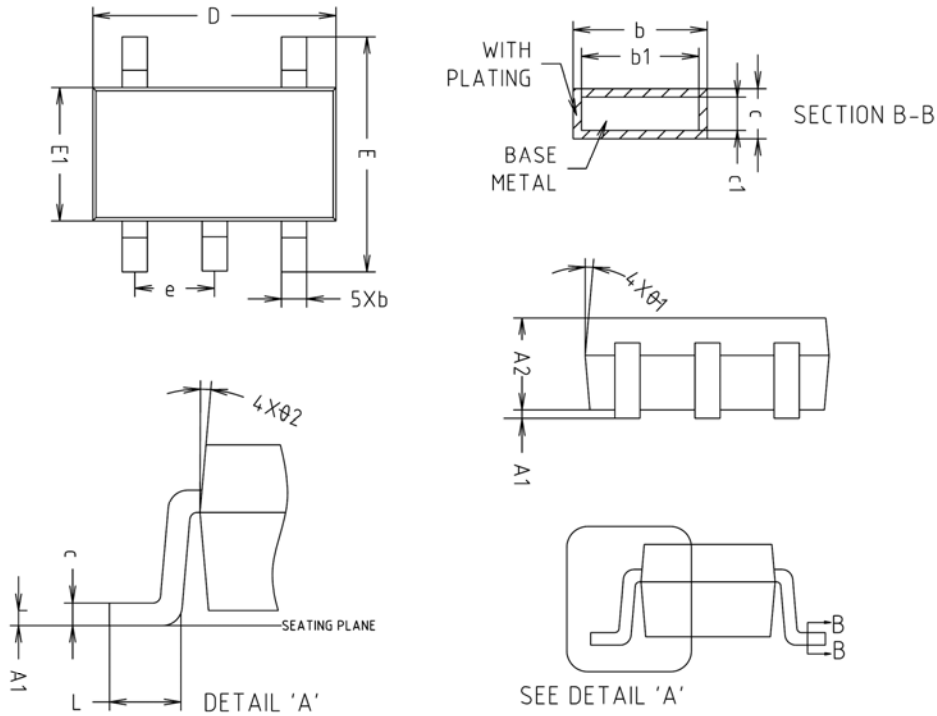

SYMBOL	MILLIMETERS			NOTE
	MINIMUM	NOMINAL	MAXIMUM	
A1	0.000	0.050	0.100	
A2	1.000	1.100	1.200	
b	-	0.400	0.450	
b1	-	0.375	0.425	
c	0.110	0.150	0.190	
c1	0.085	0.125	0.165	
D	2.800	2.900	3.000	
E	2.600	2.800	3.000	
E1	1.500	1.600	1.700	
e	0.930	0.950	0.970	
L	0.400	-	-	
θ1	5° REF			
θ2	5° REF			

※ Recommend PCB solder land [Unit: mm]

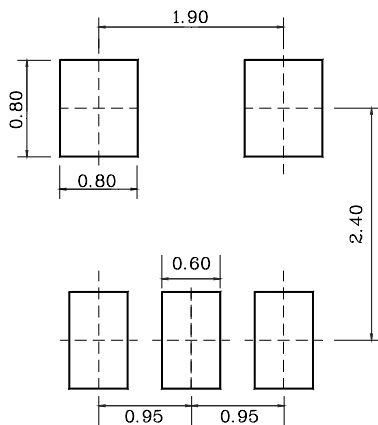

◆ TO-92 Outline Dimension (unit : mm)

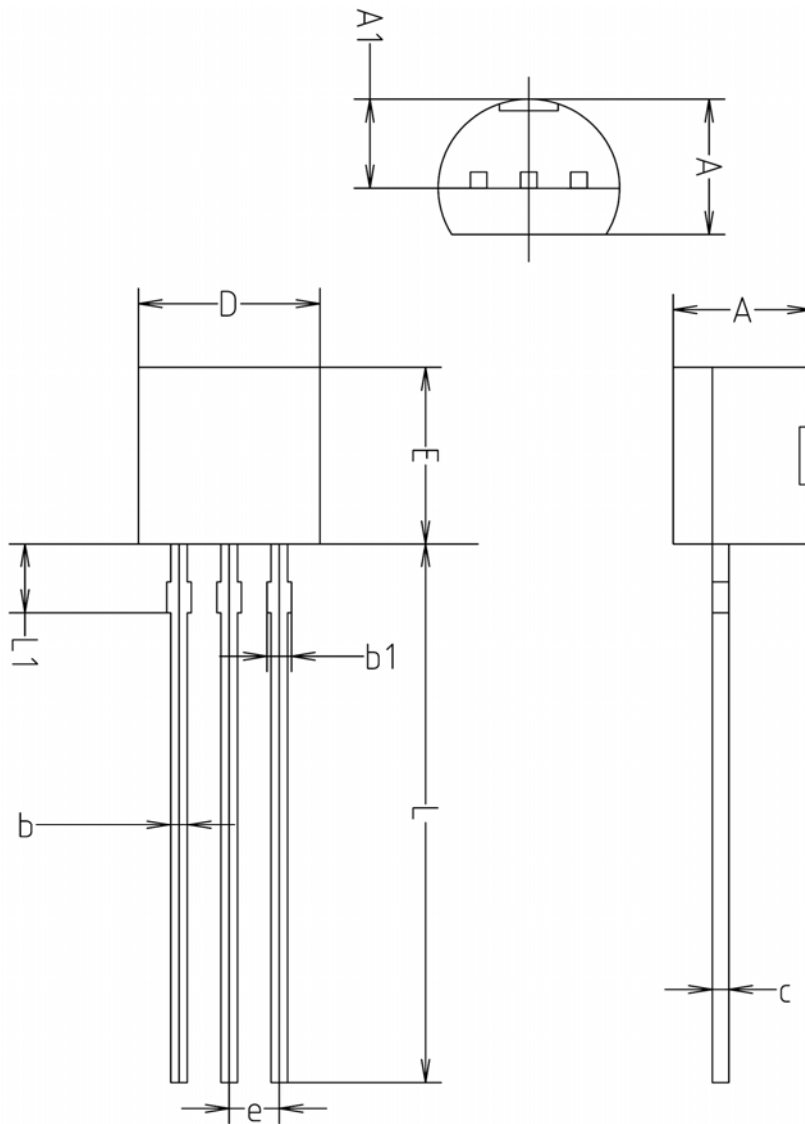

SYMBOL	MILLMETERS(mm)		
	MINIMUM	NOMINAL	MAXIMUM
A	3.40	3.50	3.66
A1	2.46	2.51	2.59
b	0.39	0.44	0.53
b1	0.39	—	0.63
c	0.35	0.42	0.47
D	4.48	4.60	4.70
E	4.48	4.60	4.70
e	1.17	1.27	1.37
L	13.70	14.00	14.77
L1	1.55	1.70	2.15

◆ TO-92M Outline Dimension (unit : mm)

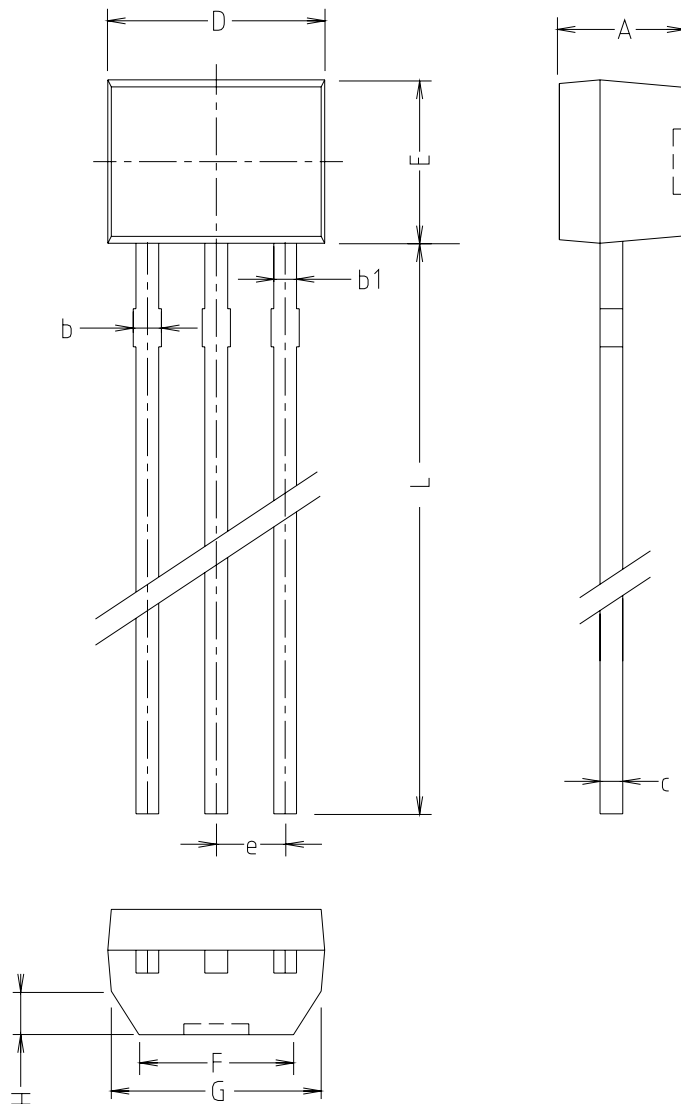

SYMBOL	MILLMETERS(mm)		
	MINIMUM	NOMINAL	MAXIMUM
A	2.20	2.30	2.40
b	—	0.50	—
b1	—	0.44	—
c	—	0.42	—
D	3.90	4.00	4.10
E	2.90	3.00	3.10
e	—	1.27	—
L	—	14.50	15.00
F	2.80	2.85	2.90
G	3.80	—	—
H	—	0.70	—

The AUK Corp. products are intended for the use as components in general electronic equipment (Office and communication equipment, measuring equipment, home appliance, etc.).

Please make sure that you consult with us before you use these AUK Corp. products in equipments which require high quality and / or reliability, and in equipments which could have major impact to the welfare of human life(atomic energy control, airplane, spaceship, transportation, combustion control, all types of safety device, etc.). AUK Corp. cannot accept liability to any damage which may occur in case these AUK Corp. products were used in the mentioned equipments without prior consultation with AUK Corp..

Specifications mentioned in this publication are subject to change without notice.