

◆ Descriptions

The SJ1117 series of positive adjustable and fixed regulators are designed to provide 1A with high efficiency. All internal circuitry is designed to operate down to 1.1V input to output differential. The SJ1117 offers current limiting and thermal shutdown and over voltage protection.

◆ Features

- Adjustable or fixed output(1.2V, 1.5V, 1.8V, 2.5V, 2.85V, 3.3V, 5V)
- Output current of 1A
- Safe Operating Area(SOA) Protection
- Over Voltage Protection (OVP)
- Over Current Protection (OCP)
- Thermal shutdown protection
- Low dropout, 1.1V Typical at 1A output current
- Operating temperature range : -40°C ~ +125°C
- Halogen-Free Package is Available
- High Level ESD Protection : 400V(MM), 4KV(HBM)

◆ Typical Applications

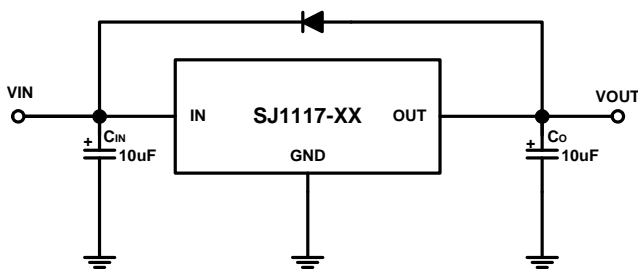

Fig.1 Fixed Voltage Regulator

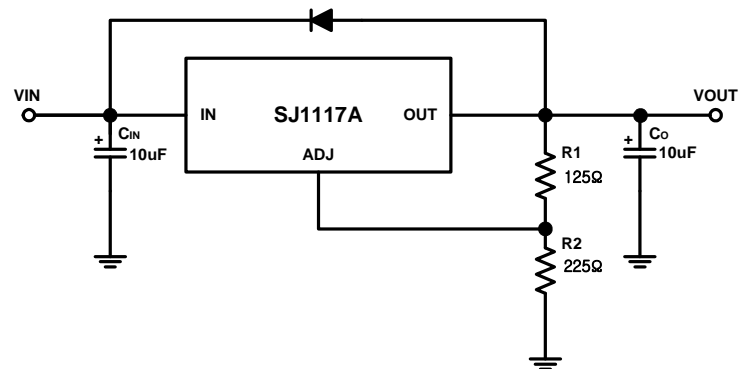

Fig.2 Adjustable Voltage Regulator

※ Notes

- 1) C_{IN} needed if device is far from filter capacitors
- 2) C_O minimum value required for stability

$$V_{out} = V_{ADJ} \times \left(1 + \frac{R_2}{R_1}\right) + I_{ADJ} \times R_2$$

◆ PIN Connection (Top View)

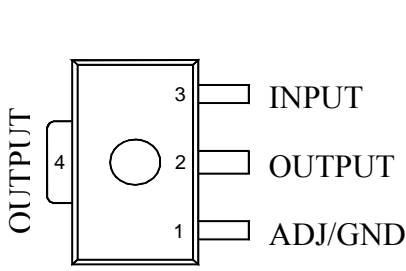

PKG : SOT-89

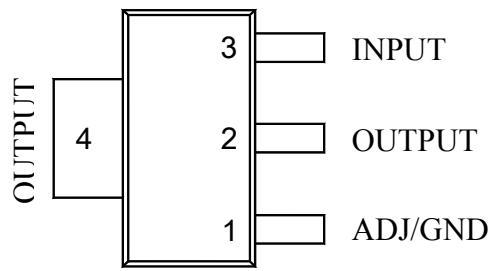

PKG : SOT-223

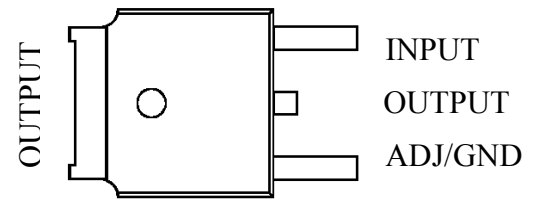

PKG : TO-252

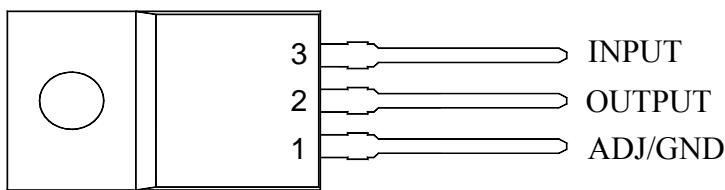

PKG : TO-220F-3L

◆ BLOCK DIAGRAM

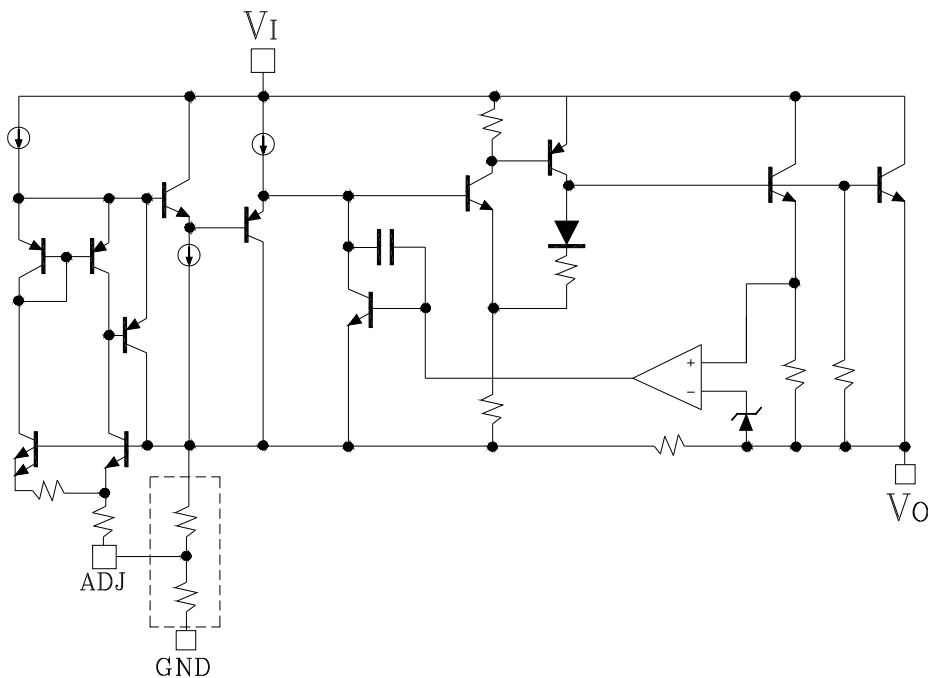

◆Ordering Information

Package Type	V_{OUT}	Device Name	Marking
SOT-89	ADJ	SJ1117-AF	S17A
	1.2V	SJ1117-12F	S1712
	1.5V	SJ1117-15F	S1715
	1.8V	SJ1117-18F	S1718
	2.5V	SJ1117-25F	S1725
	2.85V	SJ1117-285F	S17285
	3.3V	SJ1117-33F	S1733
	5.0V	SJ1117-50F	S1750
SOT-223	ADJ	SJ1117-AQ	SJ1117A
	1.2V	SJ1117-12Q	SJ111712
	1.5V	SJ1117-15Q	SJ111715
	1.8V	SJ1117-18Q	SJ111718
	2.5V	SJ1117-25Q	SJ111725
	2.85V	SJ1117-285Q	SJ1117285
	3.3V	SJ1117-33Q	SJ111733
	5.0V	SJ1117-50Q	SJ111750
TO-252	ADJ	SJ1117-AD	SJ1117AD
	1.2V	SJ1117-12D	SJ111712D
	1.5V	SJ1117-15D	SJ111715D
	1.8V	SJ1117-18D	SJ111718D
	2.5V	SJ1117-25D	SJ111725D
	2.85V	SJ1117-285D	SJ1117285D
	3.3V	SJ1117-33D	SJ111733D
	5.0V	SJ1117-50D	SJ111750D
TO-220F-3L	ADJ	SJ1117-API	SJ1117API
	1.2V	SJ1117-12PI	SJ111712PI
	1.5V	SJ1117-15PI	SJ111715PI
	1.8V	SJ1117-18PI	SJ111718PI
	2.5V	SJ1117-25PI	SJ111725PI
	2.85V	SJ1117-285PI	SJ1117285PI
	3.3V	SJ1117-33PI	SJ111733PI
	5.0V	SJ1117-50PI	SJ111750PI

◆ Absolute Maximum Ratings

[Ta=25°C]

Characteristic	Symbol	Rating	Unit	
Input voltage	V_I	16	V	
Power Dissipation	SOT-89	P_{D1} (Note1)	0.4	W
		P_{D2} (Note2)	0.5	
	SOT-223	P_{D1} (Note1)	1.0	
		P_{D2} (Note2)	1.4	
	TO-252	P_{D1} (Note1)	1.4	
		P_{D2} (Note2)	2.7	
	TO-220F-3L	P_{D1} (Note1)	2.0	
		P_{D2} (Note3)	24	
Junction Temperature	T_J	150	°C	
Operating temperature range	T_{opr}	-40 ~ +125	°C	
Storage temperature range	T_{stg}	-55 ~ +150	°C	

Note 1 : $T_A=25^\circ\text{C}$ (No Heat sink)

Note 2 : Mounted on a glass epoxy PCB board (25.4 × 25.4mm).

Note 3 : $T_C=25^\circ\text{C}$ (Used Heat sink)

◆ Recommended Operating Conditions

Characteristic	Symbol	Min.	Max.	Unit
Input voltage	V_I	$V_O+1.5\text{V}$	$V_O+7\text{V}$	V
Output current	I_O	10	1000	mA

◆ Safe Operating Area

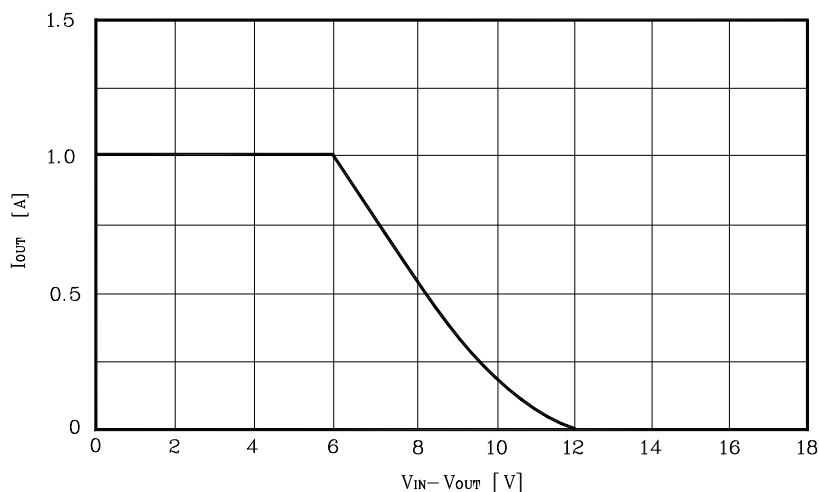

◆ Electrical Characteristics

 (Electrical Characteristics at $T_A=25^\circ\text{C}$ and $V_I=(V_O+1.5\text{V})$, $I_O=10\text{mA}$, $C_O=10\mu\text{F}$, unless otherwise specified.)

Characteristic	Symbol	Device	Test Condition	Min	Typ	Max	Unit
Output voltage	V_{OUT}	SJ1117A	$V_I = (V_O+1.5\text{V}) \text{ to } 7\text{V}$ $I_O = 10\text{mA to } 1000\text{mA}$	1.225	1.25	1.275	V
		SJ1117-12		1.140	1.20	1.260	
		SJ1117-15		1.470	1.50	1.530	
		SJ1117-18		1.764	1.80	1.836	
		SJ1117-25		2.450	2.50	2.550	
		SJ1117-285		2.793	2.85	2.907	
		SJ1117-33		3.234	3.30	3.366	
		SJ1117-50		4.900	5.00	5.100	
Line regulation (Note4)	$ \Delta V_{O(\Delta V_I)} $	All	$1.5\text{V} \leq V_I - V_O \leq 7\text{V}$ $I_O=10\text{mA}$	-	0.05	0.4	%
Load regulation (Note4)	$ \Delta V_{O(\Delta I_L)} $	All	$1.5\text{V} \leq V_I - V_O \leq 7\text{V}$ $I_O=10\text{mA} \sim 1000\text{mA}$	-	0.1	0.5	%
Quiescent current	I_Q	All	$I_O=0$	-	5	10	mA
Minimum load current	$I_{L(\text{MIN})}$	SJ1117A	$V_{\text{in}}=2.75\text{V}$	-	1	5	mA
Adjust pin current	I_{ADJ}	SJ1117A	$V_I = 2.75\text{V}$ $I_O = 100\text{mA}$	-	36	90	μA
Adjust pin current change	$ \Delta I_{\text{ADJ}} $	SJ1117A	$2.75\text{V} \leq V_I \leq 8.25\text{V}$ $I_O=10\text{mA} \sim 1000\text{mA}$	-	1	5	μA
Dropout voltage	V_{DROP}	All	$I_O=1000\text{mA}$	-	1.1	1.25	V
Ripple rejection ratio	RR	All	$V_I = V_O+3\text{V}$, $I_O=500\text{mA}$ $V_{\text{Ripple}}=1\text{V}_{\text{P-P}}$, $f=120\text{Hz}$	60	72	-	dB
Current limit	I_{LIMIT}	All	$V_I = V_O+2\text{V}$	1.1	1.8	-	A
Thermal Shutdown	T_{TSD}	All	$V_I = V_O+1.5\text{V}$ $I_O = 0 \text{ to } 10\text{mA}$	-	160	-	$^\circ\text{C}$
Thermal shutdown hysteresis	T_{HYS}	All	$V_I = V_O+1.5\text{V}$ $I_O = 0 \text{ to } 10\text{mA}$	-	10	-	$^\circ\text{C}$

Note 4: Low duty pulse testing with Kelvin connections required.

◆ Electrical Characteristic Curves

Fig.3 V_{OUT} vs T_A

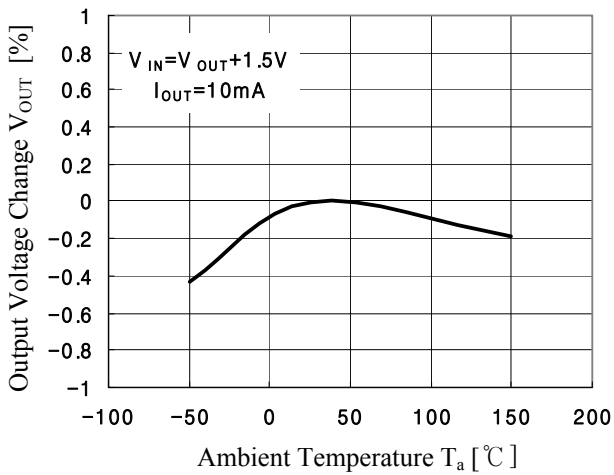

Fig.4 I_{OUT} vs $V_{IN} - V_{OUT}$

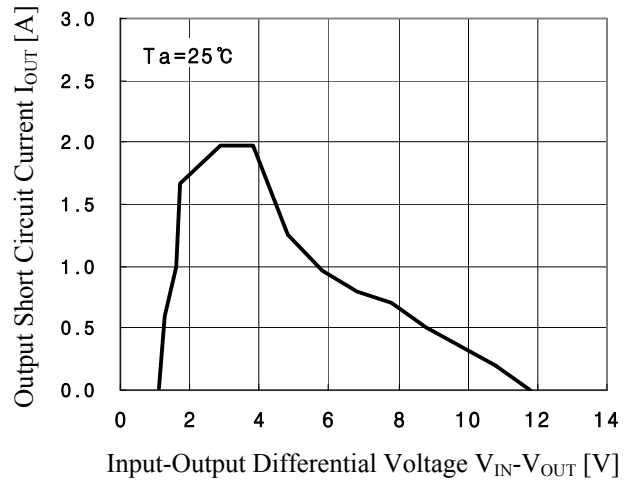

Fig.5 I_{OUT} vs T_A

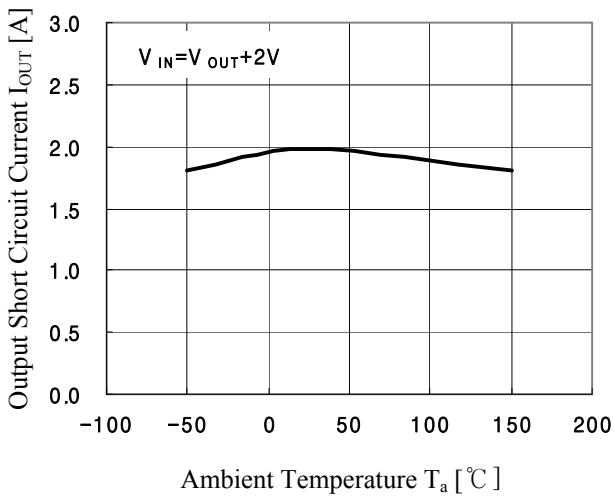

Fig.6 I_{Adj} vs T_A

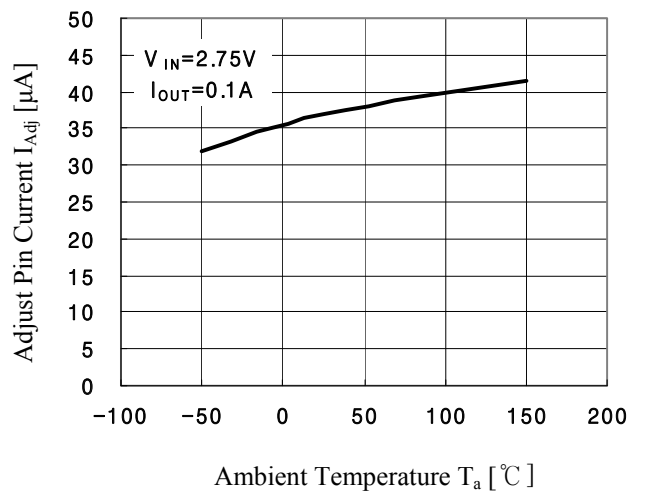

Fig.7 I_Q vs T_A

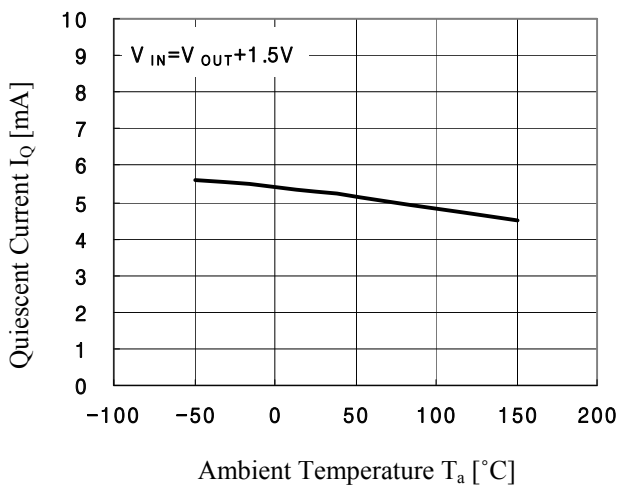
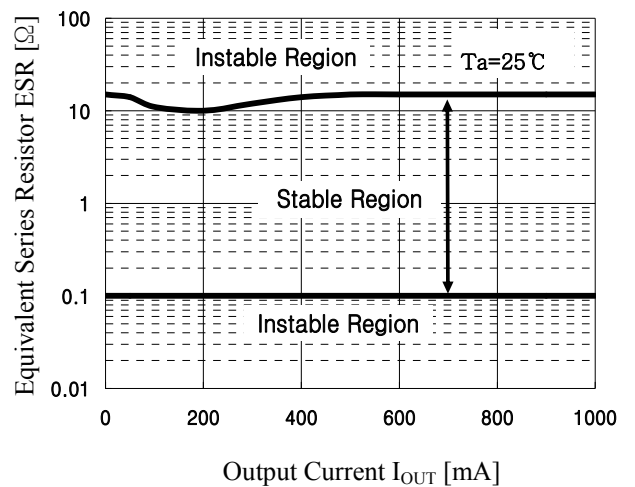

Fig.8 ESR vs I_{OUT}



◆ Electrical Characteristic Curves

Fig.9 SJ1117-285

Line Transient Response

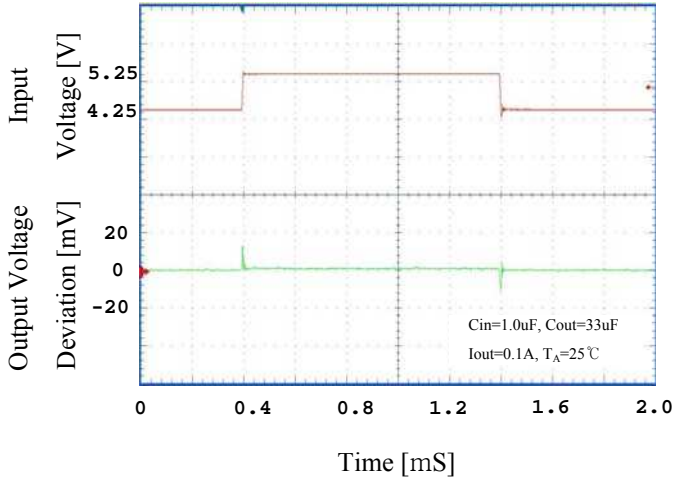

Fig.10 SJ1117-50

Line Transient Response

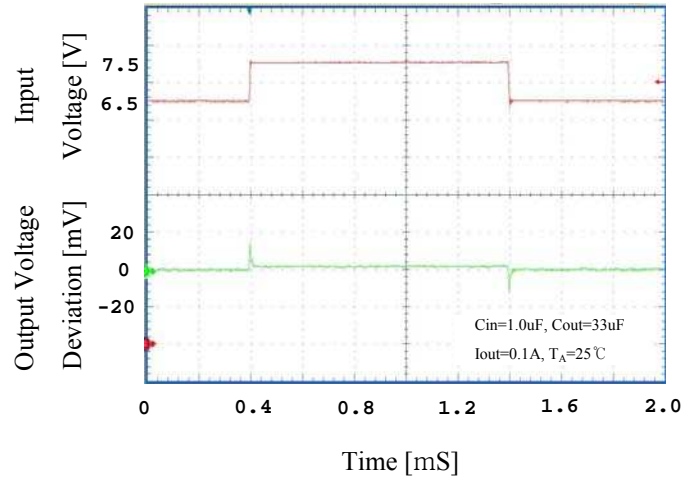

Fig.11 SJ1117-285

Load Transient Response

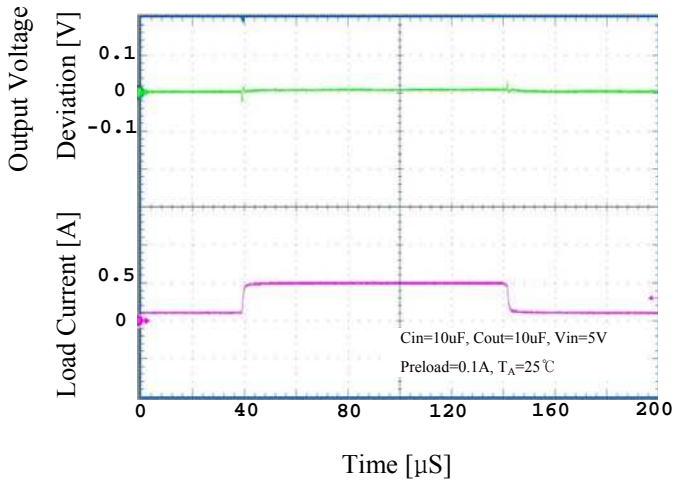
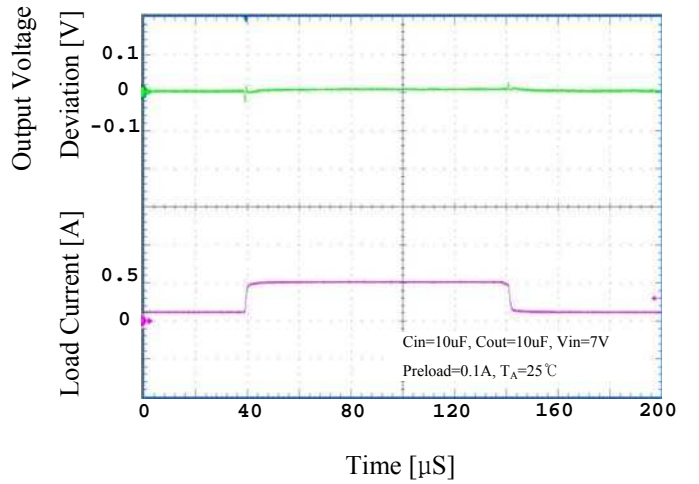

Fig.12 SJ1117-50

Load Transient Response



◆ **Application Note**

Input Bypass Capacitor (C_{IN})

An Input capacitor is recommended. A 10μF tantalum capacitor on the input is a suitable bypassing for all applications.

Adjust Terminal Bypass Capacitor(C_{ADJ})

The adjust terminal can be bypassed to ground with a bypass capacitor to improve ripple rejection. This bypass capacitor prevents ripple from being amplified as the output voltage is increased. At any ripple frequency, the impedance of the C_{ADJ} should be less than R1 to prevent the ripple from being amplified

$$\frac{1}{(2\pi \times f_{RIPPLE} \times C_{ADJ})} < R1$$

The R1 is the resistor between the output and the adjust pin.

Output Capacitor(C_{OUT})

The output capacitor(C_{OUT}) is critical in maintaining regulator stability, and must meet required conditions for both minimum amount of capacitance and ESR. The minimum C_{OUT} required is 10μF(tantalum capacitor). Any increase of the C_{OUT} will merely improve the stability and transient response. The ESR of the C_{OUT} should range between 0.3Ω - 22Ω. In the case of the adjustable regulator, when the C_{ADJ} is used, a larger C_{OUT} (22μF) is required.

Output Voltage

The SJ1117 develops a 1.25V reference voltage between the output and the adjust terminal (See Fig.9). By placing a resistor between these two terminals, a constant current is caused to flow through R1 and down through R2 to set the overall output voltage. Normally this current is chosen to be the specified minimum load current. Because I_{ADJ} is very small and constant when compared to the current through R1, it represents a small error and can usually be ignored. For fixed voltage devices R1 and R2 are included in the device.

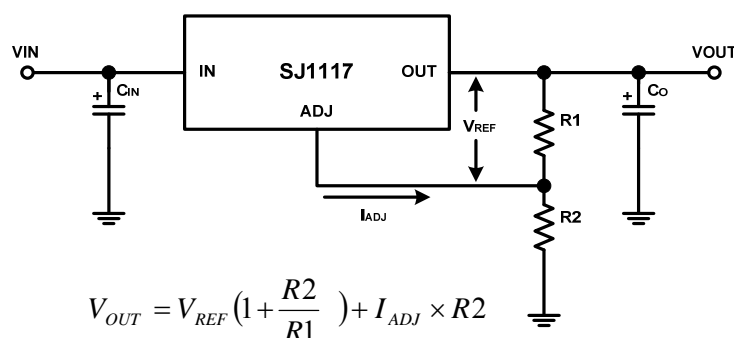

Fig.13 Basic Adjustable Regulator

◆ Application Note

Load Regulation

Load regulation will be limited by the resistance of the wire connecting the regulator to the load. The specification for load regulation is measured at the output pin of the device. Negative side sensing is a true Kelvin connection, with the bottom of the output divider returned to the negative side of the load. Although it may not be immediately obvious, best load regulation is obtained when the top of the resistor divider (R1) is returned directly to the output pin of the device(See Fig.10).

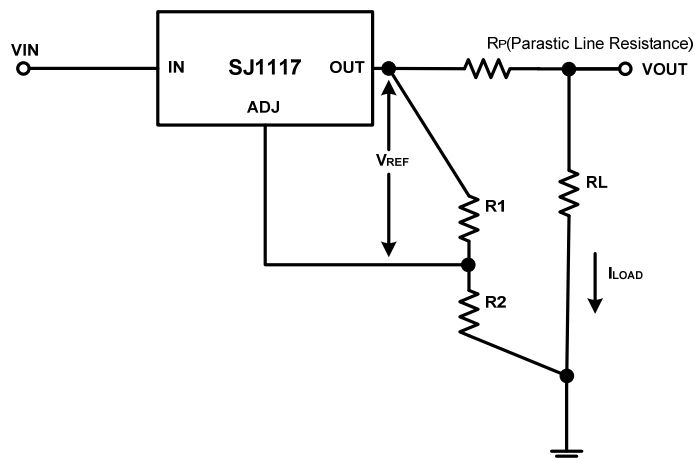

Fig.14 Connections for Best Load Regulation

For example, a 5V regulator with 0.05Ω resistance(Rp) between the regulator and load will have a load regulation due to line resistance of (Rp x IL). If R1 is connected near the load, the effective line resistance will be Rp (1+R2/R1) or in this case, it is 4 times worse. In addition, the ground side of the resistor R2 can be returned near the ground of the load to provide remote ground sensing and improve load regulation.

Protection Diodes

Diodes between input and output are not usually needed. The internal diode between the output and input pins of the device can withstand microsecond surge currents of 10A to 20A. Normal power supply cycling can not generate currents of this magnitude. Only with extremely large output capacitors, such as 1000μF and larger, and with the input pin instantaneously shorted to ground can damage occur. A crowbar circuit at the input of the SJ1117 in combination with a large output capacitor could generate currents large enough to cause damage. In this case a diode from output to input is recommended, as shown in Figure 11.

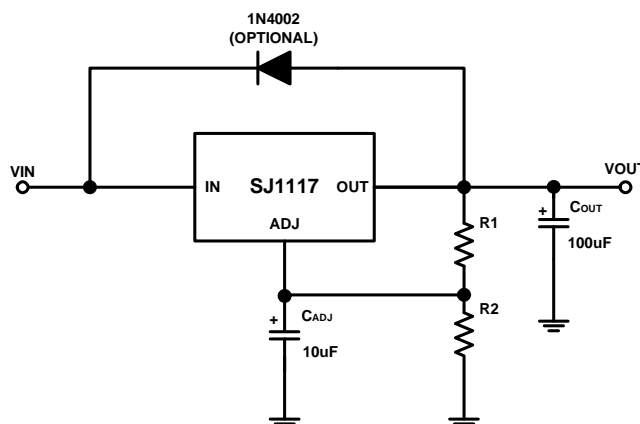

Fig.15 Protection Diodes

◆ Application Note**Thermal Considerations**

SJ1117 series regulator have internal thermal limiting circuitry designed to protect the device during overload conditions. For continuous normal load conditions however, the maximum junction temperature rating of 125°C must not be exceeded.

The thermal resistance for each application will be affected by thermal interactions with other components on the board. Some experimentation will be necessary to determine the actual value.

Calculation

Power Dissipation : $P_D = (V_{IN} - V_{OUT}) \times (I_{OUT})$

Maximum junction temperature : $T_J = T_{A(MAX)} + P_D$

◆ Typical Application

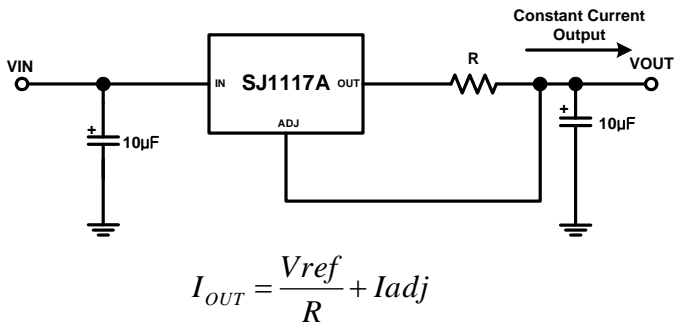

$$I_{OUT} = \frac{V_{ref}}{R} + I_{adj}$$

Fig.16 Constant Current Regulator

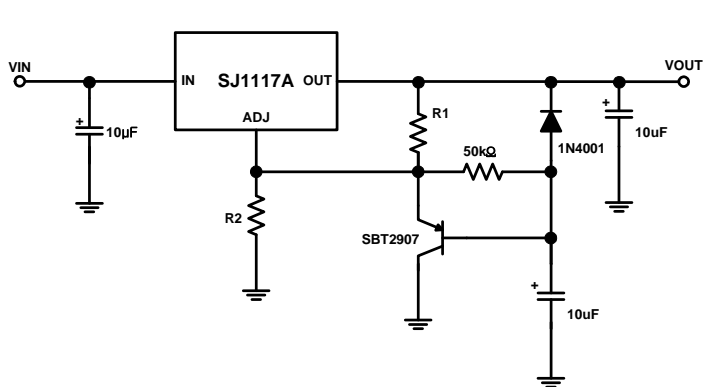
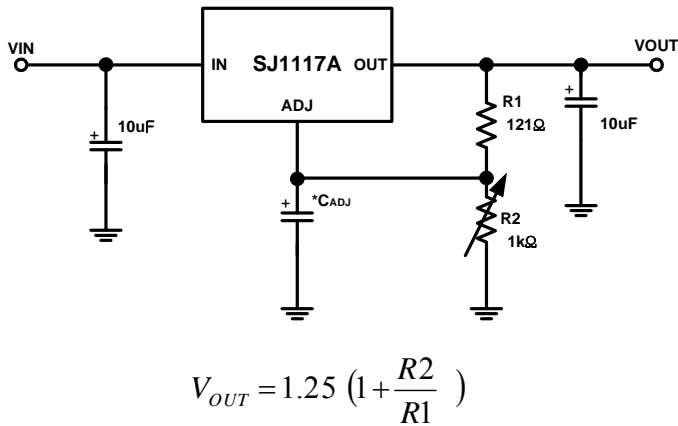

Fig.17 Slow Turn-On Regulator



$$V_{OUT} = 1.25 \left(1 + \frac{R2}{R1} \right)$$

*: C_{ADJ} is optional, but it will improve ripple rejection.

Fig.18 1.25V to 10V Adjustable Regulator with improved Ripple Rejection

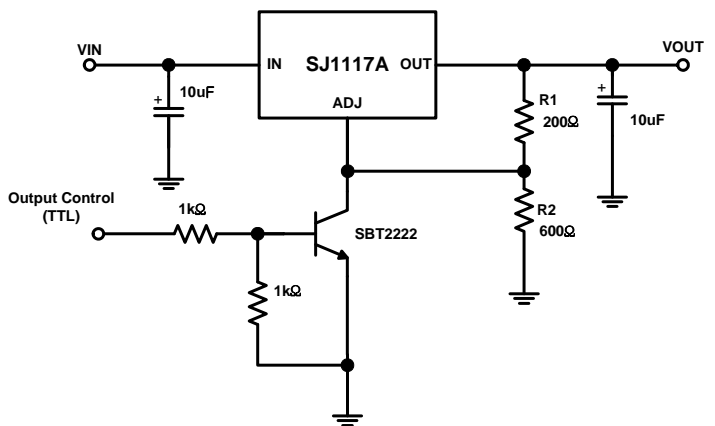

$$V_{OUT(OFF)} = V_{ref}$$

Fig.19 5V Logic Regulator with Electronic Shutdown

◆ Typical Application

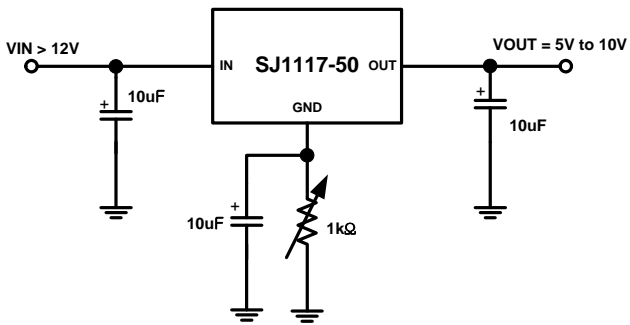

Fig.20 Adjusting Output of Fixed Regulators

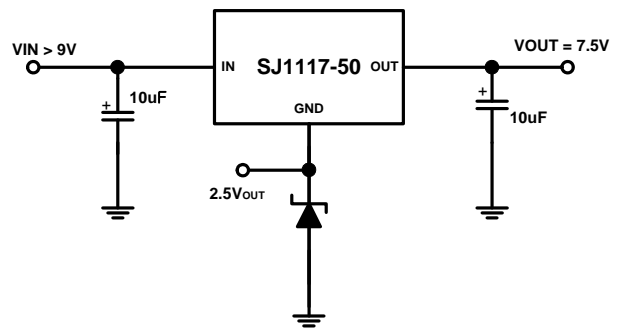
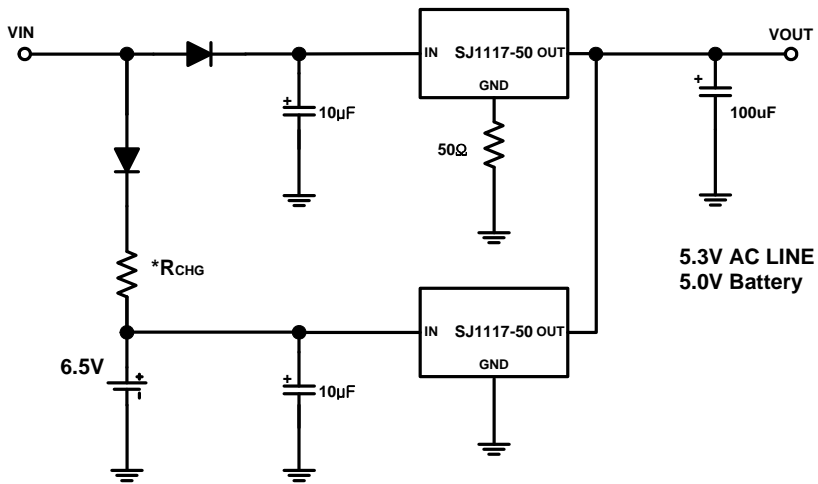

Fig.21 Regulators with Reference



*: R_{CHG} : Select for charge rate.

Fig.22 Battery Backed-up Power Supply

◆ SOT-89 Outline Dimension (unit : mm)

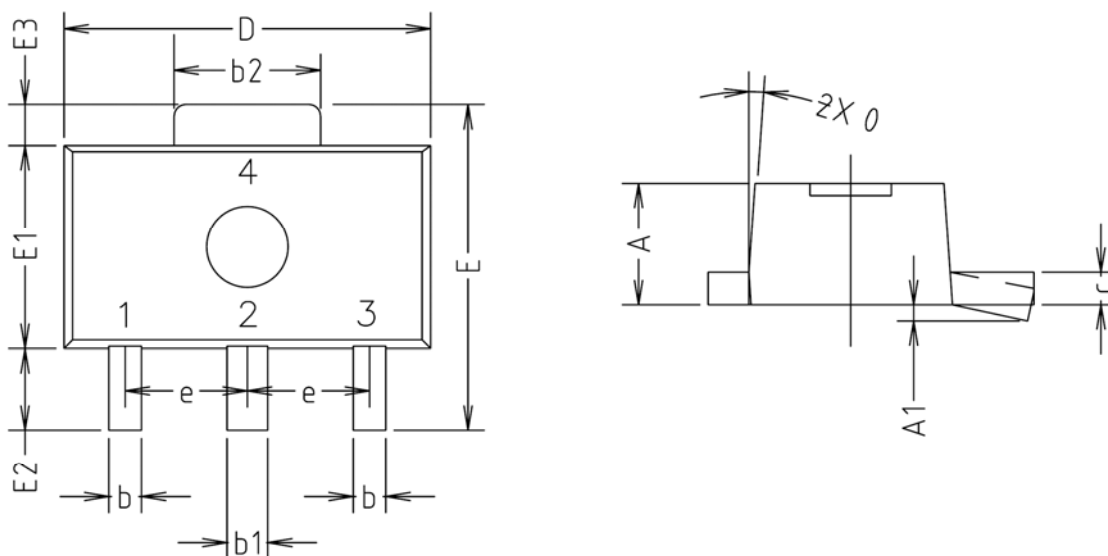

SYMBOL	MILLIMETERS			NOTE
	MINIMUM	NOMINAL	MAXIMUM	
A	1.40	1.50	1.60	
A1	0.00	—	0.10	
b	0.38	0.42	0.48	
b1	0.48	0.52	0.58	
b2	1.79	1.82	1.87	
c	0.40	0.42	0.46	
D	4.40	4.50	4.70	
E	3.70	4.00	4.30	
E1	2.40	2.50	2.70	
E2	0.80	1.00	1.20	
E3	0.40	0.50	0.60	
e	1.50 TYP.			
θ	4° TYP.			

※ Recommend PCB solder land [Unit: mm]

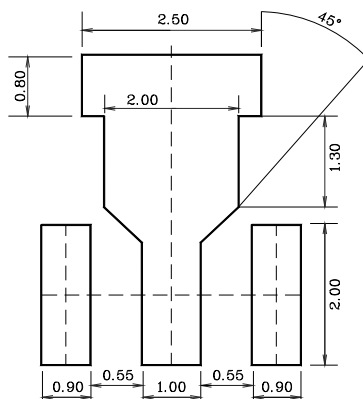

◆ SOT-223 Outline Dimension (unit : mm)

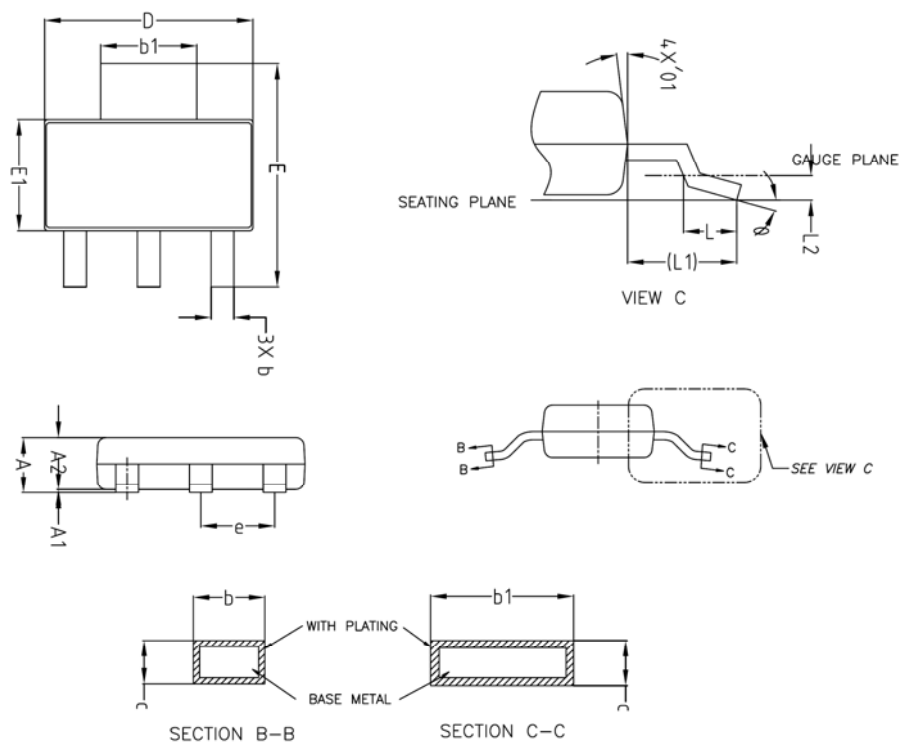

SYMBOL	MILLIMETERS			NOTE
	MINIMUM	NOMINAL	MAXIMUM	
A	—	—	1.80	
A1	0.00	—	0.10	
A2	1.60	1.65	1.70	
b	0.68	—	0.76	
b1	2.95	—	3.07	
c	0.23	—	0.28	
D	6.40	6.50	6.60	
E	6.80	7.00	7.20	
E1	3.40	3.50	3.60	
e	2.30 BSC			
L	0.45	—	0.65	
L1	1.75 REF			
L2	0.10 BSC			
ϕ	0°	—	10°	
$\phi1$	5°	—	10°	

※ Recommend PCB solder land [Unit: mm]

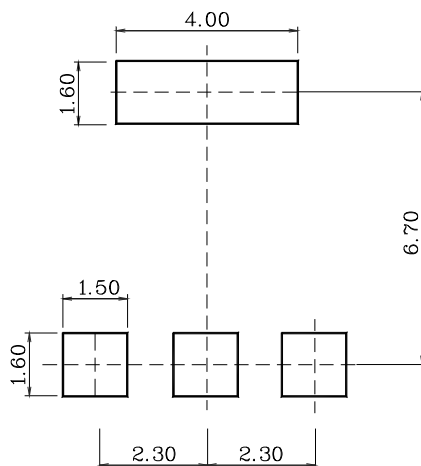

◆ TO-252 Outline Dimension (unit : mm)

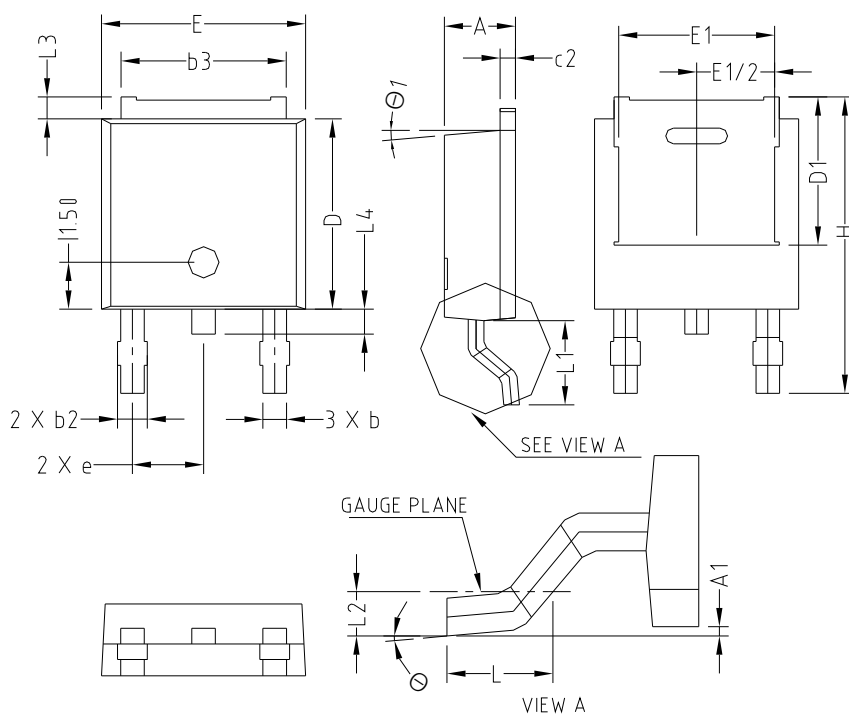

SYMBOL	MILLIMETERS			NOTE
	MINIMUM	NOMINAL	MAXIMUM	
A	2.20	2.30	2.40	
A1	0.00		0.127	
b	0.66	0.76	0.86	
b2	-	-	0.96	
b3	5.04	5.34	5.64	
c2	0.40	0.50	0.60	
D	5.90	6.10	6.30	
D1	4.75			
E	6.40	6.60	6.80	
E1	5.04			
e	2.30 BSC			
H	9.20	9.50	9.80	
L	1.27	1.47	1.67	
L1	2.50	2.70	2.90	
L2	0.508 BSC			
L3	0.50	0.70	0.90	
L4	0.60	0.80	1.00	
Θ	0°	-	10°	
$\Theta1$	5°			

※ Recommend PCB solder land [Unit: mm]

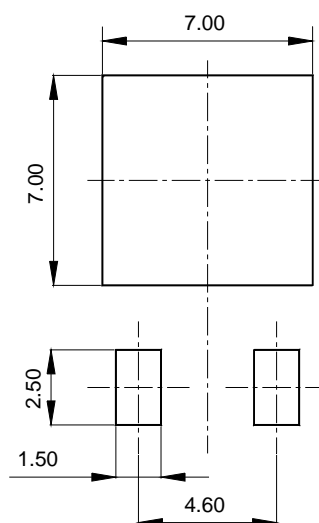

◆ TO-220F-3L Outline Dimension (unit : mm)

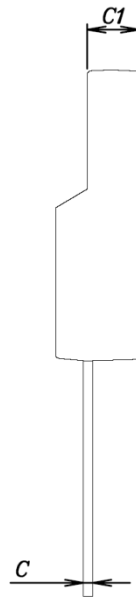
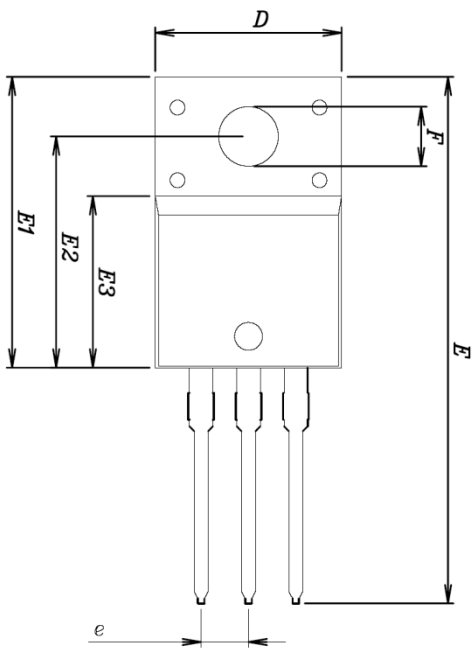

SYMBOL	MILLIMETERS			NOTE
	MINIMUM	NOMINAL	MAXIMUM	
A	—	—	4.60	
A1	2.45	2.50	2.55	
A2	1.95	2.00	2.05	
b	0.65	0.75	0.85	
b1	1.07	1.27	1.47	
C	0.40	0.50	0.60	
C1	2.70	2.80	2.90	
D	9.90	10.00	10.10	
E	28.00	—	28.60	
E1	15.50	15.60	15.70	
E2	12.30	12.40	12.50	
E3	9.15	9.20	9.25	
F	3.10	3.20	3.30	
G	3.30	3.40	3.50	
e	2.54 BSC			
L	12.40	—	13.00	
L1	3.46 BSC			

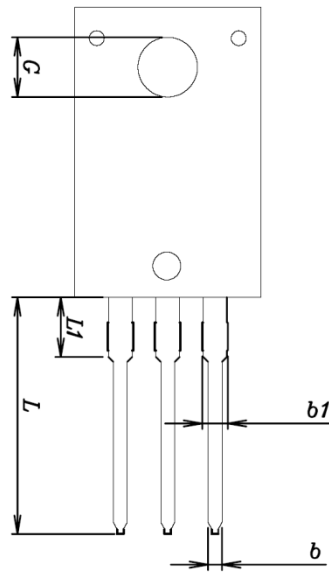
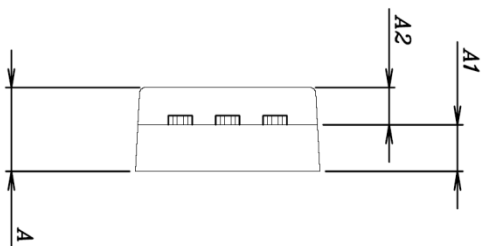

The AUK Corp. products are intended for the use as components in general electronic equipment (Office and communication equipment, measuring equipment, home appliance, etc.).

Please make sure that you consult with us before you use these AUK Corp. products in equipments which require high quality and / or reliability, and in equipments which could have major impact to the welfare of human life(atomic energy control, airplane, spaceship, transportation, combustion control, all types of safety device, etc.). AUK Corp. cannot accept liability to any damage which may occur in case these AUK Corp. products were used in the mentioned equipments without prior consultation with AUK Corp..

Specifications mentioned in this publication are subject to change without notice.